



City of Doral

8401 NW 53rd Ter. Doral, FL 33166
(305) 593-6725

National Pollution Discharge Elimination System (NPDES) **Construction Site Erosion and Sedimentation Control**

Introduction: The City of Doral participates as a co-permittee with Miami-Dade County in the National Pollution Discharge Elimination System (NPDES) program. The program is aimed at improving stormwater runoff water quality. The City of Doral must address specified activities and program compliance stated within the Annual Reports and permit conditions. The permit conditions require the Building Department, Planning & Zoning Department, Public Works Department, and Code Compliance Department to enforce the following activities as part of the Construction Site Erosion and Sedimentation Control (construction activity means the act of developing or improving land that involves the disturbance of soils and includes clearing, grading, and excavation. FDEP has determined that demolition activities also meet the definition of construction activity):

1. **Submission of Erosion & Sedimentation Control plan:** Applicants for new construction projects or substantial improvements (i.e., additions, pools, etc.) shall submit as part of the mandatory permit submittal documents of an erosion and sedimentation control plan for the development of the site. The qualifier for the permittee shall attest by his notarized signature that the erosion and sedimentation control plan will be maintained for the duration of the permitted construction activities (see below).
2. **Best Management Practices (BMPs) for Erosion and Sedimentation Control:** Three (3) mandatory erosion and sedimentation control best management practices shall always be implemented at each development site. These are:
 - a. **Temporary Gravel Construction Entrance & Exit** (See Attachment A).
 - b. **Storm Drain Inlet Protection** (See Attachment B).
 - c. **Staked Turbidity Barrier (Silt Fence)** (See Attachment C).

NOTE: The Preceding three elements of the plan must be implemented at the development site, inspected and approved by the Chief Building Official or designated inspector prior to the acceptance of the first mandatory Florida Building Code inspection request.

3. **Compliance with Erosion and Sedimentation Control Plan:** Mandatory Florida Building Code inspections and inspection for erosion and sedimentation control shall be performed simultaneously with construction inspections. Failure to maintain erosion and sedimentation control measures during the entire construction phase will result in a rejected inspection request and/or Code Compliance Department action to be treated as a violation of the City's Code or Ordinance by the Code Compliance Officer.
4. **Other applicable Environmental Permits:** The Contractor is responsible to obtain any applicable environmental permits which includes and is not limited to the [SFWMD ERP](#), [FDEP CGP](#), or [MDC DERM](#). Contractor is to review the eligibility of their construction activities and obtain all applicable permits as required under each permit condition.



City of Doral

8401 NW 53rd Ter. Doral, FL 33166
(305) 593-6725

I hereby agree to maintain the attached erosion and sedimentation control plan for the duration of the construction phase.

General Contractor - Company Name

Notary

Name of Qualifier

License Number of Qualifier

Signature of Qualifier

____ Day of _____ 20____

Attachment A: Stabilized Construction Entrance & Exit

Temporary Gravel Construction Entrance & Exit

Definition:

A stone stabilized pad located at points of vehicular ingress and egress on a construction site.

Purpose:

To stabilize entrances to the construction site and reduce the amount of sediment transported onto public roads by motor vehicles or runoff.

Planning Considerations:

Construction entrances provide an area where mud can be removed from construction vehicle tires before they enter a public road. If the action of the vehicle traveling over the stabilized pad is not sufficient to remove most of the mud, then the tires must be washed before the vehicle enters a public road. If tire washing is provided, provision must be made to intercept the wash water and trap the sediment before it is carried offsite. Construction entrances should be used in conjunction with the stabilization of construction roads to reduce the amount of mud picked up by construction vehicles.

Design Criteria:

Aggregate Size

FDOT No. 1 Coarse Aggregate (1.5 – 3.5 inch stone) (4 – 9 cm) should be used. Wood chips may be used for single family residential construction, provided that they can be prevented from floating away in a storm. Manufactured products also are available to prevent or reduce the amount of sediment tracked onto roadways. If a stabilized exit is not sufficient, street sweeping can be provided as an additional measure.

Entrance Dimensions

If stoned is used, the aggregate layer must be at least 6 inches (15 cm) thick. It must extend the **full width** of the vehicular ingress and egress area. The length of the entrance must be at least 50 feet (20 m). The entrance should widen at its connection to the roadway to accommodate the turning radius of large trucks. (See Figure 1 – Temporary Gravel Construction Entrance)

Construction Specifications

The entrance area should be cleared of all vegetation, roots, and other objectionable material. A geotextile should be laid down to improve stability and simplify maintenance when gravel is used. The gravel shall then be placed over the geotextile to the specified dimensions.

Maintenance:

The stabilized construction exit shall be maintained in a condition that will prevent the tracking or flow of mud onto public rights-of-way. This may require periodic maintenance as conditions demand, and the repair and/or cleanout of any structures used to trap sediments. All materials spilled, dropped, washed, or tracked from vehicles onto roadways or into storm drains must be removed immediately. Sweep the paved road as needed.

Figure 1 – Temporary Gravel Construction Entrance

CHAPTER 4: BEST MANAGEMENT PRACTICES FOR EROSION AND SEDIMENTATION CONTROL

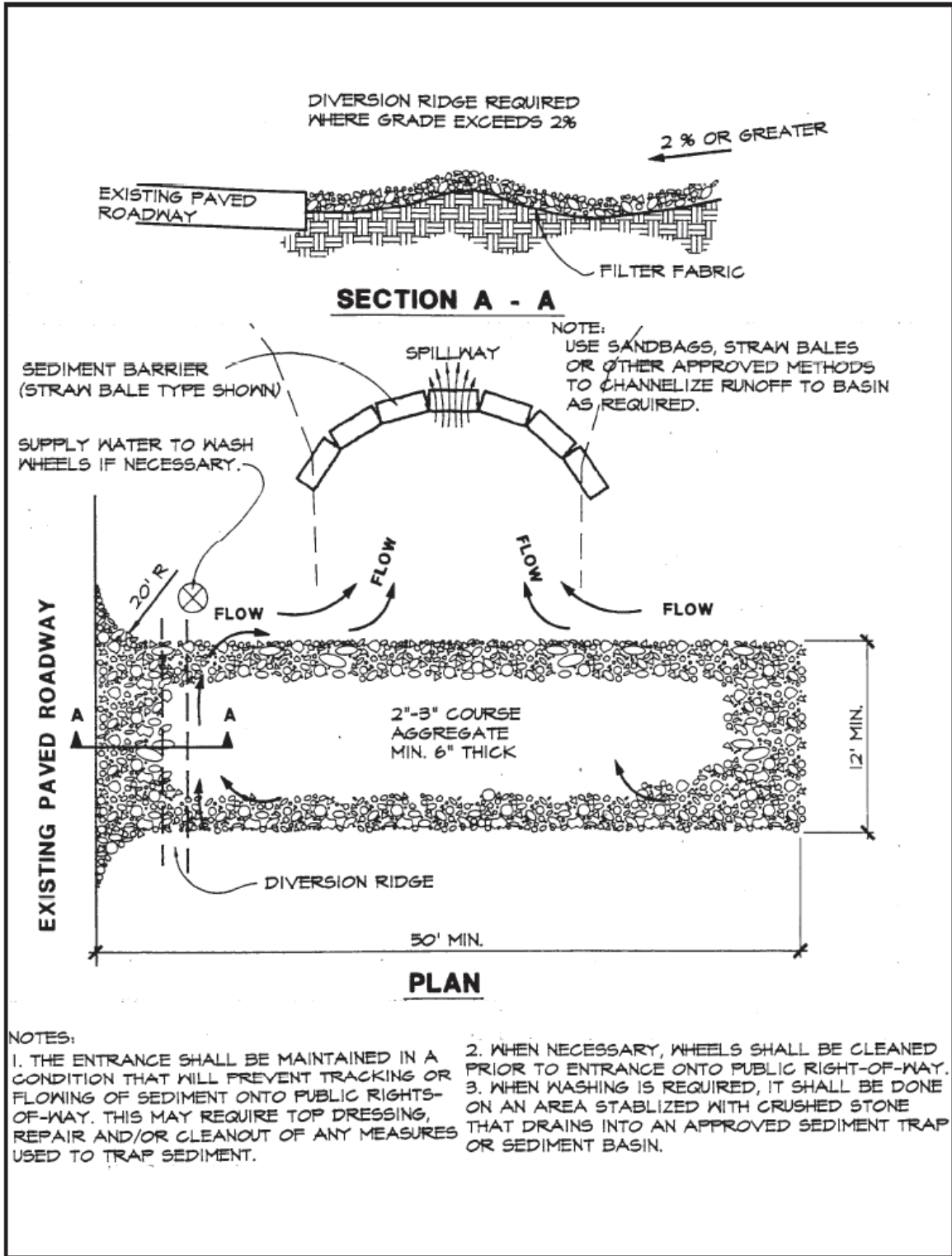

Figure 4.3a. Temporary Gravel Construction Entrance

Source: Erosion Draw

Attachment B: Storm Drain Inlet Protection

Storm Drain Inlet Protection

Definition:

A sediment filter or an excavated impounding area around a storm drain drop inlet or curb inlet.

Purpose:

The purpose of a storm drain inlet is to prevent sediment from entering stormwater conveyance systems prior to permanent stabilization of the disturbed area.

Condition Where Practice Applies:

Practice applies where storm drain inlets are to be made operational before permanent stabilization of the disturbed drainage area. Different types of structures are applicable to different conditions (See Figures 2 through 12).

Planning Considerations:

Storm sewers that are made operational before their drainage area is stabilized can convey large amounts of sediment to receiving waters. In the case of extreme sediment loading, the storm sewer itself may clog and lose most of its capacity. To avoid these problems, it is necessary to prevent sediment from entering the system at the inlets.

There are several types of inlets filters and traps, which have different applications depending on the site conditions and type of inlet. Other innovative techniques for accomplishing the same purpose are encouraged, but only after specific plans and details are submitted to and approved by the stormwater permitting agency.

Note that these various inlet protection devices are for drainage areas **less than 1 acre (0.4 ha)**. Runoff from large, disturbed areas should be routed through a Temporary Sediment Trap.

Design Criteria:

1. The drainage area shall be no greater than 1 acre (0.4 ha).
2. The inlet protection device shall be constructed to facilitate the cleanout and disposal of trapped sediment and to minimize interference with construction activities.
3. The inlet protection device shall be constructed so that any resultant ponding or stormwater will not cause excessive inconvenience or damage to adjacent areas or structures.
4. Figures 2 through 12 provide specific design criteria for each particular inlet protection device.

Figure 2 - Gravel and Wire Mesh Drop Inlet Sediment Filter

CHAPTER 4: BEST MANAGEMENT PRACTICES FOR EROSION AND SEDIMENTATION CONTROL

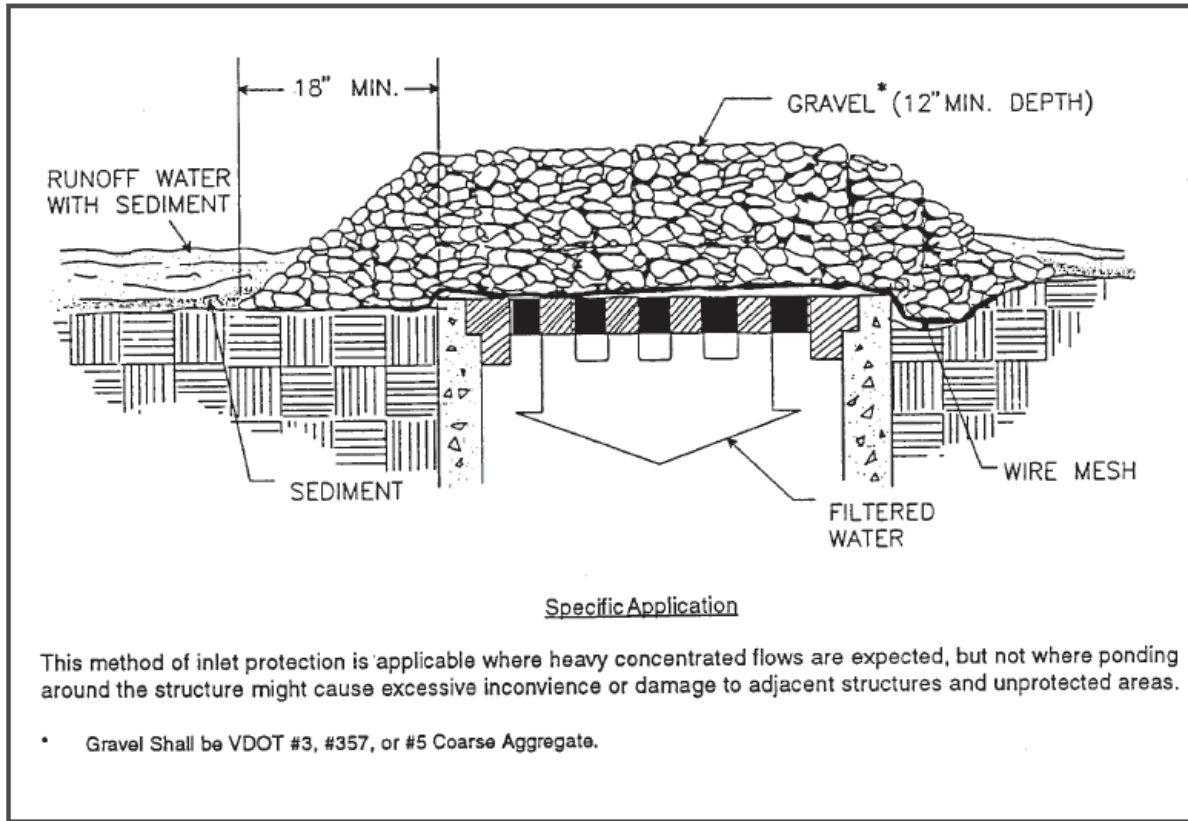

Figure 4.5c. Gravel and Wire Mesh Drop Inlet Sediment Filter

Source: Virginia DSWC

Figure 3 - Gravel Filters for Area Inlets

CHAPTER 4: BEST MANAGEMENT PRACTICES FOR EROSION AND SEDIMENTATION CONTROL

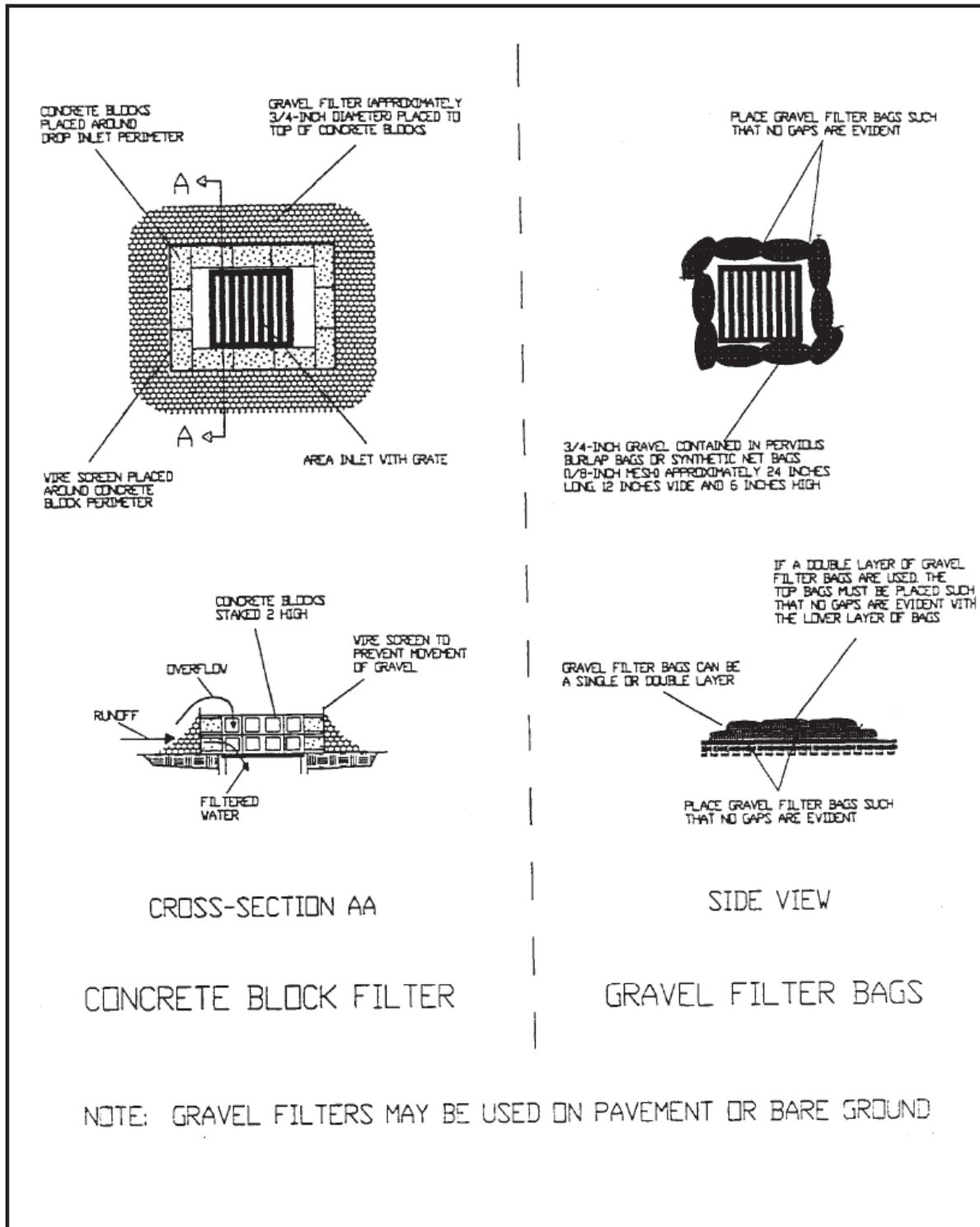

Figure 4.5e. Gravel Filters for Area Inlets

Source: HydroDynamics, Inc.

Figure 4 - Block and Gravel Curb Inlet Sediment Barrier

CHAPTER 4: BEST MANAGEMENT PRACTICES FOR EROSION AND SEDIMENTATION CONTROL

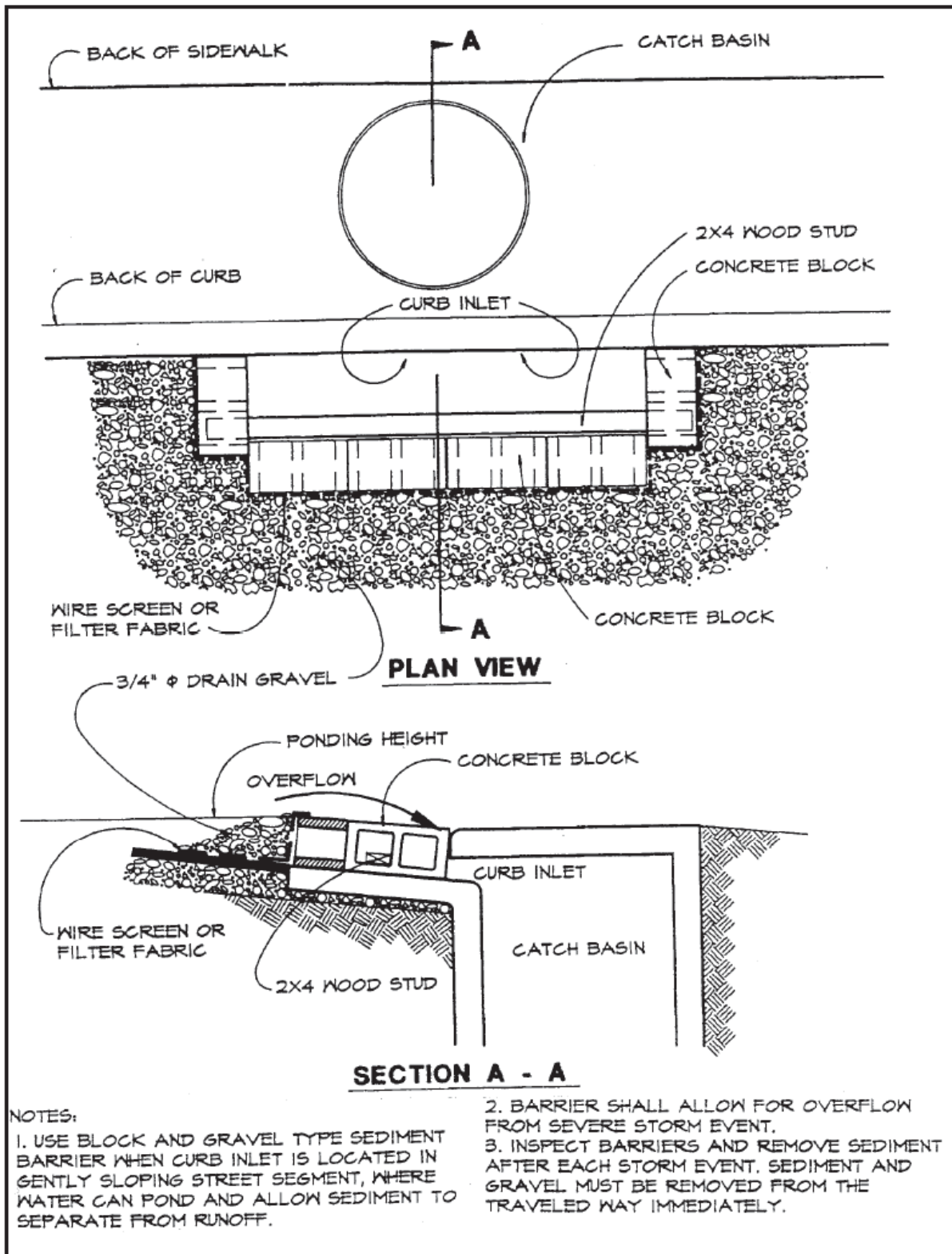

Figure 4.5i. Block and Gravel Curb Inlet Sediment Barrier

Source: Erosion Draw

Figure 5 - Curb Inlet Gravel Filters

CHAPTER 4: BEST MANAGEMENT PRACTICES FOR EROSION AND SEDIMENTATION CONTROL

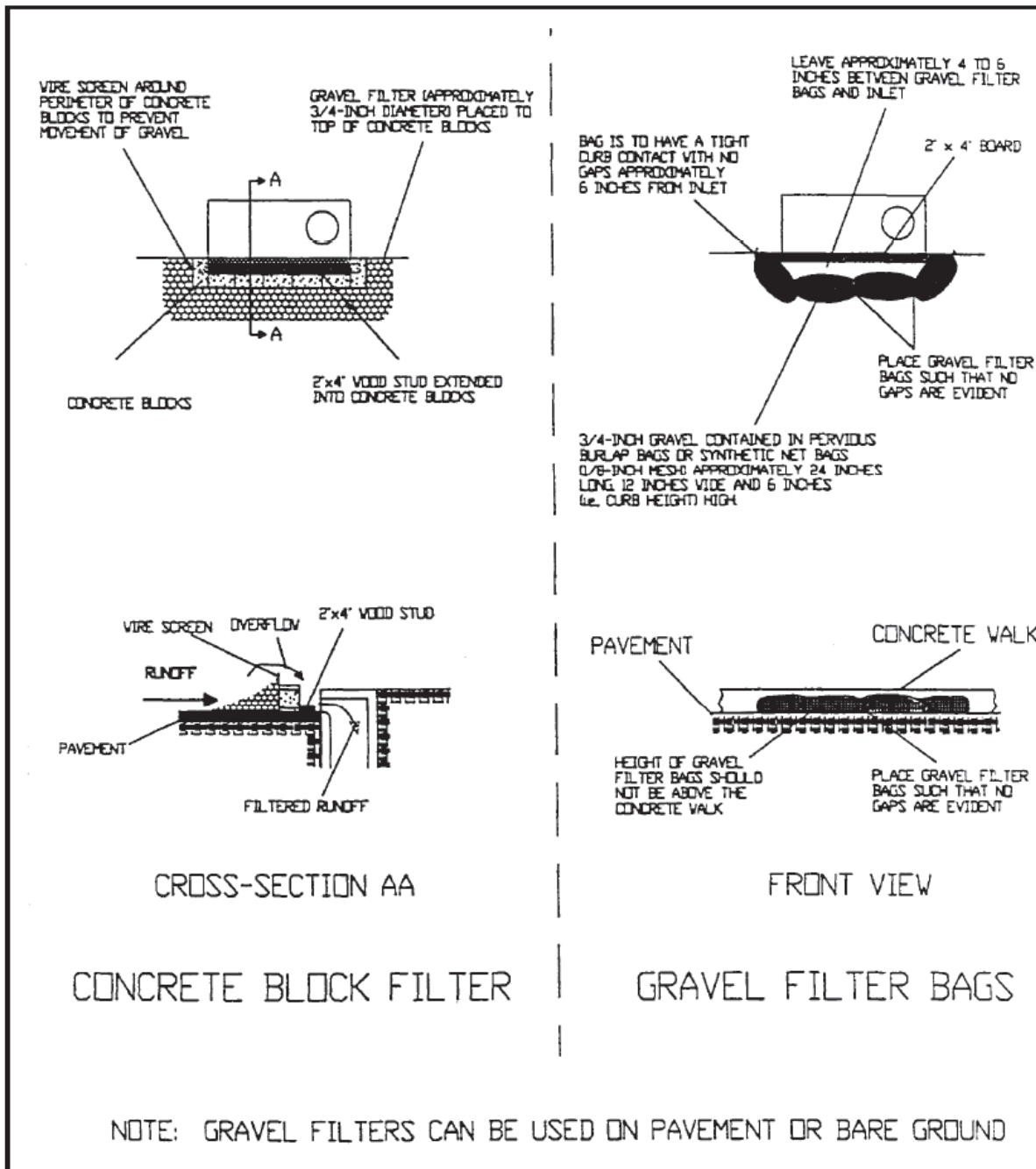

Figure 4.5j. Curb Inlet Gravel Filters

Source: HydroDynamics, Inc.

Figure 6 - Curb Inlet Sediment Barrier

CHAPTER 4: BEST MANAGEMENT PRACTICES FOR EROSION AND SEDIMENTATION CONTROL

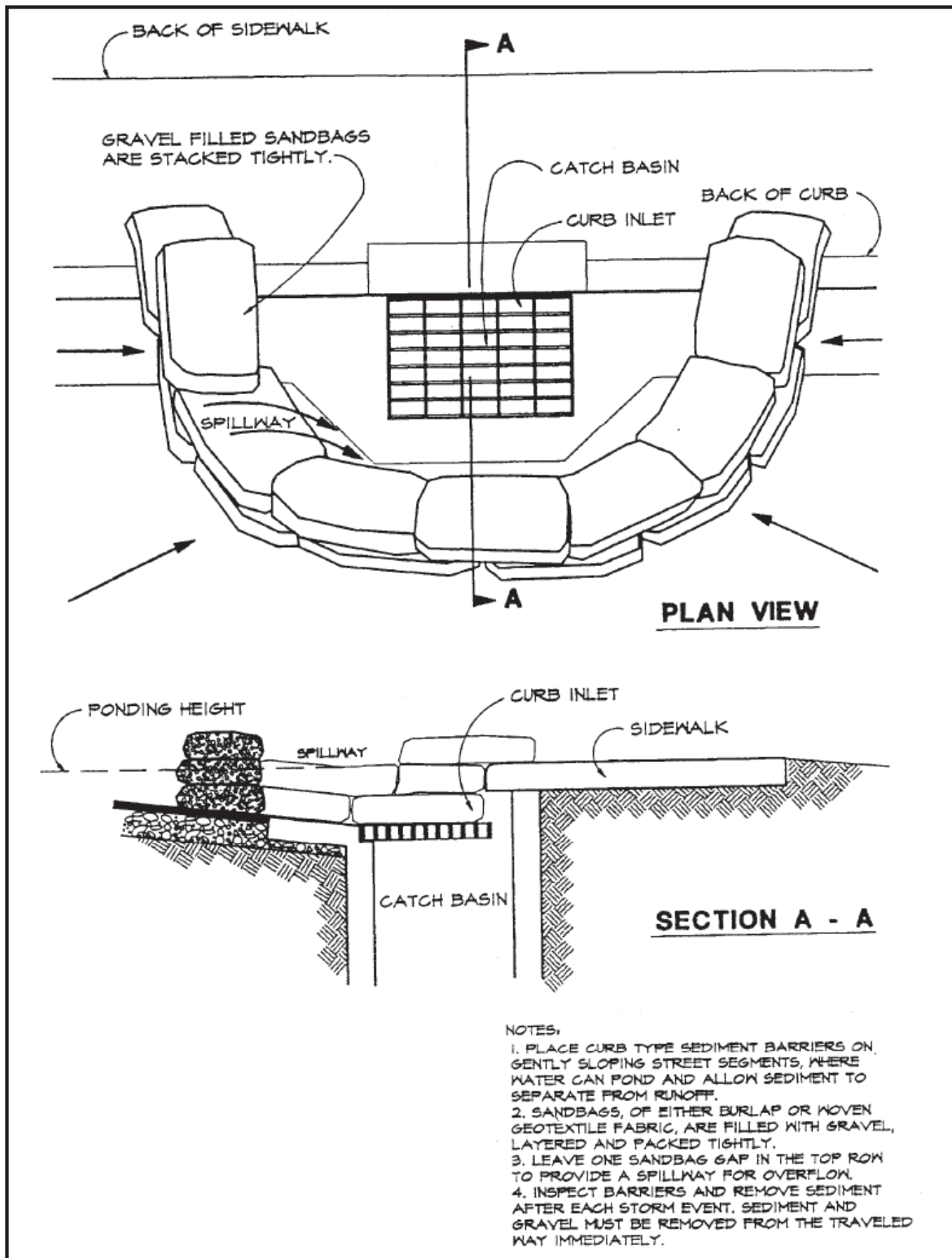

Figure 4.5k. Curb Inlet Sediment Barrier

Source: Erosion Draw

Attachment C: Stacked Turbidity Barrier (Silt Fence)

Silt Fence

Definition:

A temporary sediment barrier consisting of a filter fabric stretched across and attached to supporting posts and entrenched. Some silt fence is wire reinforced for support.

Purpose:

The purpose of a silt fence is to slow the velocity of water and retain sediment on site.

Planning Considerations:

Silt fences can trap a much higher percentage of suspended sediments than straw bales and are preferable to straw barriers in many cases. The most effective application is to install two parallel silt fences spaced a minimum of three feet apart. The installation and maintenance methods outlined here can improve performance.

Design Criteria:

1. No formal design is required for many small projects and minor incidental applications.
2. Silt fences shall have an expected usable life of six months. They are applicable around perimeters and stock piles, and at temporary locations where continuous construction changes the earth contour and runoff characteristics.
3. Silt fences have limited applicability to situations in which only sheet or overland flows are expected. They normally cannot filter the volumes of water generated by channel flows, and many fabrics do not have sufficient structural strength to support the weight of water ponded behind the fence line.

Construction Specifications:

Materials

1. Synthetic filter fabric shall be pervious sheet of propylene, nylon, polyester, or polyethylene yarn. It shall contain ultraviolet ray inhibitors and stabilizers to provide a minimum of 6 months of expected usable construction life at a temperature range of 0°F to 120°F (-17°C to 49°C).
2. The stakes for a silt fence shall be 1 x 2 inches (2.5 x 5 cm) wood (preferred), or equivalent metal with a minimum length of 3 feet (90 cm).
3. Wire fence reinforcement for silt fences using standard-strength filter cloth shall be a minimum of 36 inches (90 cm) in height, shall be a minimum 14 gauge, and shall have a maximum mesh spacing of 6 inches (15 cm).

Sheetflow Application: Silt Fence

1. The height of a silt fence shall not exceed 36 inches (90 cm). Higher fences may impound volumes of water sufficient to cause failure of the structure.
2. The filter fabric shall be purchased in a continuous roll cut to the length of the barrier to avoid the use of joints. When joints are necessary, filter cloth shall be spliced as described in Item 8 below.
3. Posts shall be spaced a maximum of 10 feet (3 m) apart at the barrier location and driven securely into the ground a minimum of 12 inches (30 cm). When extra-strength fabric is used without the wire support fence, post spacing shall not exceed 6 feet (1.8 m).
4. A trench shall be excavated approximately **4 inches (10 cm) wide and 4 inches (10 cm) deep** along the line of posts and upslope from the barrier.
5. When standard-strength filter fabric is used, a wire mesh support fence shall be fastened securely to the upslope side of the posts using heavy duty wire staples at least 1 inch (25 mm) long, tie wires, or hog rings. The wire shall extend into the trench a minimum of 2 inches (5 cm) and shall not extend more than 36 inches (90 cm) above the original ground surface.

6. The standard-strength filter fabric shall be stapled or wired to the fence and 8 inches (20 cm) of the fabric shall be extended into the trench. The fabric shall not extend more than 36 inches (90 cm) above the original ground surface.
7. When extra-strength filter fabric and closer post spacing are used, the wire mesh support fence may be eliminated. In this case, the filter fabric is stapled or wired directly to the posts with all other provisions of Item 6 applying.
8. When attaching 2 silt fences together, place the end post of the second fence inside the end post of the first fence. Rotate both posts at least 180 degrees in a clockwise direction to create a tight seal with the filter fabric. Drive both posts into the ground and bury the flap (See Figure 14 – Silt Fence Installation)
9. The trench shall be backfilled and the soil compacted over the filter fabric.
10. The most effective application consists of a double row of silt fences spaced a minimum of 3 feet apart, so that if the first row collapses it will not fall on the second row. Wire or synthetic mesh may be used to reinforce the first row (See Figure 15 – Double Row Stacked Silt Fence).
11. When used to control sediment from a steep slope, silt fences should be placed away from the toe of the slope for increased holding capacity (See Figure 16 – Proper Placement of Silt Fence at Toe of Slope).
12. Silt fences shall be removed when they have served their useful purpose, but not before the upslope area has been permanently stabilized.

Maintenance:

1. Silt fences shall be inspected within 24 hours after each ½ inch rainfall event and at least once a week. Any required repairs shall be made immediately.
2. Should the fabric on a silt fence decompose or become ineffective before the end of the expected usable life and the barrier is still necessary, the fabric shall be replaced promptly.
3. Sediment deposits should be removed when deposits reach approximately one-half the height of the barrier.
4. Any sediment deposits remaining in place after the silt fence is no longer required shall be dressed to conform to the existing grade, prepared, and seeded.

Figure 7 - Silt Fence Detail

CHAPTER 4: BEST MANAGEMENT PRACTICES FOR EROSION AND SEDIMENTATION CONTROL

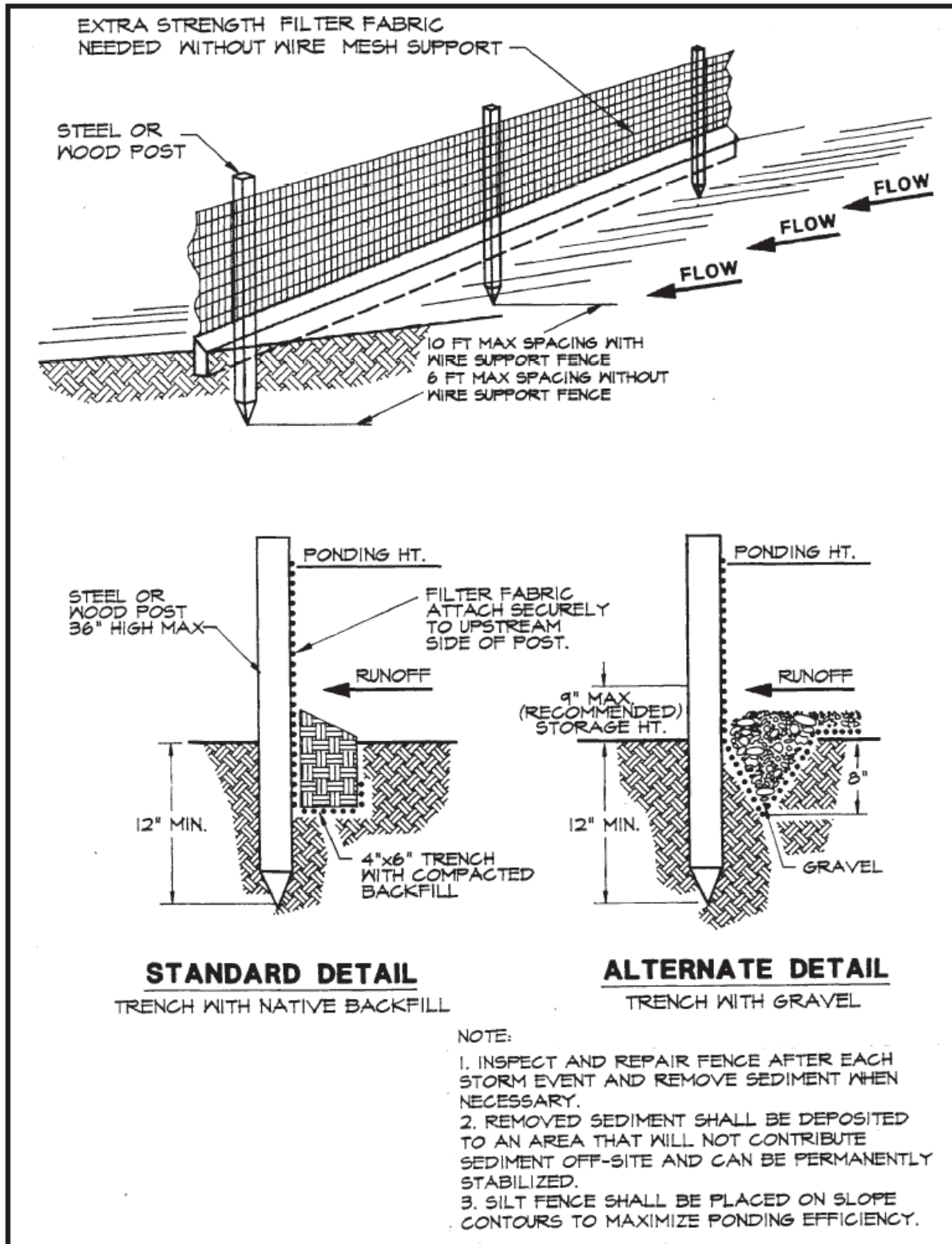

Figure 4.4a. Silt Fence

Source: Erosion Draw

CHAPTER 4: BEST MANAGEMENT PRACTICES FOR EROSION AND SEDIMENTATION CONTROL

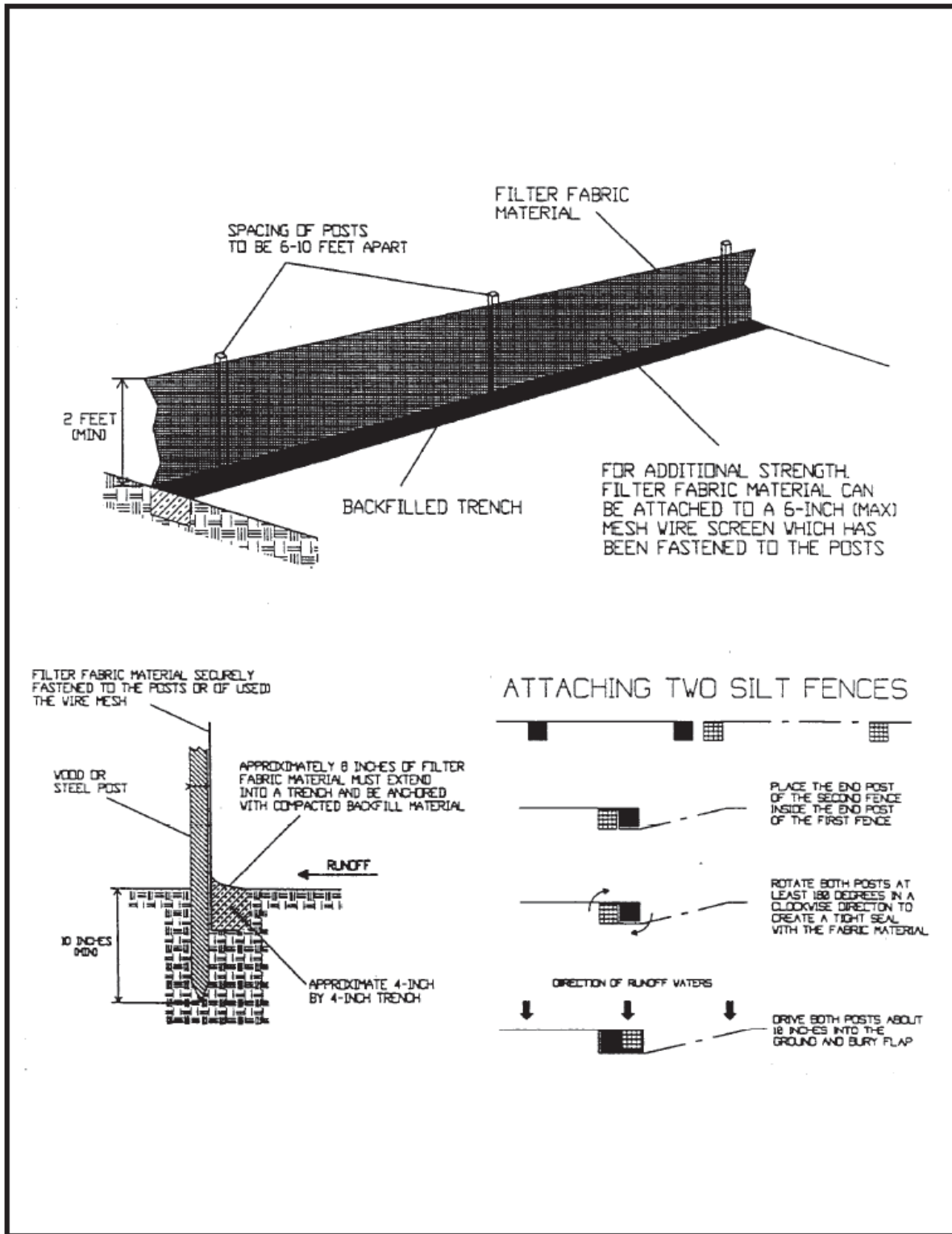

Figure 4.4b. Installing a Filter Fabric Silt Fence

Source: HydroDynamics, Inc.

References:

Florida Stormwater Erosion and Sedimentation Control Inspector's Manual
Florida Department of Environmental Protection
Nonpoint Source Management Section
Tallahassee, Florida
July 2008