

**RESOLUTION No. 20-184**

**A RESOLUTION OF THE MAYOR AND THE CITY COUNCIL OF THE CITY OF DORAL, FLORIDA, AWARDED INVITATION TO BID #2020-23, "YEAR 5A PHASE II CANAL BANK STABILIZATION PROJECT" TO ENCO, LLC., THE LOWEST, MOST RESPONSIVE AND RESPONSIBLE BIDDER; APPROVING AN AGREEMENT BETWEEN THE CITY AND ENCO, LLC. IN AN AMOUNT NOT TO EXCEED \$646,829.70 FOR YEAR 5A PHASE II CANAL BANK STABILIZATION PROJECT; AUTHORIZING THE CITY MANAGER TO NEGOTIATE AND ENTER INTO A CONSTRUCTION AGREEMENT WITH THE NEXT LOWEST BIDDER SUCCESSIVELY IF AN AGREEMENT CAN NOT BE NEGOTIATED WITH THE TOP BIDDER; AUTHORIZING THE CITY MANAGER TO EXECUTE THE AGREEMENT AND TRANSFER FUNDS IN AN AMOUNT OF \$389,100.00 FROM THE STORMWATER FUND "CONTRACTUAL SERVICES" ACCOUNT No. 401.80005.500340 TO THE STORMWATER FUND "CONSTRUCTION IN PROGRESS" ACCOUNT No. 401.80005.500650 TO BE ABLE TO CAPITALIZE THE EXPENSES ON BEHALF OF THE CITY IN FURTHERANCE HEREOF; PROVIDING FOR IMPLEMENTATION; AND PROVIDING FOR AN EFFECTIVE DATE**

**WHEREAS**, Year 5A Phase II of the Canal Bank Stabilization Program is part of the canal Capital Improvement Program (CIP) included in the Canal Feasibility Study completed in March 2008; and

**WHEREAS**, the Canal Feasibility Study documented the existing condition of the canal banks maintained by the City, identified potential needs for stabilization, recommended conceptual methods for the stabilization of canal slopes in areas that required remedial action, and summarized planning-level costs for stabilizing the canal slopes.; and

**WHEREAS**, Year 5A Phase II includes canal bank stabilization through geo-web techniques at the Dressel Canal adjacent to NW 41<sup>st</sup> Street between NW 79<sup>th</sup> Avenue and the Palmetto Expressway. Approximately 0.23 miles of stabilization will occur along the Dressel's Dairy Canal.; and

**WHEREAS**, the City issued Invitation to Bid (ITB) #2020-23, "Canal Bank

Stabilization Program Year 5A Phase II” (the “ITB”), for which the City received four (4) submittals were received and opened on July 30, 2020 with all firms meeting the required criteria; and

**WHEREAS**, upon review of bids received, staff determined that ENCO, LLC. was the lowest most responsive and responsible bidder (the “Contractor”); and

**WHEREAS**, a copy of Contractor’s Bid Submittal, which includes the “Construction Agreement”, in substantially the form provided, the ITB Inventory, and Bid Tabulation are all attached as Exhibit “A”, which is incorporated herein and made a part hereof by this reference; and

**WHEREAS**, staff has recommended that the Mayor and the City Council Members award the ITB to the Contractor, approve the Construction Agreement with Contractor in a not to exceed amount of \$646,829.70, which includes a 10% contingency to address any unforeseen conditions, and authorize the City Manager to execute the Construction Agreement and to expend budgeted funds in furtherance hereof; and

**WHEREAS**, the PWD respectfully request that the Mayor and City Council-Members authorize a budget transfer in the amount of \$389,100.00 from Stormwater Fund “Contractual Services” Account (Account No. 401.80005.500340) to the Stormwater Fund “Construction in Progress” Account (Account No. 401.80005.500650) in order to be able to capitalize the expenses; and

**WHEREAS**, Funding for this request is available in the Public Works Stormwater Fund – Construction in Progress, Account No. 401.80005.500650, from previous Fiscal Years encumbered under Purchase Order 20192047, and the transfer of funds.

**NOW, THEREFORE, BE IT RESOLVED BY THE CITY COUNCIL OF THE CITY OF DORAL AS FOLLOWS:**

**Section 1. Recitals.** The above recitals are confirmed, adopted, and incorporated herein and made part hereof by this reference.

**Section 2. Approval.** The Construction Agreement between the City and Contractor for the Project, in substantially the form provided in Exhibit “A”, in the amount of \$646,829.70 which includes a 10% contingency to address any unforeseen conditions, together with such non-material changes as may be acceptable to the City Manager and approved as to form and legality by the City Attorney, and the transfer of \$389,100.00 from Stormwater Fund “Contractual Services” Account (Account No. 401.80005.500340) to the Stormwater Fund “Construction in Progress” Account (Account No. 401.80005.500650) is hereby approved.

**Section 3. Authorization.** The City Manager is authorized to execute the Construction Agreement and expend budgeted funds on behalf of the City in furtherance hereof. The City Manager is further authorized to negotiate and enter into an agreement with the next highest ranked firm successively, if an agreement cannot be entered into with Contractor, provided the next bidder accepts the contract amount approved above.

**Section 4. Implementation.** The City Manager and the City Attorney are hereby authorized to take such further action as may be necessary to implement the purpose and the provisions of this Resolution.

**Section 5. Effective Date.** This Resolution shall take effect immediately upon adoption.

The foregoing Resolution was offered by Councilmember Cabrera who moved its adoption. The motion was seconded by Councilmember Cabral and upon being put to a vote, the vote was as follows:

Mayor Juan Carlos Bermudez	Yes
Vice Mayor Christi Fraga	Yes
Councilwoman Digna Cabral	Yes
Councilman Pete Cabrera	Yes
Councilwoman Claudia Mariaca	Yes

PASSED AND ADOPTED this 9 day of September, 2020.

  
\_\_\_\_\_  
JUAN CARLOS BERMUDEZ, MAYOR

ATTEST:  
  
\_\_\_\_\_  
CONNIE DIAZ, MMC  
CITY CLERK

APPROVED AS TO FORM AND LEGAL SUFFICIENCY  
FOR THE USE AND RELIANCE OF THE CITY OF DORAL ONLY:

  
\_\_\_\_\_  
LUIS FIGUEREDO, ESQ.  
CITY ATTORNEY

# EXHIBIT “A”

# Bid Tabulation Sheet



**Bid Number** ITB No. 2020-23  
**Bid Name** Canal Bank Stabilization Program: Year 5A Phase II  
**Bid Due Date** 7/30/2020 10:00:00 AM EST

Company	Responded	Address	Bid Amount	Documents	Sent
ATL Diversified.com	7/30/2020	5796 Western Way, Lake Worth, FL 33463	\$726,161.00	Supplier Solicitation Response	Y
Enco, LLC	7/30/2020	5411 SW 25th Court, Pembroke Park, FL 33023	\$588,027.00	Supplier Solicitation Response	Y
Ferreira Construction Company Inc.	7/30/2020	9455 NW 104th Street, Medley, FL 33178	\$659,440.00	Supplier Solicitation Response	Y
Maestre Construction Inc.	7/30/2020	610 W 53 Street, Hialeah, FL 33012	\$779,505.16	Supplier Solicitation Response	Y

Preparer's Name:	Tanya Donigan
Date Prepared:	8/11/2020

**ITB No. 2020-23 YEAR 5A PHASE II CANAL BANK STABILIZATION**

**Bid Tally Sheet**

**Year 5A Phase II**

Item	Description	Unit	Qty.	ENCO LLC		FERREIRA CONSTRUCTION SOUTH DIVISION CO. INC.		ABOR TREE AND LAND LLC		MAESTRE CONSTRUCTION LLC	
				Unit Price	Cost	Unit Price	Cost	Unit Price	Cost	Unit Price	Cost
P-01560-1	Mobilization	LS	1	\$ 29,450.00	\$ 29,450.00	\$ 65,840.00	\$ 65,840.00	\$ 50,000.00	\$ 50,000.00	\$ 31,577.16	\$ 31,577.16
P-01570-1	Maintenance of Traffic	LS	1	\$ 5,000.00	\$ 5,000.00	\$ 10,678.00	\$ 10,678.00	\$ 7,500.00	\$ 7,500.00	\$ 10,000.00	\$ 10,000.00
P-02050-3	15" Metal Pipe Removal	LF	15	\$ 5.00	\$ 75.00	\$ 120.00	\$ 1,800.00	\$ 450.00	\$ 6,750.00	\$ 200.00	\$ 3,000.00
P-02050-4	18" HDPE Pipe Installation	LF	15	\$ 20.00	\$ 300.00	\$ 150.00	\$ 2,250.00	\$ 650.00	\$ 9,750.00	\$ 350.00	\$ 5,250.00
P-02110-1	Clearing and Land Preparation	SY	2132	\$ 3.00	\$ 6,396.00	\$ 42.00	\$ 89,544.00	\$ 15.00	\$ 31,980.00	\$ 20.00	\$ 42,640.00
P-02110-4	Embankment Fill	CY	370	\$ 45.00	\$ 16,650.00	\$ 20.00	\$ 7,400.00	\$ 30.00	\$ 11,100.00	\$ 60.00	\$ 22,200.00
P-02240-1	Stacked Geoweb Excavation	LF	2220	\$ 30.00	\$ 66,600.00	\$ 20.00	\$ 44,400.00	\$ 50.00	\$ 111,000.00	\$ 60.00	\$ 133,200.00
P-02240-2	Stacked Geoweb Installation (Below 2.0 ft-NGVD)	LF	2220	\$ 30.00	\$ 66,600.00	\$ 45.00	\$ 99,900.00	\$ 65.00	\$ 144,300.00	\$ 70.00	\$ 155,400.00
P-02240-3	Stacked Geoweb Installation (2.0-4.5 ft-NGVD)	LF	2220	\$ 84.00	\$ 186,480.00	\$ 45.00	\$ 99,900.00	\$ 55.00	\$ 122,100.00	\$ 65.00	\$ 144,300.00
P-02240-4	Stacked Geoweb Installation (Above 4.5 ft-NGVD)	LF	2220	\$ 47.00	\$ 104,340.00	\$ 45.00	\$ 99,900.00	\$ 45.00	\$ 99,900.00	\$ 55.00	\$ 122,100.00
P-02240-24	Stacked CBS Wrap-Around Culverts	EA	1	\$ 1,500.00	\$ 1,500.00	\$ 9,000.00	\$ 9,000.00	\$ 9,500.00	\$ 9,500.00	\$ 700.00	\$ 700.00
P-02435-1	Staked Turbidity Barrier	LF	4440	\$ 1.50	\$ 6,660.00	\$ 5.00	\$ 22,200.00	\$ 12.00	\$ 53,280.00	\$ 3.00	\$ 13,320.00
P-02435-2	Floating Turbidity Barrier	LF	140	\$ 16.00	\$ 2,240.00	\$ 60.00	\$ 8,400.00	\$ 3.00	\$ 420.00	\$ 15.00	\$ 2,100.00
P-02444-1	Guardrail Installation	LF	38	\$ 60.00	\$ 2,280.00	\$ 50.00	\$ 1,900.00	\$ 300.00	\$ 11,400.00	\$ 50.00	\$ 1,900.00
P-02480-1	Finish Grading and Sodding	SY	2132	\$ 8.00	\$ 17,056.00	\$ 4.00	\$ 8,528.00	\$ 9.25	\$ 19,721.00	\$ 11.50	\$ 24,518.00
P-02481-1	Tree Removal	EA	17	\$ 250.00	\$ 4,250.00	\$ 1,000.00	\$ 17,000.00	\$ 200.00	\$ 3,400.00	\$ 500.00	\$ 8,500.00
P-02525-1	Bedding Stone	CY	470	\$ 95.00	\$ 44,650.00	\$ 90.00	\$ 42,300.00	\$ 48.00	\$ 22,560.00	\$ 40.00	\$ 18,800.00
P-02831-1	Chain Link Fencing	LF	1000	\$ 27.00	\$ 27,000.00	\$ 23.50	\$ 23,500.00	\$ 7.00	\$ 7,000.00	\$ 35.00	\$ 35,000.00
P-02840-1	Manatee Gate	EA	1	\$ 500.00	\$ 500.00	\$ 5,000.00	\$ 5,000.00	\$ 4,500.00	\$ 4,500.00	\$ 5,000.00	\$ 5,000.00
<b>BID TOTAL</b>					<b>\$ 588,027.00</b>		<b>\$ 659,440.00</b>		<b>\$ 726,161.00</b>		<b>\$ 779,505.16</b>

10% Contingency \$ 58,802.70  
 Requested Amount \$ 646,829.70

# City of Doral

## Public Works Department



### Canal Bank Stabilization Program

Program Year

 5A Design Completed

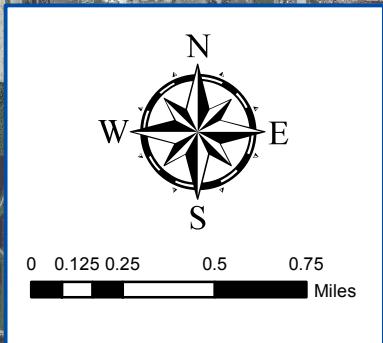



## SECTION 00500 - CONSTRUCTION CONTRACT

This Contract (the "Contract") is dated as of the \_\_\_\_\_ day of \_\_\_\_\_ 20\_\_ by and between the City of Doral (hereinafter called the "CITY") and ENCO, LLC (hereinafter called "CONTRACTOR") located at: 5411 SW 25 Court, Pembroke Park, FL 33023.

CITY and CONTRACTOR, in consideration of the mutual covenants hereinafter set forth, agree as follows:

### **ARTICLE 1 – WORK**

1.1 Project/Work: CONTRACTOR shall complete all Work as specified or indicated in the Contract Documents. The Work is generally described as the following: The Project consists of ***Canal Bank Stabilization Program: Year 5A Phase II, ITB No.2020-23*** all in accordance with the construction drawings.

### **ARTICLE 2 – CITY'S REPRESENTATIVE, ARCHITECT AND ENGINEER**

2.1 It is understood that the CITY will designate a representative for the Work. The CITY'S REPRESENTATIVE referred to in any of the Contract Documents designated herein is **Carlos Arroyo, Public Works Director**, at City of Doral Government Center, 8401 NW 53<sup>rd</sup> Terrace Doral, Florida 33166.

2.2 The CITY'S ARCHITECT referred to in any of the Contract Documents designated herein is \_\_\_\_\_ N/A \_\_\_\_\_, \_\_\_\_\_ N/A \_\_\_\_\_.

2.3 The CITY'S ENGINEER referred to in any of the Contract Documents designated is **Carlos Ortega, P.E.**, at ADA Engineering, Inc., 8550 NW 33 Street, Doral, Florida 33122.

### **ARTICLE 3 – TERM**

3.1 Contract Times. Contract Time will commence on the date the Agreement is executed and shall continue consequently for a period of **one hundred and twenty (120) calendar days**. Work shall be completed ("Final Completion") and shall be ready for final payment in accordance with the Contract Documents within thirty (30) calendar days from the date substantial completion is accepted

3.2 Term. This Contract shall not be effective until it is fully executed between the CITY and the CONTRACTOR. The term of the Contract shall be through the date of final payment unless terminated earlier pursuant to Section 00710 – General Conditions, Article 12, Suspension of Work and Termination.

3.3 Survival of Obligations. Any obligations by the CONTRACTOR, including but not limited to those set forth in Section 00710 – General Conditions, Article 13, Contractor's General Warranty and Guarantee, that would or could occur after the date of expiration or termination of the Contract shall survive the termination or expiration of the Contract.

**3.4** Liquidated Damages. CITY and CONTRACTOR recognize that time is of the essence in this Contract and that the CITY will suffer financial loss if the Work is not completed within the contract times specified in Section 3.1 for the Work above, plus any approved extensions thereof allowed in accordance with the General Conditions. The CONTRACTOR also recognizes the delays, expense and difficulties involved in proving the actual loss suffered by CITY if the Work is not completed on time. Accordingly, instead of requiring any such proof, CITY and CONTRACTOR agree that as liquidated damages for delay (but not as a penalty) CONTRACTOR shall pay CITY \$2,000.00 for each calendar day that expires after the time specified in Section 3.1 for Substantial Completion of the Work. After Final Completion, if CONTRACTOR shall neglect, refuse or fail to complete the remaining Work within the time specified in Section 3.1 for completion and readiness for final payment or any proper extension thereof granted by CITY, CONTRACTOR shall pay CITY \$2,000.00 for each calendar day that expires after the time specified in Section 3.1 for completion and readiness for final payment.

**3.5** Should the Final Completion and acceptance of Work, together with any modification or additions, be delayed beyond the time for performance set in Section 3.1 above because of lack of performance by the CONTRACTOR, it is understood and agreed that aside from any other liquidated damages, all actual additional costs or losses incurred by the CITY including, but not limited to, completion contractor services, financing, professional services, unrealized revenue, will be the responsibility of the CONTRACTOR.

**3.6** Monies due to the CITY under Sections 3.4 and 3.5 shall be deducted from any monies due the CONTRACTOR, or if no money is due or the amount due is insufficient to cover the amount charged the CONTRACTOR shall be liable for said amount.

#### **ARTICLE 4 – CONTRACT PRICE**

**4.1** CITY shall pay CONTRACTOR for completion of the Work in accordance with the Contract Documents an amount in current funds equal to the sum of the amounts determined pursuant to this Article.

**4.1.1** For all Unit Price Work, an amount equal to the sum of the established unit price for each separately identified item of Unit Price Work times the estimated quantity of that item as indicated on the Unit Price Bid Form Section 00410. Estimated quantities are not guaranteed, and determination of actual quantities and classification are to be made by ENGINEER as provided in the Contract Documents.

**4.2** The CONTRACTOR agrees that all specific cash allowances are included in the above Contract Price and have been computed in accordance with the Contract Documents.

#### **ARTICLE 5 – PAYMENT PROCEDURES**

**5.1** CONTRACTOR shall submit Applications for Payment in accordance with the Section 00710 - General Conditions, Article 11, Payments to Contractor and Completion. Applications for Payment will be processed by CITY as provided in the General Conditions.

**5.2** Progress Payments, Retainage. CITY shall make progress payments, deducting the amount from the Contract Price above, on the basis of CONTRACTOR'S Applications for Payment as recommended by the CITY'S REPRESENTATIVE, on or about the last day of each month during construction as provided herein. All such payments will be made in accordance with the schedule of values established in the General Conditions or, in the event there is no schedule of values, as provided in the General Conditions.

**5.2.1** No progress payment shall be made until CONTRACTOR delivers to the CITY complete original partial releases of all liens and claims signed by all Subcontractors, materialmen, suppliers, and vendors, indicating amount of partial payment, on a form approved by the CITY, and an affidavit that so far as the CONTRACTOR has knowledge or information, the releases include and cover all Materials and Work for which a lien or claim could be filed for work completed to date. CONTRACTOR shall also include red-line as-builts and an updated progress schedule.

**5.3** The CONTRACTOR agrees that ten percent (10%) of the amount due for Work as set forth in each Application for Payment shall be retained by CITY for each Progress Payment until Final Payment, as defined in Section 00710 - General Conditions, Article 11, Payments to Contractor and Completion.

**5.3.1** Prior to Substantial Completion, progress payments will be made in an amount equal to the percentage indicated above, but, in each case, less the aggregate of payments previously made and less such amounts as CITY'S REPRESENTATIVE shall determine, or CITY may withhold, in accordance with the General Conditions.

**5.4** The payment of any Application for Payment by CITY, including the Final Request, does not constitute approval or acceptance by CITY of any item of the Work in such Request for Payment, nor shall it be construed as a waiver of any of CITY's rights hereunder or at law or in equity.

**5.5** The Final Application for Payment by CONTRACTOR shall not be made until the CONTRACTOR delivers to the CITY complete original releases of all liens and claims signed by all Subcontractors, materialmen, suppliers, and vendors on a form approved by the CITY, and an affidavit that so far as the CONTRACTOR has knowledge or information, the releases include and cover all Materials and Work for which a lien or claim could be filed. The CONTRACTOR may, if any Subcontractor, materialmen, supplier or vendor refuses to furnish the required Final Waiver of Lien, furnish a bond satisfactory to CITY to defend and indemnify CITY and any other property owner, person or entity CITY may be required to indemnify against any lien or claim.

**5.6** Final Payment. Upon final completion and acceptance of the Work in accordance with the General Conditions, CITY shall pay the remainder of the Contract Price and any retainage as recommended by the CITY'S REPRESENTATIVE.

## **ARTICLE 6 – INSURANCE/INDEMNIFICATION.**

**6.1** Insurance. The CONTRACTOR shall secure and maintain throughout the duration of this Contract, insurance of such type and in such amounts necessary to protect its interest and the interest

of the CITY against hazards or risks of loss as specified in the General Conditions of the Contract Documents.

**6.2** Indemnification. The CONTRACTOR shall indemnify, defend and hold harmless the CITY, their officials, agents, employees, and volunteers as set forth in General Conditions of the Contract Documents.

#### **ARTICLE 7 – CONTRACTOR’S REPRESENTATIONS.**

In order to induce CITY to enter into this Contract, CONTRACTOR makes the following representations:

**7.1** CONTRACTOR has examined and carefully studied the Contract Documents (including the Addenda) and the other related data identified in the Bidding Documents including “technical data.”

**7.2** CONTRACTOR has visited the site and become familiar with and is satisfied as to the general, local and site conditions that may affect cost, progress, performance or furnishing of the Work.

**7.3** CONTRACTOR is familiar with and is satisfied as to all federal, state and local Laws and Regulations that may affect cost, progress, performance and furnishing of the Work.

**7.4** CONTRACTOR has made, or caused to be made, examinations, investigations, tests, or studies as necessary to determine surface and subsurface conditions at or on the site. CONTRACTOR acknowledges that CITY does not assume responsibility for the accuracy or completeness of information and data shown or indicated in the Contract Documents with respect to underground facilities at or contiguous to the site. CONTRACTOR has obtained and carefully studied (or assumes responsibility for having done so) all such additional supplementary examinations, investigations, explorations, tests, studies and data concerning conditions (surface, subsurface and Underground Facilities) at or contiguous to the site or otherwise which may affect cost, progress, performance or furnishing of the Work or which relate to any aspect of the means, methods, techniques, sequences and procedures of construction to be employed by CONTRACTOR and safety precautions and programs incident thereto. CONTRACTOR does not consider that any additional examinations, investigations, explorations, tests, studies or data are necessary for the performance and furnishing of the Work at the Contract Price, within the Contract Times and in accordance with the other terms and conditions of the Contract Documents.

**7.5** The CONTRACTOR is aware of the general nature of Work to be performed by CITY and others at the site that relates to the Work as indicated in the Contract Documents.

**7.6** The CONTRACTOR has correlated the information known to CONTRACTOR, information and observations obtained from visits to the site, reports and drawings identified in the Contract Documents and all additional examinations, investigations, explorations, tests, studies and data with the Contract Documents.

**7.7** The CONTRACTOR has given the CITY’S REPRESENTATIVE written notice of all conflicts, errors, ambiguities or discrepancies that CONTRACTOR has discovered in the Contract Documents and the written resolution thereof by the CITY’S REPRESENTATIVE is acceptable to CONTRACTOR, and the

Contract Documents are generally sufficient to indicate and convey understanding of all terms and conditions for performance and furnishing of the Work.

**7.8** The CONTRACTOR warrants the following:

**7.8.1** Anti-Discrimination: The CONTRACTOR agrees that it will not discriminate against any employees or applicants for employment or against persons for any other benefit or service under this Contract because of race, color, religion, sex, national origin, or physical or mental handicap where the handicap does not affect the ability of an individual to perform in a position of employment, and to abide by all federal and state laws regarding non-discrimination.

**7.8.2** Anti-Kickback: The CONTRACTOR warrants that no person has been employed or retained to solicit or secure this Contract upon an agreement or understanding for a commission, percentage, brokerage or contingent fee, and that no employee or officer of the CITY or any other applicable federal or state agency, has any interest, financially or otherwise, in the Project. For breach or violation of this warranty, the CITY shall have the right to annul this Contract without liability or, in its discretion, to deduct from the Contract Price or consideration, the full amount of such commission, percentage, brokerage or contingent fee.

**7.8.3** Licensing and Permits: The CONTRACTOR warrants that it shall have, prior to commencement of work under this Contract and at all times during said work, all required licenses and permits whether federal, state, County or City.

**7.8.4** Public Entity Crime Statement: The CONTRACTOR warrants that it has not been placed on the convicted vendor list following a conviction for public entity crime, as specified in Section 00456, of the Instructions to Bidders.

**ARTICLE 8 – CONTRACT DOCUMENTS.**

**8.1** The Contract Documents listed below, which are listed in their order of precedence for the purpose of resolving conflicts, errors and discrepancies, by this reference shall become a part of the Contract as though physically attached as a part thereof:

**8.1.1** Change Orders.

**8.1.2** Field Orders.

**8.1.3** Contract for Construction.

**8.1.4** Exhibits to this Contract.

**8.1.5** Supplementary Conditions.

**8.1.6** General Conditions.

**8.1.7** Any federal, state, county or city permits for the Project

- 8.1.8** Specifications bearing the title: (N/A)
- 8.1.9** Drawings consisting of a cover sheet and inclusive of all sheets bearing the following general titles: **“Canal Bank Stabilization Program: Year 5A Phase II, ITB No. 2020-23”**
- 8.1.10** Bid Documents, including but not limited to: Addendum, Invitation to Bid, Instructions to Bidders, Bid Form provided by CONTRACTOR, Notice of Award and Notice to Proceed.
- 8.1.11** Addenda subject matter takes the same precedence of the respective subject matter that it is modifying. Furthermore, each subsequent addendum takes precedence over previous addenda.
- 8.1.12** The documents listed above shall be incorporated into this Contract (except as expressly noted otherwise above).
- 8.1.13** There are no Contract Documents other than those listed above in this Article. The Contract Documents may only be amended, modified or supplemented as provided in the General Conditions.
- 8.1.14** The Contract Documents shall remain the property of the CITY. The CONTRACTOR shall have the right to keep one record set of the Contract Documents upon completion of the Project; provided; however, that in no event shall the CONTRACTOR use, or permit to be used, any or all of such Contract Documents on other projects without the City’s prior written authorization.
- 8.1.15** The General Conditions discuss the bond and surety requirements of the CITY. This Contract does [x], does not [ ] require bonds. If the Contract does not require bonds, the references to bonds in the General Conditions do not apply to this Contract.

## **ARTICLE 9 – MISCELLANEOUS.**

**9.1** Terms used in this Contract which are defined in Article 1 of the General Conditions will have the meanings indicated in the General Conditions. Terms used in Article 1 of the Instructions to Bidders also apply to this Contract.

**9.2** Except as otherwise provided in the Contract Documents with respect to subcontractors, no assignment by a party hereto of any rights under or interests in the Contract Documents will be binding on another party thereto without the written consent of the party sought to be bound; and, specifically but without limitation, moneys that may become due and moneys that are due may not be assigned without such consent (except to the extent that the effect of this restriction may be limited by law), and unless specifically stated to the contrary in any written consent to an assignment no assignment will release or discharge the assignor from any duty or responsibility under the Contract Documents.

**9.3** CITY and CONTRACTOR each binds itself, its partners, successors, assigns and legal representatives to the other party hereto, its partners, successors, assigns and legal representatives in respect to all covenants, agreements and obligations contained in the Contract Documents.

**9.4 Severability.** Should any provision, paragraph, sentence, word, or phrase contained in this Contract be determined by a court of competent jurisdiction to be invalid, illegal, or otherwise unenforceable under the laws of the State of Florida, such provision, paragraph, sentence, word, or phrase shall be deemed modified to the extent necessary in order to conform with such laws, then shall be deemed severable, and in this Contract, shall remain unmodified and in full force and effect.

**9.5 Remedies.** If and when any default of this Contract occurs, the CITY may avail itself of any legal or equitable remedies that may apply, including, but not limited to, actual damages and specific performance. Such remedies may be exercised in the sole discretion of the CITY. Nothing contained in this Contract shall limit the CITY from pursuing any legal or equitable remedies that may apply.

**9.6 Access to Public Records.** The CONTRACTOR shall comply with the applicable provisions of Chapter 119, Florida Statutes. The CITY shall have the right to immediately terminate this contract for the refusal by the Contractor to comply with Chapter 119, Florida Statutes. The Contractor shall retain all records associated with this Contract for a period of five (5) years from the date of Final Payment or Termination of this Contract.

**9.7 Inspection and Audit.** During the term of this Contract and for five (5) years from the date of Termination, the CONTRACTOR shall allow CITY representatives access during reasonable business hours to CONTRACTOR'S records related to this Contract for the purposes of inspection or audit of such records. If upon an audit of such records, the CITY determines the CONTRACTOR was paid for services not performed, upon receipt of written demand by the CITY, the CONTRACTOR shall remit such payments to the CITY.

**9.8 Counterparts.** This contract may be signed in one or more counterparts, each of which when executed shall be deemed an original and together shall constitute one and the same instrument.

**9.9 Notices.** Whenever any party is required to give or deliver any notice to any other party, or desires to do so, such notices shall be sent via certified mail or hand delivery to:

FOR CITY:

Albert P. Childress, City Manager  
City of Doral  
8401 NW 53<sup>rd</sup> Terrace  
Doral, Florida 33166

WITH COPY TO:

Luis Figueredo, Esq.  
City Attorney  
City of Doral  
8401 NW 53<sup>rd</sup> Terrace  
Doral, Florida 33166

FOR CONTRACTOR:

Wilson Sanchez, President

ENCO, LLC

5411 SW 25 Court

Pembroke Park, FL 33023

**9.10** WAIVER OF JURY TRIAL AND VENUE. The CITY and CONTRACTOR knowingly, irrevocably, voluntarily and intentionally waive any right either may have to a trial by jury in State and or Federal court proceedings in respect to any action, proceeding, lawsuit or counterclaim based upon the Contract, arising out of, under, or in connection with the Work, or any course of conduct, course of dealing, statements or actions or inactions of any party. The venue for any lawsuit arising out of this Contract shall be in Miami-Dade County, Florida.

**9.11** Attorneys' Fees. If either the CITY or CONTRACTOR is required to enforce the terms of the Contract by court proceedings or otherwise, whether or not formal legal action is required, the prevailing party shall be entitled to recover from the other party all such costs and expenses, including, but not limited to, court costs, and reasonable attorneys' fees at the trial and appellate level.

**9.12** Amendments. This Contract may only be amended by the prior written approval of the parties or by execution of a Change Order in the form attached hereto as Exhibit "B".



IN WITNESS WHEREOF, the parties hereto have made and executed this Contract on the respective dates under each signature: THE CITY OF DORAL, FLORIDA, signing by and through its City Manager, authorized to execute same by Council action on the \_\_\_\_\_ day of \_\_\_\_\_, 20\_\_\_\_, and by \_\_\_\_\_(Contractor), signing by and through its \_\_\_\_\_, duly authorized to execute same.

WITNESS

CONTRACTOR

By: \_\_\_\_\_  
(Signature and Corporate Seal)

\_\_\_\_\_  
(Contractor)

\_\_\_\_\_  
(Print Name and Title)

\_\_\_\_\_  
(Signature)

\_\_\_\_\_  
(Print Name and Title)

\_\_\_\_\_ day of \_\_\_\_\_, 20\_\_\_\_.

ATTEST

CITY OF DORAL

\_\_\_\_\_  
Connie Diaz, City Clerk

\_\_\_\_\_  
Albert P. Childress, City Manager

APPROVED AS TO FORM AND LEGALITY FOR THE USE  
AND BENEFIT OF THE CITY OF DORAL ONLY:

\_\_\_\_\_  
Luis Figueredo, Esq., City Attorney

*(\*) In the event that the Contractor is a corporation, there shall be attached to each counterpart a certified copy of a resolution of the board of the corporation, authorizing the officer who signs the contract to do so in its behalf.*

SOLICITATION RESPONSE FORM

**BIDDERS MUST ATTACH THIS FORM TO THE EXTERIOR OF THE SEALED PACKET**

Name: "ITB No. 2020-23 Canal Bank Stabilization Program: Year 5A Phase II"

Due Date: July 23<sup>rd</sup>, 2020 at 10:00 am

Delivery Location: CITY OF DORAL  
CITY CLERK'S OFFICE  
8401 NW 53<sup>RD</sup> TERRACE  
DORAL, FL 33166

Submitted By: ENCO, LLC  
(Name of company and address) \_\_\_\_\_  
  
5411 SW 25th Ct  
\_\_\_\_\_  
  
Pembroke Park, FL 33023  
\_\_\_\_\_

PLEASE DO NOT TAPE BELOW THIS LINE

---

**For Office Use Only:**

Date and Time Received:

Received by: \_\_\_\_\_

# BID PACKAGE

## CITY OF DORAL



ITB No. 2020-23 | Canal Bank Stabilization Program: Year 5A, Phase II  
July 30, 2020 | ENCO, LLC



**BUILDING FLORIDA**





# TABLE OF CONTENTS

1. Section 00300 – Trench Safety
2. Section 00410 – Bid Form
3. Section 00420 – Award Preference for Identical Tie Bids
4. Section 00432 – Bid Bond
5. Section 00434 – List of Proposed Subcontractors
6. Section 00450 – Bidder Qualification Statement
7. Section 00454 – Non Collusion Affidavit
8. Section 00456 – Public Entity Crimes
9. Statement of No Response
10. Solicitation Response Form
11. General Information Worksheet
12. Business Entity Affidavit (Vendor/Bidder Disclosure)
13. No Contingency Affidavit
14. Americans with Disabilities Act (ADA)  
Disability Nondiscrimination Statement
15. Drug Free Workplace Program
16. Copeland Act Anti-Kickback Affidavit
17. Cone of Silence Certification
18. Equal Employment Opportunity Certification
19. Respondent's Certification
20. ITB Signature for Sole Proprietor or Partnership
21. ITB Signature Page for Corporation
22. Addendums
23. Resumes
24. Insurance Certificates
25. GC License
26. Equipment Resources
27. Other Documents:
  - a. Invitation to Bid
  - b. Project Overview
  - c. Schedule of Events
  - d. Table of Contents
  - e. Section 00200 – Instructions to Bidders
  - f. Section 00500 – Construction Contract
  - g. Section 00510 – Notice to Award
  - h. Section 00550 – Notice to Proceed
  - i. Section 00600 – Bonds & Certificates
  - j. Section 00612 – Form of Payment Bond
  - k. Section 00614 – Form of Performance Bond
  - l. Section 00620 – Acknowledgement of  
Conformance with OSHA
  - m. Section 00710 – General Conditions
  - n. Section 00810 – Special Conditions
  - o. Attachments:
    - i. Exhibit A: Insurance
    - ii. Exhibit B: Change Order Form
    - iii. Exhibit C: Construction Plans
    - iv. Exhibit D: Section 02240 Stacked Bank Stabilization  
System

**SECTION 00300**

**TRENCH SAFETY FORM**

This form must be completed and signed by the Bidder.

Failure to complete this form may result in the bid being declared non-responsive.

Bidder acknowledges that the Florida Trench Safety Act, Section 553.60 *et seq*, Fla. Stat. which became effective October 1, 1990, shall be in effect during the period of construction of the Project. The Bidder by signing and submitting the Bid is, in writing, assuring that it will perform any trench excavation in accordance with applicable trench safety standards. The Bidder further identifies the following separate item of cost of compliance with the applicable trench safety standards as well as the method of compliance:

**Method of Compliance**

**Cost**

Trench box if needed

Total: \$ 4,000.00

Bidder acknowledges that this cost is included in the applicable items of the Bid and in the Total Base Bid. Failure to complete the above may result in the bid being declared non-responsive.

The Bidder is, and the CITY and ENGINEER are not, responsible to review or assess Bidder’s safety precautions, programs of costs, of the means, methods, techniques or technique adequacy, reasonableness of cost, sequences of procedures of any safety precaution, program or cost, including but not limited to, compliance with any and all requirements of Section 553.60 *et. seq.*, Fla. Stat. cited as the “Trench Safety Act”. Bidder is, and the CITY and ENGINEER are not, responsible to determine, if any safety or safety related standards apply to the Project, including but not limited to, the “Trench Safety Act”.

Isabella Micolta

Witness Signature

Isabella Micolta

Printed Name

07/20/2020

Date

Wilson Sanchez

Bidder’s Signature

Wilson Sanchez

Printed Name

Managing Member

Title

07/20/2020

Date

**SECTION 00410 - BID FORM**  
**ITB No. 2020-23**

THIS BID IS SUBMITTED TO:

City of Doral  
8401 NW 53rd Terrace  
Doral, Florida 33166

1. The undersigned BIDDER proposes and agrees, if this Bid is accepted, to enter into an agreement with The City of Doral in the form included in the Contract Documents to perform and furnish all Work as specified or indicated in the Contract Documents for the Contract Price and within the Contract Time indicated in this Bid and in accordance with the other terms and conditions of the Contract Documents.
2. BIDDER accepts all of the terms and conditions of the Advertisement or Invitation to Bid and Instructions to BIDDER'S, including without limitation those dealing with the disposition of Bid Security. This Bid will remain subject to acceptance for 90 days after the day of Bid opening. BIDDER agrees to sign and submit the Agreement with the Bonds and other documents required by the Bidding Requirements within ten days after the date of City's Notice of Award.
3. In submitting this Bid, BIDDER represents, as more fully set forth in the Agreement, that:

(a) BIDDER has examined copies of all the Bidding Documents and of the following Addenda (receipt of all which is hereby acknowledged.)

Addendum No. <u>1</u>	Dated: <u>07/21/2020</u>
Addendum No. _____	Dated: _____
Addendum No. _____	Dated: _____
Addendum No. _____	Dated: _____

- (b) BIDDER has familiarized themselves with the nature and extent of the Contract Documents, Work, site, locality, and all local conditions and Law and Regulations that in any manner may affect cost, progress, performance, or furnishing of the Work.
- (c) BIDDER has studied carefully all reports and drawings of subsurface conditions and drawings of physical conditions.
- (d) BIDDER has obtained and carefully studied (or assumes responsibility for obtaining and carefully studying) all such examinations, investigations, explorations, tests and studies (in addition to or to supplement those referred to in (c) above) which pertain to the subsurface or physical conditions at the site or otherwise may affect the cost, progress, performance, or furnishing of the Work at the Contract Price, within the Contract Time and in accordance with the other terms and conditions of the Contract Documents, and no additional examinations, investigations, explorations, tests, reports or similar

information or data are or will be required by BIDDER for such purposes.

- (e) BIDDER has correlated the results of all such observations, examinations, investigations, explorations, tests, reports, and studies with the terms and conditions of the Contract Documents.
- (f) BIDDER has given the City written notice of all conflicts, errors, discrepancies that it has discovered in the Contract Documents and the written resolution thereof by the City is acceptable to BIDDER.
- (g) This Bid is genuine and not made in the interest of or on behalf of any undisclosed person, firm or corporation and is not submitted in conformity with any agreement or rules of any group, association, organization, or corporation; BIDDER has not directly or indirectly induced or solicited any other BIDDER to submit a false or sham Bid; BIDDER has not solicited or induced any person, firm or corporation to refrain from bidding; and BIDDER has not sought by collusion to obtain for itself any advantage over any other BIDDER or over the City.

4. BIDDER understands and agrees that this is a unit rate contract. **The prices submitted on the bid form are to furnish and deliver all of the Work complete in place.** The quantities provided on the form are for the purpose of Bid Evaluation and should be considered estimates only. Contractor's unit prices will not be adjusted to reflect any deviation from the provided quantities. As such the Contractor shall furnish all labor, materials, equipment, tools, supervision, safety measures, and services necessary to provide the stated units of work for the Bid Price of:

**Base Bid**

**Fiscal Year 5A Phase II: Dressel's Dairy Canal (NW 41 St from NW 79<sup>th</sup> Ave to 836/Palmetto Expressway):**

Item Number	Bid Item	Description	Unit	Qty.	Unit Price	Cost
1	P-01560-1	Mobilization	1	LS	\$29,450.00	\$29,450.00
2	P-01570-1	Maintenance of Traffic	1	LS	\$5,000.00	\$5,000.00
3	P-02050-3	15" Metal Pipe Removal	15	LF	\$5.00	\$75.00
4	P-02050-4	18" HDPE Pipe Installation	15	LF	\$20.00	\$300.00
5	P-02110-1	Clearing and Land Preparation	2132	SY	\$3.00	\$6,396.00
6	P-02110-4	Embankment Fill	370	CY	\$45.00	\$16,650.00
7	P-02240-1	Stacked Geoweb Excavation	2220	LF	\$30.00	\$66,600.00
8	P-02240-2	Stacked Geoweb Installation (Below 2.0 ft-NGVD)	2220	LF	\$30.00	\$66,600.00
9	P-02240-3	Stacked Geoweb Installation (2.0-4.5 ft-NGVD)	2220	LF	\$84.00	\$186,480.00
10	P-02240-4	Stacked Geoweb Installation (Above 4.5 ft-NGVD)	2220	LF	\$47.00	\$104,340.00





work orders executed under the terms of this contract.

6. Communications concerning this Bid shall be addressed to:

BIDDER: ENCO, LLC

Address: 5411 SW 25th Ct., Pembroke Park, FL 33023

Telephone: 954-342-2466

Facsimile Number: 954-920-9040

Attention: Wilson Sanchez

7. The terms used in this Bid which are defined in the General Conditions of the Contract included as part of the Contract documents have the meanings assigned to them in the General Conditions.

SUBMITTED THIS 30 DAY OF July, 20 20

N/A

If BIDDER is:

**AN INDIVIDUAL**

By: \_\_\_\_\_ (SEAL)  
(Individual's Name)

Doing business as: \_\_\_\_\_

Business address: \_\_\_\_\_  
\_\_\_\_\_

Phone No.: \_\_\_\_\_ Facsimile No.: \_\_\_\_\_

N/A

**A PARTNERSHIP**

By: \_\_\_\_\_ (SEAL)  
(Firm's Name)

\_\_\_\_\_  
(General Partner)

Business address: \_\_\_\_\_  
\_\_\_\_\_

Phone No.: \_\_\_\_\_ Facsimile No.: \_\_\_\_\_

A CORPORATION

By: ENCO, LLC  
(Corporation Name)

Florida  
(State of Incorporation)

By: Wilson Sanchez  
(Name of Person Authorized to Sign)

Managing Member  
(Title)

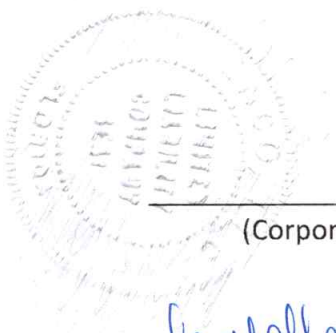

\_\_\_\_\_  
(Corporate Seal)

A handwritten signature in blue ink, appearing to read "Wilson Sanchez", is written over a horizontal line.

Attest: Isabella Micolta  
Isabella Micolta

Wilson Sanchez  
(President)

Business address: 5411 SW 25th Ct

Pembroke Park, FL 33023

Phone No.: 954-342-2466

Facsimile No.: 954-920-9040

N/A

**A JOINT VENTURE**

By: \_\_\_\_\_  
(Name)

\_\_\_\_\_  
(Address)

By: \_\_\_\_\_  
(Name)

\_\_\_\_\_  
(Address)

(Each joint venture must sign. The manner of signing for each individual, partnership, and corporation that is a party to the joint venture should be in the manner indicated above.)

CERTIFICATE OF AUTHORITY

(IF CORPORATION)

STATE OF Florida )

) SS:

COUNTY OF Broward )

I HEREBY CERTIFY that a meeting of the Board of DIRECTORS of the  
ENCO, LLC

a Corporation existing under the laws of the State of Florida,

held on March 7, 2002, the following resolution was duly passed and adopted:

“RESOLVED, that, as President of the Corporation, be and is hereby authorized to execute the Bid dated, July 23, 2020, to the City of Doral and this Corporation and that their execution thereof, attested by the Secretary of the Corporation, and with the Corporate Seal affixed, shall be the official act and deed of this Corporation”.

IN WITNESS WHEREOF, I have hereunto set my hand and affixed the official seal of the Corporation this 23, day of July, 2020.

Secretary: Isabella Micolta  
Isabella Micolta

(SEAL)

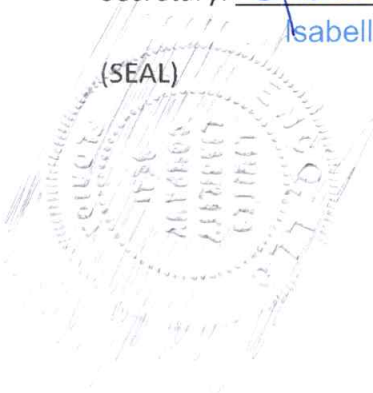

N/A

**CERTIFICATE OF AUTHORITY**

**(IF PARTNERSHIP)**

STATE OF \_\_\_\_\_ )

) SS:

COUNTY OF \_\_\_\_\_ )

I HEREBY CERTIFY that a meeting of the Partners of the

\_\_\_\_\_  
\_\_\_\_\_

a Corporation existing under the laws of the State of \_\_\_\_\_,  
held on \_\_\_\_\_, 20\_\_\_\_, the following resolution was duly passed and adopted:

“RESOLVED, that, \_\_\_\_\_, as \_\_\_\_\_ of the Partnership, be and is  
hereby authorized to execute the Bid dated, \_\_\_\_\_, 20\_\_\_\_, to the City of  
Doral and this Partnership and that their execution thereof, attested by the \_\_\_\_\_,  
shall be the official act and deed of this Partnership”.

I further certify that said resolution is now in full force and effect.

IN WITNESS WHEREOF, I have hereunto set my hand this \_\_\_\_\_, day of \_\_\_\_\_, 20\_\_\_\_.

Secretary: \_\_\_\_\_

(SEAL)

N/A

**CERTIFICATE OF AUTHORITY**

**(IF JOINT VENTURE)**

STATE OF \_\_\_\_\_ )

) SS:

COUNTY OF \_\_\_\_\_ )

I HEREBY CERTIFY that a meeting of the Principals of the

\_\_\_\_\_  
\_\_\_\_\_

a Corporation existing under the laws of the State of \_\_\_\_\_,  
held on \_\_\_\_\_, 20\_\_\_\_, the following resolution was duly passed and adopted:

“RESOLVED, that, \_\_\_\_\_, as \_\_\_\_\_ of the Joint Venture, be and is  
hereby authorized to execute the Bid dated, \_\_\_\_\_, 20\_\_\_\_, to the City of  
Doral official act and deed of this Joint Venture”.

I further certify that said resolution is now in full force and effect.

IN WITNESS WHEREOF, I have hereunto set my hand this \_\_\_\_\_, day of \_\_\_\_\_, 20\_\_\_\_.

Secretary: \_\_\_\_\_

(SEAL)

END OF SECTION



## SECTION 00420 - AWARD PREFERENCE FOR IDENTICAL TIE BIDS

Whenever two or more Bids which are equal with respect to price, quality, and service are received by the City or by any political subdivision for the procurement of commodities or contractual services, a Bid received from a business that certifies that it has implemented a drug-free workplace program shall be given preference in the award process. Established procedures for processing tie Bids will be followed if none of the tied vendors have a drug-free workplace program. In order to have a drug-free workplace program, a business shall:

- 1) Publish a statement notifying employees that the unlawful manufacture, distribution, dispensing, possession, or use of a controlled substance is prohibited in the workplace and specifying the actions that will be taken against employees for violations of such prohibition.
- 2) Inform employees about the dangers of drug abuse in the workplace, the City's policy of maintaining a drug-free workplace, any available drug counseling, rehabilitation, and employee assistance programs, and the penalties that may be imposed upon employees for drug abuse violations.
- 3) Give each employee engaged in providing the commodities or contractual services that are under Bid a copy of the statement specified in subsection (1).
- 4) In the statement specified in subsection (1), notify the employees that, as a condition of working on the commodities or contractual services that are under Bid, the employee will abide by the terms of the statement and will notify the employer of any conviction of, or plea of guilty or nolo contendere to, any violation of chapter 893 or of any controlled substance law of the United States or any state, for a violation occurring in the workplace no later than five days after such conviction.
- 5) Impose a sanction on, or require the satisfactory participation in a drug abuse assistance or rehabilitation program, if such is available in the employee's community, by any employee who is so convicted.
- 6) Make a good faith effort to continue to maintain a drug-free workplace through implementation of this section.

As the person authorized to sign the statement, I certify that this firm complies fully with the above requirements.



BIDDERS SIGNATURE: \_\_\_\_\_  
Wilson Sanchez / ENCO, LLC

END OF SECTION

**SECTION 00432 - BID BOND**

STATE OF FLORIDA )

) SS:

COUNTY OF BROWARD )

KNOW ALL MEN BY THESE PRESENTS, that we, ENCO, LLC, as Principal, and Travelers Casualty and Surety Company of America, as Surety, are held firmly bound unto the City of Doral, a municipal corporation of the State of Florida in the sum of Five Percent Dollars (\$ 5%), lawful money of the United States, for the payment of which sum and truly to be made, we bind ourselves, our heirs, executors, administrators and successors jointly and severally, firmly by these presents.

THE CONDITION OF THIS OBLIGATION IS SUCH that whereas the Principal has submitted the accompanying Bid dated, JULY 23rd, 2020 for: City of Doral 8401 NW 53rd Terrace, Doral FL 33166  
Canal Bank Stabilization Program: 5A Phase II  
ITB No. 2020-23

WHEREAS, it was a condition precedent to the submission of said Bid that a or Bid Bond in the amount of five percent (5%) of the Base Bid be submitted with said Bid as a guarantee that the BIDDER would, if awarded the Contract, enter into a written Contract with the City for the performance of said Contract, within ten (10) consecutive calendar days after written notice having been given of the Award of the Contract.

NOW, THEREFORE, the conditions of this obligation are such that if the Principal within ten (10) consecutive calendar days after written notice of such acceptance, enters into a written Contract with the City of Doral and furnishes the Performance and Payment Bonds, satisfactory to the City, each in an amount equal to one hundred percent (100%) of the Contract Price, and provides all required Certificates of Insurance, then this obligation shall be void; otherwise the sum herein stated shall be due and payable to the City of Doral and the Surety herein agrees to pay said sum immediately, upon demand of the City, in good and lawful money of the United States of America, as liquidated damages for failure thereof of said Principal.

IN WITNESS WHEREOF, the above bonded parties have executed this instrument under their several seals this 20 day of JULY, 2020, the name and the corporate seal of each corporate party being hereto affixed and these presents being duly signed by its undersigned representative.

IN PRESENCE OF:

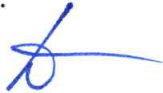

\_\_\_\_\_  
(Individual or Partnership Principal)  
CORPORATION

ENCO, LLC

\_\_\_\_\_  
(Business Name)

(SEAL)

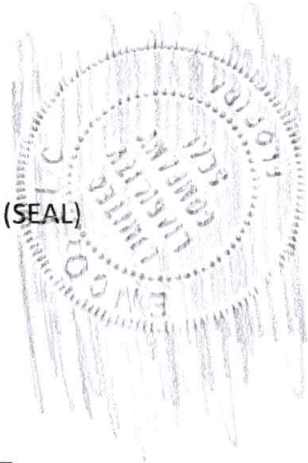

5411 SW 25th COURT

\_\_\_\_\_  
(Business Address)

PEMBROKE PARK, FL 33023

\_\_\_\_\_  
(City/State/Zip)

954-342-2466

\_\_\_\_\_  
(Business Phone)

ATTEST:

POWER OF ATTORNEY ATTACHED

Travelers Casualty and Surety Company of America

\_\_\_\_\_  
(Corporate Surety)\*

By:

\_\_\_\_\_  
Florida Resident Agent and Attorney In-Fact

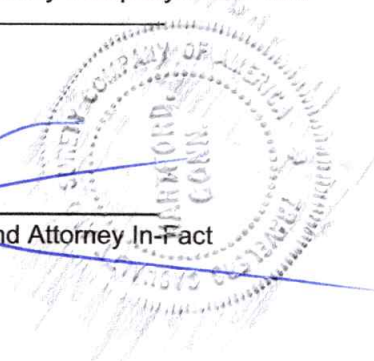

\*Impress Corporate Seal



IMPORTANT

Surety companies executing bonds must appear on the Treasury Department's most current list (circular 570 as amended) and be authorized to transact business in the State of Florida.

Signed, sealed and delivered in the presence of:

Isabella Nicolta

Isabella Nicolta  
(Printed Name)

By:   
Wilson Sanchez  
Managing Member  
(Title)

ACKNOWLEDGMENT

State of Florida

County of Broward

On this the 20<sup>th</sup> day of July, 2020, before me, the undersigned Notary Public of the State of Florida, personally appeared

Wilson Sanchez and Isabella Nicolta  
(Name(s) of individual(s) who appeared before notary)

Whose name(s) is/are Subscribed to the within instrument, and he/she/they acknowledge that he/she/they executed it.

WITNESS in my hand and official seal.



NOTARY PUBLIC, STATE OF FLORIDA

NOTARY PUBLIC:

SEAL OF OFFICE:



**Nairim E. Armstrong**  
**Comm # GG952038**  
**Expires Jan. 28, 2024**  
**Bonded Thru Aaron Notary**

Nairim Armstrong

(Name of Notary Public: Print, Stamp, or Type as Commissioned)

- Personally known to me, or
- Personally identification:

\_\_\_\_\_

(Type of Identification Produced)

- Did take an oath, or
- Did NOT take an oath,

OPTIONAL INFORMATION:

Type of Document \_\_\_\_\_ Number of Pages: \_\_\_\_\_

Number of Signatures Notarized: 2

END OF SECTION

**TRAVELERS**

**Travelers Casualty and Surety Company of America  
Travelers Casualty and Surety Company  
St. Paul Fire and Marine Insurance Company**

**POWER OF ATTORNEY**

**KNOW ALL MEN BY THESE PRESENTS:** That Travelers Casualty and Surety Company of America, Travelers Casualty and Surety Company, and St. Paul Fire and Marine Insurance Company are corporations duly organized under the laws of the State of Connecticut (herein collectively called the "Companies"), and that the Companies do hereby make, constitute and appoint **NESTOR J RODRIGUEZ** of **WESTON Florida**, their true and lawful Attorney-in-Fact to sign, execute, seal and acknowledge any and all bonds, recognizances, conditional undertakings and other writings obligatory in the nature thereof on behalf of the Companies in their business of guaranteeing the fidelity of persons, guaranteeing the performance of contracts and executing or guaranteeing bonds and undertakings required or permitted in any actions or proceedings allowed by law.

**IN WITNESS WHEREOF**, the Companies have caused this instrument to be signed, and their corporate seals to be hereto affixed, this **17th** day of **January, 2019**.



State of Connecticut  
City of Hartford ss.

By:   
Robert L. Raney, Senior Vice President

On this the **17th** day of **January, 2019**, before me personally appeared **Robert L. Raney**, who acknowledged himself to be the Senior Vice President of Travelers Casualty and Surety Company of America, Travelers Casualty and Surety Company, and St. Paul Fire and Marine Insurance Company, and that he, as such, being authorized so to do, executed the foregoing instrument for the purposes therein contained by signing on behalf of said Companies by himself as a duly authorized officer.

**IN WITNESS WHEREOF**, I hereunto set my hand and official seal.

My Commission expires the **30th** day of **June, 2021**



  
Anna P. Nowik, Notary Public

This Power of Attorney is granted under and by the authority of the following resolutions adopted by the Boards of Directors of Travelers Casualty and Surety Company of America, Travelers Casualty and Surety Company, and St. Paul Fire and Marine Insurance Company, which resolutions are now in full force and effect, reading as follows:

**RESOLVED**, that the Chairman, the President, any Vice Chairman, any Executive Vice President, any Senior Vice President, any Vice President, any Second Vice President, the Treasurer, any Assistant Treasurer, the Corporate Secretary or any Assistant Secretary may appoint Attorneys-in-Fact and Agents to act for and on behalf of the Company and may give such appointee such authority as his or her certificate of authority may prescribe to sign with the Company's name and seal with the Company's seal bonds, recognizances, contracts of indemnity, and other writings obligatory in the nature of a bond, recognizance, or conditional undertaking, and any of said officers or the Board of Directors at any time may remove any such appointee and revoke the power given him or her; and it is

**FURTHER RESOLVED**, that the Chairman, the President, any Vice Chairman, any Executive Vice President, any Senior Vice President or any Vice President may delegate all or any part of the foregoing authority to one or more officers or employees of this Company, provided that each such delegation is in writing and a copy thereof is filed in the office of the Secretary; and it is

**FURTHER RESOLVED**, that any bond, recognizance, contract of indemnity, or writing obligatory in the nature of a bond, recognizance, or conditional undertaking shall be valid and binding upon the Company when (a) signed by the President, any Vice Chairman, any Executive Vice President, any Senior Vice President or any Vice President, any Second Vice President, the Treasurer, any Assistant Treasurer, the Corporate Secretary or any Assistant Secretary and duly attested and sealed with the Company's seal by a Secretary or Assistant Secretary; or (b) duly executed (under seal, if required) by one or more Attorneys-in-Fact and Agents pursuant to the power prescribed in his or her certificate or their certificates of authority or by one or more Company officers pursuant to a written delegation of authority; and it is

**FURTHER RESOLVED**, that the signature of each of the following officers: President, any Executive Vice President, any Senior Vice President, any Vice President, any Assistant Vice President, any Secretary, any Assistant Secretary, and the seal of the Company may be affixed by facsimile to any Power of Attorney or to any certificate relating thereto appointing Resident Vice Presidents, Resident Assistant Secretaries or Attorneys-in-Fact for purposes only of executing and attesting bonds and undertakings and other writings obligatory in the nature thereof, and any such Power of Attorney or certificate bearing such facsimile signature or facsimile seal shall be valid and binding upon the Company and any such power so executed and certified by such facsimile signature and facsimile seal shall be valid and binding on the Company in the future with respect to any bond or understanding to which it is attached.

I, **Kevin E. Hughes**, the undersigned, Assistant Secretary of Travelers Casualty and Surety Company of America, Travelers Casualty and Surety Company, and St. Paul Fire and Marine Insurance Company, do hereby certify that the above and foregoing is a true and correct copy of the Power of Attorney executed by said Companies, which remains in full force and effect.

Dated this \_\_\_\_\_ day of \_\_\_\_\_,



  
Kevin E. Hughes, Assistant Secretary

**To verify the authenticity of this Power of Attorney, please call us at 1-800-421-3880.  
Please refer to the above-named Attorney-in-Fact and the details of the bond to which this Power of Attorney is attached.**

**SECTION 00434 - LIST OF PROPOSED SUBCONTRACTORS**

BIDDER shall list all Proposed Subcontractors to be used on this project if they are awarded the contract.

SCOPE	SUBCONTRACTOR NAME, ADDRESS AND LICENSE #
Fencing	Royal Fence & Equipment 5500 NW 74th Ave, Miami, FL 33166
_____	_____
_____	_____
_____	_____
_____	_____
_____	_____

If, prior to Notice of the Award, the City or the Contractor has reasonable objection to and refuses to accept any Contractor, Supplier, person or organization listed, the BIDDER may, prior to Notice of Award, submit an acceptable substitute without an increase in their bid price.

END OF SECTION

**SECTION 00450 - BIDDER QUALIFICATION STATEMENT**

The BIDDER’s response to this questionnaire will be utilized as part of the City’s overall Bid Evaluation and Contractor selection.

The following minimum experience is required for this project:

- Bidder shall be a State of Florida Certified General Contractor or Miami-Dade County licensed Engineering Contractor with a Certificate of Competency issued by the Construction Trades Qualifying Board, having at least 5 years of experience operating under its current name.
- Successful completion, verifiable with references, of at least three (3) projects with similar canal or river/stream bank restoration including utilization of geotextile or geo-web material for erosion control performed in Florida with a total cost of more than five hundred thousand (\$500,000) dollars each within the past five (5) years.
- At least one (1) project similar in scope should have been performed for a governmental entity in Florida.
- Contractor must also have previous experience with general civil construction including asphalt paving, concrete work, fencing as well as earth movement using proper equipment on environmentally sensitive projects.
- Contractor must provide proof of personnel experience in performing the above referenced work, having the capability of working various sites simultaneously, and having a Project Manager with at least 5 years of experience on similar projects.

Failure to meet these minimum guidelines will be considered an unresponsive submittal and the documents will not be considered.

List projects experience consistent with the requirements stated.

1. Project Name:	Canal Bank Stabilization - Year 5A
Location:	Doral, FL
Project Description:	Canal embankment improvements project using geoweb to stabilize over 11,000 LF of bank, including demolition, excavation, installation of canal bank stabilization system (geoweb), grading, sodding, 10' wide asphalt path, and chain link fence.
Budget/Cost	\$2,002,370.00
Dates of Contract	06/2017 to 03/2018
Owner Name	City of Doral
Contact Person & Phone #	Ms. Stephanie Bortz, CFM / 305-593-6725 x6024



Contact email: stephanie.bortz@cityofdoral.com

2. Project Name: Canal Bank Stabilization - Year 5B

Location: Doral, FL

Project Description: Canal embankment improvements project using geoweb to stabilize 8,500 LF of bank as well as a combination of bedding stone and rip rap to stabilize about 2000 LF of bank, including demolition, excavation, installation of canal bank stabilization system (geoweb), grading, sodding, 10' wide asphalt path, and chain link fence.

Budget/Cost: \$3,201,215.24

Dates of Contract: 02/2019 to 01/2020

Owner Name: City of Doral

Contact Person & Phone #: Ms. Stephanie Bortz, CFM / 305-593-6725 x6024

Contact email: stephanie.bortz@cityofdoral.com

3. Project Name: C-4 Canal Bank Improvements - Palmetto Phase 2

Location: Miami, FL

Project Description: Canal embankment improvement project including demolition of existing structures within canal ROW, excavation/fill, grading, installation of high performance turf reinforcement mat, and drainage structures.

Budget/Cost: \$1,633,273.89

Dates of Contract: 05/2018 to 04/2019

Owner Name: South Florida Water Management District

Contact Person & Phone #: Mr. Jesse VanEyck, PE / 561-370-4859

Contact email: jvaneyk@sfwmd.gov

END OF SECTION



By: \_\_\_\_\_

*Isabella Micotta*  
Isabella Micotta

Print Name: Wilson Sanchez

The foregoing instrument was acknowledged before me, by means of  physical presence or  online notarization, this 20 day of July, 2020 (year), by Wilson Sanchez

Similarly, for an instrument requiring an oath or affirmation, the relevant portion of the statutory certificate should read as follows (the yellow-highlighted section is the new required language):

Sworn to (or affirmed) and subscribed before me, by means of  physical presence or  online notarization, this 20 day of July, 2020 (year), by Wilson Sanchez



**Nairim E. Armstrong**  
**Comm # GG952038**  
**Expires Jan. 28, 2024**  
**Bonded Thru Aaron Notary**

*Nairim E. Armstrong*  
\_\_\_\_\_  
Notary Public

State of Florida at Large

My Commission Expires: 01/28/2024

My Commission Number: GG952038

ACKNOWLEDGMENT

State of Florida

County of Florida

On this the 20 day of July, 2020, before me, the undersigned Notary Public of the State of Florida, personally appeared

Wilson Sanchez and Isabella Micolta  
(Name(s) of individual(s) who appeared before notary)

Whose name(s) is/are Subscribed to the within instrument, and he/she/they acknowledge that he/she/they executed it.

WITNESS in my hand and official seal.

  
\_\_\_\_\_  
NOTARY PUBLIC, STATE OF FLORIDA

NOTARY PUBLIC:  
SEAL OF OFFICE:



**Nairim E. Armstrong**  
**Comm # GG952038**  
**Expires Jan. 28, 2024**  
**Bonded Thru Aaron Notary**

Nairim Armstrong  
(Name of Notary Public: Print, Stamp, or Type as Commissioned)

- Personally known to me, or
- Personally identification:

\_\_\_\_\_  
(Type of Identification Produced)

- Did take an oath, or
- Did NOT take an oath,

OPTIONAL INFORMATION:

Type of Document \_\_\_\_\_ Number of Pages: \_\_\_\_\_  
Number of Signatures Notarized: \_\_\_\_\_

## **SECTION 00456 - PUBLIC ENTITY CRIMES**

Pursuant to the provisions of paragraph (2) (a) of Section 287.133, Florida State Statutes - "A person or affiliate who has been placed on the convicted vendor list following a conviction for a public entity crime may not submit a Bid on a Contract to provide any goods or services to a public entity, may not submit a Bid on a Contract with a public entity for the construction or repair of a public building or public Work, may not submit bids on leases of real property to a public entity, may not be awarded to perform Work as a Contractor, supplier, Subcontractor, or Contractor under a Contract with any public entity, and may not transact business with any public entity in excess of the threshold amount Category Two of Sec. 287.017, FS for thirty six months from the date of being placed on the convicted vendor list".

## **CONFLICTS OF INTEREST**

The award of any contract hereunder is subject to the provisions of Chapter 112, Florida State Statutes. BIDDER's must disclose with their Bids, the name of any officer, director, partner, associate or agent who is also an officer or employee of the City of Doral or its' agencies.

**SWORN STATEMENT PURSUANT TO SECTION 287.133(3)(a)  
FLORIDA STATUTES, ON PUBLIC ENTITY CRIMES**

**ITB No. 2020-23**

THIS FORM MUST BE SIGNED AND SWORN TO IN THE PRESENCE OF A NOTARY PUBLIC OR OTHER OFFICIAL AUTHORIZED TO ADMINISTER OATHS.

1. This sworn statement is submitted  
to City of Doral  
by Wilson Sanchez  
for ENCO, LLC  
whose business address  
is 5411 SW 25th Ct., Pembroke Park, FL 33023 and (if  
applicable) its Federal Employer Identification number (FEIN) is 01-0632027 (IF the entity  
had no FEIN, include the Social Security Number of the individual signing this sworn  
statement: N/A).

2. I understand that a "public entity crime" as defined in Paragraph 287.133(1)(g), Florida Statutes, means a violation of any state or federal law by a person with respect to and directly related to the transaction of business with any public entity or with an agency or political subdivision of any other state or with the United States, including, but not limited to, any Bid or Contract for goods or services to be provided to any public entity or an agency or political subdivision of any other state of the United States and involving antitrust, fraud, theft, bribery, collusion, racketeering, conspiracy, or material misrepresentation.

3. I understand that "convicted" or "conviction" as defined in Para. 287.133(1)(b), Florida Statutes, means a finding of guilt or a conviction of a public entity crime, with or without an adjudication of guilt, in any federal or state trial court of record relating to charges brought by indictment or information after July 1, 1989, as a result of a jury verdict, non-jury trial, or entry of a plea of guilty or nolo contendere.

4. I understand that an "affiliate" as defined in Para. 287.133(1)(a), Florida Statutes, means:

1. A predecessor or successor of a person convicted of a public entity crime; or
2. Any entity under the control of any natural person who is active in the management of the entity and who has been convicted of a public entity crime. The term "affiliate" includes those officers, directors, executors, partners, shareholders, employees, members, and agents who are active in the management of an affiliate. The ownership by one person of shares constituting a controlling interest in another person, or a pooling of equipment or income among persons when not for fair market value under an arm's length agreement, shall be a prime facie case that one person controls another person. A person who knowingly enters into a joint venture with a person who has been convicted of a public entity crime in Florida during the preceding 36 months shall be considered an affiliate.

5. I understand that a "person" as defined in Para. 287.133(1)(e), Florida Statutes, means any natural person or entity organized under the laws of any state or of the United States with the legal power to enter into a binding Contract and which Bids or applies to Bid on Contracts for the provision of goods or services let by a public entity, or which otherwise transacts or applies to transact business with a public entity. The term "persons" includes those officers, directors, executives, partners, shareholders, employees, members, and agents who are active in management of any entity.

6. Based on information and belief, the statement which I have marked below is true in relation to the entity submitting this sworn statement. (Indicate which statement applies.)

N/A Neither the entity submitting this sworn statement, nor any of its officers, directors, executives, partners, shareholders, employees, members, or agents who are active in the management of the entity, nor any affiliate of the entity has been charged with and convicted of a public entity crime subsequent to July 1, 1989.

N/A The entity submitting this sworn statement, or one or more of its officers, directors, executives, partners, shareholders, employees, members, or agents who are active in the management of the entity, or an affiliate of the entity has been charged with and convicted of a public entity crime subsequent to July 1, 1989.

N/A The entity submitting this sworn statement, or one or more of its officers, directors, executives, partners, shareholders, employees, members, or agents who are active in the management of the entity, or an affiliate of the entity has been charged with and convicted of a public entity crime subsequent to July 1, 1989. However, there has been a subsequent proceeding before a Hearing Officer of the State of Florida, Division of Administrative Hearings and the Final Order entered by the Hearing Officer of the State of Florida, Division of Administrative Hearings and the Final Order entered by the Hearing Officer determined that it was not in the public interest to place the entity submitting this sworn statement on the convicted vendor list. (Attach a copy of the final order.)

I UNDERSTAND THAT THE SUBMISSION OF THIS FORM TO THE CONTRACTING OFFICER FOR THE PUBLIC ENTITY IDENTIFIED IN PARAGRAPH 1 (ONE) ABOVE IS FOR THAT PUBLIC ENTITY ONLY AND, THAT THIS FORM IS VALID THROUGH DECEMBER 31 OF THE CALENDAR YEAR IN WHICH IT IS FILED. I ALSO UNDERSTAND THAT I AM REQUIRED TO INFORM THE PUBLIC ENTITY PRIOR TO ENTERING INTO A CONTRACT IN EXCESS OF THE THRESHOLD AMOUNT PROVIDED IN SECTION 287.017, FLORIDA STATUTES, FOR CATEGORY TWO OF ANY, CHANGE IN THE INFORMATION CONTAINED IN THIS FORM.

By: 

(Printed Name) Wilson Sanchez

(Title) Managing Member

The foregoing instrument was acknowledged before me, by means of  physical presence or  online notarization, this 20 day of July, 2020 (year), by Wilson Sanchez

Similarly, for an instrument requiring an oath or affirmation, the relevant portion of the statutory certificate should read as follows (the yellow-highlighted section is the new required language):

Sworn to (or affirmed) and subscribed before me, by means of  physical presence or  online notarization, this 20 day of July, 2020 (year), by Wilson Sanchez

Personally known X

Or Produced Identification \_\_\_\_\_

Notary Public - State of Florida

My Commission Expires Jan. 28, 2024

 Nairim Armstrong  
(Type of Identification) (Printed, typed, or stamped commission name of notary public)



**Nairim E. Armstrong**  
**Comm # GG952038**  
**Expires Jan. 28, 2024**  
**Bonded Thru Aaron Notary**

N/A

## STATEMENT OF NO RESPONSE

### ITB No. 2020-23

If you are not proposing on this service/commodity, please complete and return this form to: City of Doral – City Manager’s Office 8401 NW 53<sup>rd</sup> Terrace Doral, FL 33166. Failure to respond may result in deletion of your firm’s name from the qualified vendor list for the City of Doral.

COMPLANY NAME: \_\_\_\_\_

ADDRESS: \_\_\_\_\_

TELEPONE: \_\_\_\_\_

SIGNATURE: \_\_\_\_\_

DATE: \_\_\_\_\_

We, the undersigned have declined to submit a proposal on the above because of the following reasons:

- \_\_\_\_\_ Specifications/Scope of Work too “tight”, i.e., geared toward brand or manufacturer only (explain below).
- \_\_\_\_\_ Insufficient time to respond.
- \_\_\_\_\_ We do not offer this product, service or an equivalent.
- \_\_\_\_\_ Our schedule would not permit us to perform.
- \_\_\_\_\_ Unable to meet bond requirements.
- \_\_\_\_\_ Specifications unclear (explain below).
- \_\_\_\_\_ Other (specify below).

REMARKS: \_\_\_\_\_

\_\_\_\_\_

For bidders submitting proposals for this opportunity, you may write “N/A” on this form.



SOLICITATION RESPONSE FORM

**BIDDERS MUST ATTACH THIS FORM TO THE EXTERIOR OF THE SEALED PACKET**

Name: "ITB No. 2020-23 Canal Bank Stabilization Program: Year 5A Phase II"

Due Date: July 23<sup>rd</sup>, 2020 at 10:00 am

Delivery Location: CITY OF DORAL  
CITY CLERK'S OFFICE  
8401 NW 53<sup>RD</sup> TERRACE  
DORAL, FL 33166

Submitted By: ENCO, LLC  
(Name of company and address) \_\_\_\_\_  
  
5411 SW 25th Ct \_\_\_\_\_  
  
Pembroke Park, FL 33023 \_\_\_\_\_

PLEASE DO NOT TAPE BELOW THIS LINE

---

**For Office Use Only:**

Date and Time Received:

Received by: \_\_\_\_\_

**GENERAL INFORMATION WORKSHEET**  
**ITB No. 2020-23**

ORGANIZATION/AGANCY/FIRM/NAME: ENCO, LLC

DATE ORGANIZATION WAS FORMED/INCORPORATED: March 7, 2002

FEDERAL TAX ID NUMBER: 01-0632027

MAILING ADDRESS: 5411 SW 25th Ct., Pembroke Park, FL 33023

PHONE NUMBER: 954-342-2466

ORGANIZATION EMAIL ADDRESS: wsanchez@encollc.com

ORGANIZATION WEBISTE ADDRESS: www.encollc.com

CONTACT PERSON & TITLE: Wilson Sanchez / Managing Member

CONTACT EMAIL ADDRESS: wsanchez@encollc.com PHONE No: 954-342-2466

INDIVIDUAL(S) AUTHORIZED TO MAKE REPRESENTATION FOR THE CONTRACTOR:

<u>Wilson Sanchez</u> (First, Last Name)	<u>Managing Member</u> (Title)	<u>954-342-2466</u> (Contact Phone Num.)
---	-----------------------------------	---

<u>Lucio Micolta</u> (First, Last Name)	<u>Managing Member</u> (Title)	<u>954-342-2466</u> (Contact Phone Num.)
--	-----------------------------------	---

_____ (First, Last Name)	_____ (Title)	_____ (Contact Phone Num.)
-----------------------------	------------------	-------------------------------

ADDITIONAL INFORMATION

\_\_\_\_\_

CONTACT'S SIGNATURE:  DATE: 07/20/2020

**BUSINESS ENTITY AFFIDAVIT**  
**(VENDOR / BIDDER DISCLOSURE)**  
**ITB No. 2020-23**

I, Wilson Sanchez, being first duly sworn state:

The full legal name and business address of the person(s) or entity contracting or transacting business with the City of Doral ("City") are (Post Office addresses are not acceptable), as follows:

01-0632027

FEDERAL EMPLOYER IDENTIFICATION NUMBER (IF NONE, SOCIAL SECURITY NUMBER)

ENCO, LLC

Name of Entity, Individual, Partners, or Corporation

Doing business as, if same as above, leave blank

5411 SW 25th Ct

Pembroke Park

FL

33023

STREET ADDRESS

SUITE

CITY

STATE

ZIP CODE

**OWNERSHIP DISCLOSURE AFFIDAVIT**

1. If the contact or business transaction is with a corporation, the full legal name and business address shall be provided for each officer and director and each stockholder who holds directly or indirectly five percent (5%) or more of the corporation's stock. If the contract or business transaction is with a trust, the full legal name and address shall be provided for each trustee and each beneficiary. All such names and addresses are (Post Office addresses are not acceptable), as follows:

<u>Full Legal Name</u>	<u>Address</u>	<u>Ownership</u>
<u>Wilson Sanchez</u>	<u>5315 Roosevelt St., Hollywood, FL 33021</u>	<u>50</u> %
<u>Lucio Micolta</u>	<u>483 Talavera Rd, Weston, FL 33326</u>	<u>50</u> %
		%

2. The full legal names and business address of any other individual (other than subcontractors, material men, suppliers, laborers, or lenders) who have, or will have, any interest (legal, equitable, beneficial or otherwise) in the contract or business transaction with the City are (Post Office addresses are not acceptable), as follows:

\_\_\_\_\_  
\_\_\_\_\_  
\_\_\_\_\_

*[Handwritten signature]*

07/20/2020

Signature of Affiant

Date

Wilson Sanchez

Printed Name of Affiant

The foregoing instrument was acknowledged before me, by means of  physical presence or  online notarization, this 20 day of July, 2020 (year), by Wilson Sanchez

Similarly, for an instrument requiring an oath or affirmation, the relevant portion of the statutory certificate should read as follows (the yellow-highlighted section is the new required language):

Sworn to (or affirmed) and subscribed before me, by means of  physical presence or  online notarization, this 20 day of July, 2020 (year), by Wilson Sanchez

Personally known x

OR

Produced identification \_\_\_\_\_

Notary Public-State of Florida

My commission expires: Jan 28, 2024

Type of Identification

*[Handwritten signature]* Nairim Armstrong  
Printed, typed, or stamped commissioned name of Notary Public



**Nairim E. Armstrong**  
**Comm # GG952038**  
**Expires Jan. 28, 2024**  
**Bonded Thru Aaron Notary**

**NO CONTINGENCY AFFIDAVIT  
ITB No. 2020-23**

State of Florida )  
 ) SS  
County of Broward )

**BEFORE ME**, the undersigned authority, personally appeared Wilson Sanchez, who, after being duly sworn, deposes and states that all of the facts herein are true:

- (1) He/She/They is/are Managing Member Owner, Partner, Officer, Representative or Agent) of ENCO, LLC, the BIDDER that has submitted the attached Bid;
- (2) Bidder warrants that neither it, nor any principal, employee, agent, representative or family member has promised to pay, and Firm has not, and will not; pay a fee the amount of which is contingent upon the City of Doral awarding this contract. Firm warrants that neither it, nor any principal, employee, agent, representative has procured, or attempted to procure, this contract in violation of any of the provisions of the Miami-Dade County conflict of interest and code of ethics ordinances; and
- (3) Further, Firm acknowledges that a violation of this warranty may result in the termination of the contract and forfeiture of funds paid, or to be paid, to the Firm, if the Firm is chosen for performance of the contract.

FURTHER AFFIANT SAYETH NOT

  
By: \_\_\_\_\_  
Print Name: Wilson Sanchez

SWORN TO AND SUBSCRIBED before me this 20 day of July, 2020 by  
X \_\_\_\_\_, who is personally known to me or has produced  
\_\_\_\_\_ as identification.

  
\_\_\_\_\_  
Notary Public

State of Florida at Large  
**Nairim E. Armstrong**  
**Comm # GG952038**  
**Expires Jan. 28, 2024**  
**Bonded Thru Aaron Notary**

My Commission Expires:  
My Commission Number:



**AMERICANS WITH DISABILITIES ACT (ADA)  
DISABILITY NONDISCRIMINATION STATEMENT**

**ITB No. 2020-23**

THIS FORM MUST BE SIGNED AND SWORN TO IN THE PRESENCE OF A NOTARY PUBLIC OR OTHER  
OFFICIAL AUTHORIZED TO ADMINISTER OATHS.

This sworn statement is submitted to the City Of Doral, Florida

by: Wilson Sanchez  
(print individual's name and title)

for: ENCO, LLC  
(print name of entity submitting sworn statement)

whose business address is: 5411 SW 25th Ct, Pembroke Park, FL 33023

and (if applicable) its Federal Employer Number (FEIN) is: 01-0632027  
(If the entity has no FEIN, include the Social Security Number of the individual signing this sworn  
statement: \_\_\_\_\_ - \_\_\_\_\_ - \_\_\_\_\_.)

I, being duly first sworn state:

That the above-named firm, corporation or organization is in compliance with and agreed to continue to comply with, and assure that any subcontractor, or third party contractor under this project complies with all applicable requirements of the laws listed below including, but not limited to, those provisions pertaining to employment, provision of programs and services, transportation, communications, access to facilities, renovations, and new construction.

The American with Disabilities Act of 1990 (ADA), Pub. L. 101-336, 104 Stat 327, 42 USC 12101-12213 and 47 USC Sections 225 and 661 including Title I, Employment; Title II, Public Services; Title III, Public Accommodations and Services Operated by Private entities; Title IV, Telecommunications; and Title V, Miscellaneous Provisions.

The Florida Americans with Disabilities Accessibility Implementation Act of 1993, Section 553.501-553.513, Florida Statutes:

The Rehabilitation Act of 1973, 29 USC Section 794;  
The Federal Transit Act, as amended 49 USC Section 1612;  
The Fair Housing Act as amended 42 USC Section 3601-3631.

\_\_\_\_\_  
SIGNATURE

The foregoing instrument was acknowledged before me, by means of  physical presence or  online notarization, this 20 day of July, 2020 (year), by Wilson Sanchez

Similarly, for an instrument requiring an oath or affirmation, the relevant portion of the statutory certificate should read as follows (the yellow-highlighted section is the new required language):

Sworn to (or affirmed) and subscribed before me, by means of  physical presence or  online notarization, this 20 day of July, 2020 (year), by Wilson Sanchez

Personally known x  
OR  
Produced Identification \_\_\_\_\_

Notary Public- State of Florida

My commission expires: Jan 28, 2024

Nairim E. Armstrong Nairim Armstrong  
Printed, typed, or stamped commissioned name of Notary Public



**Nairim E. Armstrong**  
**Comm # GG952038**  
**Expires Jan. 28, 2024**  
**Bonded Thru Aaron Notary**

**DRUG-FREE WORKPLACE PROGRAM**  
**ITB No. 2020-23**

The undersigned firm in accordance with Florida statute 287.087 hereby certifies that

ENCO, LLC

does:

*(Name of Firm)*

1. Publish a statement notifying employees that the unlawful manufacture, distribution, dispensing, possession, or use of a controlled substance is prohibited in the workplace and specifying the actions that will be taken against employees for violations of such prohibition.
2. Inform Employees about the dangers of drug abuse in the workplace, the business' policy of maintaining drug-free workplace, any available drug counseling, rehabilitation, and employee assistance programs, and the penalties that may be imposed upon employees for drug abuse violations.
3. Give each employee engaged in providing the commodities or contractual services that are under bid a copy of the statement specified in subsection (1).
4. In the statement specified in subsection (1), notify the employees that, as a conditions of working on the commodities or contractual services that are under bid, the employee will abide by the terms of the statement and will notify the employer of any conviction of, or plea of guilty or nolo contendere to, any violation of chapter 893 or of any controlled substance law of the United States or any state, for a violation occurring in the workplace no later than five (5) days after such conviction.
5. Impose a sanction on, or require the satisfactory participation in a drug abuse assistance or rehabilitation program if such is available in the employee's community, by any employee who is so convicted.
6. Make good faith effort to continue to maintain a drug-free workplace through implementation of this section.

As the person authorized to sign the statement, I certify that this firm complies fully with the above requirements.

Wilson Sanchez / Managing Member

Name and Title

07/20/2020

Date

Signature

ENCO, LLC

Firm

5411 SW 25th Ct., Pembroke Park, FL 33023

Street address

City, State, Zip



**COPELAND ACT ANTI-KICKBACK AFFIDAVIT**

**ITB No. 2020-23**

STATE OF Florida }

}SS:

COUNTY OF Broward }

I, the undersigned, hereby duly sworn, depose and say that no portion of the sum herein bid will be paid to any employees of the City of Doral, its elected officials, and \_\_\_\_\_ or its design consultants, as a commission, kickback, reward or gift, directly or indirectly by me or any member of my firm or by an officer of the corporation.

By:   
\_\_\_\_\_ Wilson Sanchez

Title: Managing Member

Sworn and subscribed before this

20 day of July, 2020

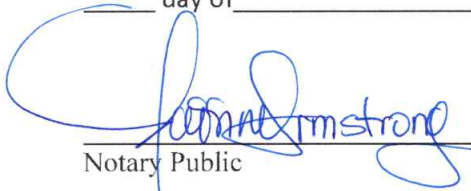
  
\_\_\_\_\_  
Notary Public

Nairim Armstrong  
\_\_\_\_\_  
(Printed Name)

My commission expires: Jan 28, 2024



**Nairim E. Armstrong**  
**Comm # GG952038**  
**Expires Jan. 28, 2024**  
**Bonded Thru Aaron Notary**

**CONE OF SILENCE CERTIFICATION  
ITB No. 2020-23**

I, Wilson Sanchez, Managing Member  
(Individual's Name) (Title)

of the ENCO, LLC, do hereby certify  
that (Name of Company)

I have read and understand the terms set forth under section 1.11 of this document titled 'Cone of Silence'.

Attachment of this executed form, as such, is required to complete a valid bid.



Individual's Signature Wilson Sanchez

07/20/2020

**EQUAL EMPLOYMENT OPPORTUNITY CERTIFICATION**

**ITB No. 2020-23**

I, Wilson Sanchez, Managing Member  
(Individual's Name) (Title)

of the ENCO, LLC, do hereby certify  
that (Name of Company)

I have read and understand the Compliance with Equal Employment Opportunity requirements set forth under sub-section 2.17.3 of this document.

Attachment of this executed form, as such, is required to complete a valid bid.



Individual's Signature Wilson Sanchez

07/20/2020

Date

**RESPONDENT'S CERTIFICATION**  
**ITB No. 2020-23**

I have carefully examined the Invitation to Bid, Instructions to Respondents, General and/or Special Conditions, Vendor's Notes, Specifications, proposed agreement and any other documents accompanying or made a part of this Invitation to Bids.

I hereby propose to furnish the goods or services specified in the ITB. I agree that my Proposal will remain firm for a period of 365 days in order to allow the City adequate time to evaluate the Proposals.

I certify that all information contained in this Proposal is truthful to the best of my knowledge and belief. I further certify that I am duly authorized to submit this proposal on behalf of the firm as its act and deed and that the firm is ready, willing and able to perform if awarded the contract.

I further certify, under oath, that this proposal is made without prior understanding, agreement, connection, discussion, or collusion with any other person, firm or corporation submitting a Proposal for the same product or service; no officer, employee or agent of the City of Doral or any other Respondent is interested in said Respondent; and that the undersigned executed this Respondent's Certification with full knowledge and understanding of the matters therein contained and was duly authorized to do so.

A person or affiliate who has been placed on the convicted vendor list following a conviction for public entity crimes may not submit a proposal on a contract to provide any goods or services to a public entity, may not submit a bid on a contract with a public entity for the construction or repair of a public building or public work, may not submit bids on leases of real property to public entity, may not be awarded or perform work as a contractor, supplier, sub-contractor, or consultant under a contract with a public entity, and may not transact business with any public entity in excess of the threshold amount provided in Sec. 287.017, for CATEGORY TWO for a period of 36 months from the date of being placed on the convicted vendor list.

ENCO, LLC

Name of Business

The foregoing instrument was acknowledged before me, by means of  physical presence or  online notarization, this 20 day of July, 2020 (year), by Wilson Sanchez

Similarly, for an instrument requiring an oath or affirmation, the relevant portion of the statutory certificate should read as follows (the yellow-highlighted section is the new required language):

Sworn to (or affirmed) and subscribed before me, by means of  physical presence or  online notarization, this 20 day of July, 2020 (year), by Wilson Sanchez

Signature

Wilson Sanchez / Managing Member

Name and Title, Typed or Printed

5411 SW 25th Ct.

Mailing Address

Pembroke Park, FL 33023

City, State and Zip Code

954-342-2466

Telephone Number

Notary Public

Nairim Armstrong

STATE OF

Florida

My Commission Expires

111



**Nairim E. Armstrong**  
**Comm # GG952038**  
**Expires Jan. 28, 2024**  
**Bonded Thru Aaron Notary**

N/A

**ITB SIGNATURE PAGE FOR SOLE PROPRIETOR OR PARTNERSHIP  
ITB No. 2020-23**

The full names and residences of person, partners or firms interested in the foregoing ITB, as principals are as follows:

---

---

---

---

---

---

---

---

Witness:  
(Seal)

Bidder:

\_\_\_\_\_  
Witness Signature

\_\_\_\_\_  
Firm Name

\_\_\_\_\_  
Witness Name

\_\_\_\_\_  
Signature

\_\_\_\_\_  
Print Name

\_\_\_\_\_  
Title (Sole Proprietor or Partner)

Post Office Address:

---

---

County in which fictitious name is registered.

\_\_\_\_\_  
Telephone Num.

---

## ITB SIGNATURE PAGE FOR CORPORATION

**ITB No. 2020-23**

The officers of the corporation are as follows:

	<u>Name</u>	<u>Address</u>
President	Wilson Sanchez	5315 Roosevelt St., Hollywood, FL 33021
Vice-President	Lucio Micolta	483 Talavera Rd, Weston, FL 33326
Secretary	Isabella Micolta	3000 NE 188th St, #502, Aventura, FL 33180
Treasurer	Wilson Sanchez	5315 Roosevelt St., Hollywood, FL 33021
Registered Agent		

The full names and residences of stockholders, persons, or firms interested in the foregoing ITB, as principals, are as follows:

Wilson Sanchez	5315 Roosevelt St Hollywood, FL 33021	50%
Lucio Micolta	483 Talavera Rd Weston, FL 33326	50%

Post Office Address

5411 SW 25th Ct

Pembroke Park, FL 33023

Is this corporation in the State of Florida?

Yes  No

If no, give address of principle place of business:

Bidder

ENCO, LLC

Corporate Name

President's Signature Wilson Sanchez

Attest:

Secretary Isabella Micolta

N/A



# City of Doral

ITB No. 2020-23

## Canal Bank Stabilization Program: Year 5A Phase II

### Addendum No. 1

#### ATTENTION:

**The bid due date has been extended to Thursday, July 30<sup>th</sup>, 2020 at 10:00 A.M.**

Below are questions/ clarifications that were received regarding this project as well as the City's responses. This Addendum is and does become a part of the above-mentioned solicitation. This addendum is issued to modify the subject solicitation as follows:

1. Provide the engineers estimate or budget amount for this project?
    - Estimate - \$657,351.50
    - Budget - \$774,099.06
  2. Do you have a spec package that you can provide for the Canal Bank Stabilization Program: Year 5A Phase II?
    - Yes, see attached technical specs as well as the Geotechnical report.
  3. On Section 00450 - Bidder Qualification Statement (pg.33), the minimum experience required includes road widening, road reconstruction, and stormwater drainage improvements. However, the scope of the project is described as "restore and stabilize canal banks for various sections of the Dressels Canal" (pg.3). (As a side note, ITB 2020-24 has the same qualifications and that project does include road reconstruction/stormwater drainage).
    - Please see attached amended Section 00450 – Bidder Qualification Statement.
- Please see attached revised draft contract to reflect the correct Term of Contract.

Acknowledged: Wilson Sanchez

## SECTION 00450 - BIDDER QUALIFICATION STATEMENT

The BIDDER's response to this questionnaire will be utilized as part of the City's overall Bid Evaluation and Contractor selection.

The following minimum experience is required for this project:

- Bidder shall be a State of Florida Certified General Contractor or Miami-Dade County licensed Engineering Contractor with a Certificate of Competency issued by the Construction Trades Qualifying Board, having at least 5 years of experience operating under its current name.
- Successful completion, verifiable with references, of at least three (3) projects with similar canal or river/stream bank restoration including utilization of geotextile or geo-web material for erosion control performed in Florida with a total cost of more than five hundred thousand (\$500,000) dollars each within the past five (5) years.
- At least one (1) project similar in scope should have been performed for a governmental entity in Florida.
- Contractor must also have previous experience with general civil construction including asphalt paving, concrete work, fencing as well as earth movement using proper equipment on environmentally sensitive projects.
- Contractor must provide proof of personnel experience in performing the above referenced work, having the capability of working various sites simultaneously, and having a Project Manager with at least 5 years of experience on similar projects.

Failure to meet these minimum guidelines will be considered an unresponsive submittal and the documents will not be considered.

List projects experience consistent with the requirements stated.

1. Project Name:	_____
Location:	_____
Project Description:	_____ _____ _____ _____
Budget/Cost	_____
Dates of Contract	_____
Owner Name	_____
Contact Person & Phone #	_____



Contact email: \_\_\_\_\_

2. Project Name: \_\_\_\_\_

Location: \_\_\_\_\_

Project Description: \_\_\_\_\_

\_\_\_\_\_

\_\_\_\_\_

Budget/Cost \_\_\_\_\_

Dates of Contract \_\_\_\_\_

Owner Name \_\_\_\_\_

Contact Person & Phone # \_\_\_\_\_

Contact email: \_\_\_\_\_

3. Project Name: \_\_\_\_\_

Location: \_\_\_\_\_

Project Description: \_\_\_\_\_

\_\_\_\_\_

\_\_\_\_\_

Budget/Cost \_\_\_\_\_

Dates of Contract \_\_\_\_\_

Owner Name \_\_\_\_\_

Contact Person & Phone # \_\_\_\_\_

Contact email: \_\_\_\_\_

END OF SECTION

## SECTION 00500 - CONSTRUCTION CONTRACT

This Contract (the "Contract") is dated as of the \_\_\_\_\_ day of \_\_\_\_\_ 20\_\_ by and between the City of Doral (hereinafter called the "CITY") and \_\_\_\_\_ (hereinafter called "CONTRACTOR") located at: \_\_\_\_\_.

CITY and CONTRACTOR, in consideration of the mutual covenants hereinafter set forth, agree as follows:

### **ARTICLE 1 – WORK**

1.1 Project/Work: CONTRACTOR shall complete all Work as specified or indicated in the Contract Documents. The Work is generally described as the following: The Project consists of **Canal Bank Stabilization Program: Year 5A Phase II, ITB No.2020-23** all in accordance with the construction drawings.

### **ARTICLE 2 – CITY'S REPRESENTATIVE, ARCHITECT AND ENGINEER**

2.1 It is understood that the CITY will designate a representative for the Work. The CITY'S REPRESENTATIVE referred to in any of the Contract Documents designated herein is **Carlos Arroyo, Public Works Director**, at City of Doral Government Center, 8401 NW 53<sup>rd</sup> Terrace Doral, Florida 33166.

2.2 The CITY's ARCHITECT referred to in any of the Contract Documents designated herein is \_\_\_\_\_ N/A \_\_\_\_\_, \_\_\_\_\_ N/A \_\_\_\_\_.

2.3 The CITY's ENGINEER referred to in any of the Contract Documents designated is **Carlos Ortega, P.E.**, at ADA Engineering, Inc., 8550 NW 33 Street, Doral, Florida 33122.

### **ARTICLE 3 – TERM**

3.1 Contract Times. Contract Time will commence on the date the Agreement is executed and shall continue consequently for a period of **one hundred and twenty (120) calendar days**. Work shall be completed ("Final Completion") and shall be ready for final payment in accordance with the Contract Documents within thirty (30) calendar days from the date substantial completion is accepted

3.2 Term. This Contract shall not be effective until it is fully executed between the CITY and the CONTRACTOR. The term of the Contract shall be through the date of final payment unless terminated earlier pursuant to Section 00710 – General Conditions, Article 12, Suspension of Work and Termination.

3.3 Survival of Obligations. Any obligations by the CONTRACTOR, including but not limited to those set forth in Section 00710 – General Conditions, Article 13, Contractor's General Warranty and Guarantee, that would or could occur after the date of expiration or termination of the Contract shall survive the termination or expiration of the Contract.

**3.4** Liquidated Damages. CITY and CONTRACTOR recognize that time is of the essence in this Contract and that the CITY will suffer financial loss if the Work is not completed within the contract times specified in Section 3.1 for the Work above, plus any approved extensions thereof allowed in accordance with the General Conditions. The CONTRACTOR also recognizes the delays, expense and difficulties involved in proving the actual loss suffered by CITY if the Work is not completed on time. Accordingly, instead of requiring any such proof, CITY and CONTRACTOR agree that as liquidated damages for delay (but not as a penalty) CONTRACTOR shall pay CITY **\$2,000.00** for each calendar day that expires after the time specified in Section 3.1 for Substantial Completion of the Work. After Final Completion, if CONTRACTOR shall neglect, refuse or fail to complete the remaining Work within the time specified in Section 3.1 for completion and readiness for final payment or any proper extension thereof granted by CITY, CONTRACTOR shall pay CITY **\$2,000.00** for each calendar day that expires after the time specified in Section 3.1 for completion and readiness for final payment.

**3.5** Should the Final Completion and acceptance of Work, together with any modification or additions, be delayed beyond the time for performance set in Section 3.1 above because of lack of performance by the CONTRACTOR, it is understood and agreed that aside from any other liquidated damages, all actual additional costs or losses incurred by the CITY including, but not limited to, completion contractor services, financing, professional services, unrealized revenue, will be the responsibility of the CONTRACTOR.

**3.6** Monies due to the CITY under Sections 3.4 and 3.5 shall be deducted from any monies due the CONTRACTOR, or if no money is due or the amount due is insufficient to cover the amount charged the CONTRACTOR shall be liable for said amount.

#### **ARTICLE 4 – CONTRACT PRICE**

**4.1** CITY shall pay CONTRACTOR for completion of the Work in accordance with the Contract Documents an amount in current funds equal to the sum of the amounts determined pursuant to this Article.

**4.1.1** For all Unit Price Work, an amount equal to the sum of the established unit price for each separately identified item of Unit Price Work times the estimated quantity of that item as indicated on the Unit Price Bid Form Section 00410. Estimated quantities are not guaranteed, and determination of actual quantities and classification are to be made by ENGINEER as provided in the Contract Documents.

**4.2** The CONTRACTOR agrees that all specific cash allowances are included in the above Contract Price and have been computed in accordance with the Contract Documents.

#### **ARTICLE 5 – PAYMENT PROCEDURES**

**5.1** CONTRACTOR shall submit Applications for Payment in accordance with the Section 00710 - General Conditions, Article 11, Payments to Contractor and Completion. Applications for Payment will be processed by CITY as provided in the General Conditions.

**5.2** Progress Payments, Retainage. CITY shall make progress payments, deducting the amount from the Contract Price above, on the basis of CONTRACTOR'S Applications for Payment as recommended by the CITY'S REPRESENTATIVE, on or about the last day of each month during

construction as provided herein. All such payments will be made in accordance with the schedule of values established in the General Conditions or, in the event there is no schedule of values, as provided in the General Conditions.

**5.2.1** No progress payment shall be made until CONTRACTOR delivers to the CITY complete original partial releases of all liens and claims signed by all Subcontractors, materialmen, suppliers, and vendors, indicating amount of partial payment, on a form approved by the CITY, and an affidavit that so far as the CONTRACTOR has knowledge or information, the releases include and cover all Materials and Work for which a lien or claim could be filed for work completed to date. CONTRACTOR shall also include red-line as-builts and an updated progress schedule.

**5.3** The CONTRACTOR agrees that ten percent (10%) of the amount due for Work as set forth in each Application for Payment shall be retained by CITY for each Progress Payment until Final Payment, as defined in Section 00710 - General Conditions, Article 11, Payments to Contractor and Completion.

**5.3.1** Prior to Substantial Completion, progress payments will be made in an amount equal to the percentage indicated above, but, in each case, less the aggregate of payments previously made and less such amounts as CITY'S REPRESENTATIVE shall determine, or CITY may withhold, in accordance with the General Conditions.

**5.4** The payment of any Application for Payment by CITY, including the Final Request, does not constitute approval or acceptance by CITY of any item of the Work in such Request for Payment, nor shall it be construed as a waiver of any of CITY's rights hereunder or at law or in equity.

**5.5** The Final Application for Payment by CONTRACTOR shall not be made until the CONTRACTOR delivers to the CITY complete original releases of all liens and claims signed by all Subcontractors, materialmen, suppliers, and vendors on a form approved by the CITY, and an affidavit that so far as the CONTRACTOR has knowledge or information, the releases include and cover all Materials and Work for which a lien or claim could be filed. The CONTRACTOR may, if any Subcontractor, materialmen, supplier or vendor refuses to furnish the required Final Waiver of Lien, furnish a bond satisfactory to CITY to defend and indemnify CITY and any other property owner, person or entity CITY may be required to indemnify against any lien or claim.

**5.6** Final Payment. Upon final completion and acceptance of the Work in accordance with the General Conditions, CITY shall pay the remainder of the Contract Price and any retainage as recommended by the CITY'S REPRESENTATIVE.

**ARTICLE 6 – INSURANCE/INDEMNIFICATION.**

**6.1** Insurance. The CONTRACTOR shall secure and maintain throughout the duration of this Contract, insurance of such type and in such amounts necessary to protect its interest and the interest of the CITY against hazards or risks of loss as specified in the General Conditions of the Contract Documents.

**6.2** Indemnification. The CONTRACTOR shall indemnify, defend and hold harmless the CITY, their officials, agents, employees, and volunteers as set forth in General Conditions of the Contract Documents.

**ARTICLE 7 – CONTRACTOR’S REPRESENTATIONS.**

In order to induce CITY to enter into this Contract, CONTRACTOR makes the following representations:

**7.1** CONTRACTOR has examined and carefully studied the Contract Documents (including the Addenda) and the other related data identified in the Bidding Documents including “technical data.”

**7.2** CONTRACTOR has visited the site and become familiar with and is satisfied as to the general, local and site conditions that may affect cost, progress, performance or furnishing of the Work.

**7.3** CONTRACTOR is familiar with and is satisfied as to all federal, state and local Laws and Regulations that may affect cost, progress, performance and furnishing of the Work.

**7.4** CONTRACTOR has made, or caused to be made, examinations, investigations, tests, or studies as necessary to determine surface and subsurface conditions at or on the site. CONTRACTOR acknowledges that CITY does not assume responsibility for the accuracy or completeness of information and data shown or indicated in the Contract Documents with respect to underground facilities at or contiguous to the site. CONTRACTOR has obtained and carefully studied (or assumes responsibility for having done so) all such additional supplementary examinations, investigations, explorations, tests, studies and data concerning conditions (surface, subsurface and Underground Facilities) at or contiguous to the site or otherwise which may affect cost, progress, performance or furnishing of the Work or which relate to any aspect of the means, methods, techniques, sequences and procedures of construction to be employed by CONTRACTOR and safety precautions and programs incident thereto. CONTRACTOR does not consider that any additional examinations, investigations, explorations, tests, studies or data are necessary for the performance and furnishing of the Work at the Contract Price, within the Contract Times and in accordance with the other terms and conditions of the Contract Documents.

**7.5** The CONTRACTOR is aware of the general nature of Work to be performed by CITY and others at the site that relates to the Work as indicated in the Contract Documents.

**7.6** The CONTRACTOR has correlated the information known to CONTRACTOR, information and observations obtained from visits to the site, reports and drawings identified in the Contract Documents and all additional examinations, investigations, explorations, tests, studies and data with the Contract Documents.

**7.7** The CONTRACTOR has given the CITY’S REPRESENTATIVE written notice of all conflicts, errors, ambiguities or discrepancies that CONTRACTOR has discovered in the Contract Documents and the written resolution thereof by the CITY’S REPRESENTATIVE is acceptable to CONTRACTOR, and the Contract Documents are generally sufficient to indicate and convey understanding of all terms and conditions for performance and furnishing of the Work.

**7.8** The CONTRACTOR warrants the following:

**7.8.1 Anti-Discrimination:** The CONTRACTOR agrees that it will not discriminate against any employees or applicants for employment or against persons for any other benefit or service under this Contract because of race, color, religion, sex, national origin, or physical or mental handicap where the handicap does not affect the ability of an individual to perform in a position of employment, and to abide by all federal and state laws regarding non-discrimination.

**7.8.2 Anti-Kickback:** The CONTRACTOR warrants that no person has been employed or retained to solicit or secure this Contract upon an agreement or understanding for a commission, percentage, brokerage or contingent fee, and that no employee or officer of the CITY or any other applicable federal or state agency, has any interest, financially or otherwise, in the Project. For breach or violation of this warranty, the CITY shall have the right to annul this Contract without liability or, in its discretion, to deduct from the Contract Price or consideration, the full amount of such commission, percentage, brokerage or contingent fee.

**7.8.3 Licensing and Permits:** The CONTRACTOR warrants that it shall have, prior to commencement of work under this Contract and at all times during said work, all required licenses and permits whether federal, state, County or City.

**7.8.4 Public Entity Crime Statement:** The CONTRACTOR warrants that it has not been placed on the convicted vendor list following a conviction for public entity crime, as specified in Section 00456, of the Instructions to Bidders.

**ARTICLE 8 – CONTRACT DOCUMENTS.**

**8.1** The Contract Documents listed below, which are listed in their order of precedence for the purpose of resolving conflicts, errors and discrepancies, by this reference shall become a part of the Contract as though physically attached as a part thereof:

**8.1.1** Change Orders.

**8.1.2** Field Orders.

**8.1.3** Contract for Construction.

**8.1.4** Exhibits to this Contract.

**8.1.5** Supplementary Conditions.

**8.1.6** General Conditions.

**8.1.7** Any federal, state, county or city permits for the Project

**8.1.8** Specifications bearing the title: (N/A)

**8.1.9** Drawings consisting of a cover sheet and inclusive of all sheets bearing the following general titles: **“Canal Bank Stabilization Program: Year 5A Phase II, ITB No. 2020-23”**

- 8.1.10** Bid Documents, including but not limited to: Addendum, Invitation to Bid, Instructions to Bidders, Bid Form provided by CONTRACTOR, Notice of Award and Notice to Proceed.
- 8.1.11** Addenda subject matter takes the same precedence of the respective subject matter that it is modifying. Furthermore, each subsequent addendum takes precedence over previous addenda.
- 8.1.12** The documents listed above shall be incorporated into this Contract (except as expressly noted otherwise above).
- 8.1.13** There are no Contract Documents other than those listed above in this Article. The Contract Documents may only be amended, modified or supplemented as provided in the General Conditions.
- 8.1.14** The Contract Documents shall remain the property of the CITY. The CONTRACTOR shall have the right to keep one record set of the Contract Documents upon completion of the Project; provided; however, that in no event shall the CONTRACTOR use, or permit to be used, any or all of such Contract Documents on other projects without the City's prior written authorization.
- 8.1.15** The General Conditions discuss the bond and surety requirements of the CITY. This Contract does [x], does not [ ] require bonds. If the Contract does not require bonds, the references to bonds in the General Conditions do not apply to this Contract.

**ARTICLE 9 – MISCELLANEOUS.**

**9.1** Terms used in this Contract which are defined in Article 1 of the General Conditions will have the meanings indicated in the General Conditions. Terms used in Article 1 of the Instructions to Bidders also apply to this Contract.

**9.2** Except as otherwise provided in the Contract Documents with respect to subcontractors, no assignment by a party hereto of any rights under or interests in the Contract Documents will be binding on another party thereto without the written consent of the party sought to be bound; and, specifically but without limitation, moneys that may become due and moneys that are due may not be assigned without such consent (except to the extent that the effect of this restriction may be limited by law), and unless specifically stated to the contrary in any written consent to an assignment no assignment will release or discharge the assignor from any duty or responsibility under the Contract Documents.

**9.3** CITY and CONTRACTOR each binds itself, its partners, successors, assigns and legal representatives to the other party hereto, its partners, successors, assigns and legal representatives in respect to all covenants, agreements and obligations contained in the Contract Documents.

**9.4** Severability. Should any provision, paragraph, sentence, word, or phrase contained in this Contract be determined by a court of competent jurisdiction to be invalid, illegal, or otherwise unenforceable under the laws of the State of Florida, such provision, paragraph, sentence, word, or

phrase shall be deemed modified to the extent necessary in order to conform with such laws, then shall be deemed severable, and in this Contract, shall remain unmodified and in full force and effect.

**9.5 Remedies.** If and when any default of this Contract occurs, the CITY may avail itself of any legal or equitable remedies that may apply, including, but not limited to, actual damages and specific performance. Such remedies may be exercised in the sole discretion of the CITY. Nothing contained in this Contract shall limit the CITY from pursuing any legal or equitable remedies that may apply.

**9.6 Access to Public Records.** The CONTRACTOR shall comply with the applicable provisions of Chapter 119, Florida Statutes. The CITY shall have the right to immediately terminate this contract for the refusal by the Contractor to comply with Chapter 119, Florida Statutes. The Contractor shall retain all records associated with this Contract for a period of five (5) years from the date of Final Payment or Termination of this Contract.

**9.7 Inspection and Audit.** During the term of this Contract and for five (5) years from the date of Termination, the CONTRACTOR shall allow CITY representatives access during reasonable business hours to CONTRACTOR’S records related to this Contract for the purposes of inspection or audit of such records. If upon an audit of such records, the CITY determines the CONTRACTOR was paid for services not performed, upon receipt of written demand by the CITY, the CONTRACTOR shall remit such payments to the CITY.

**9.8 Counterparts.** This contract may be signed in one or more counterparts, each of which when executed shall be deemed an original and together shall constitute one and the same instrument.

**9.9 Notices.** Whenever any party is required to give or deliver any notice to any other party, or desires to do so, such notices shall be sent via certified mail or hand delivery to:

FOR CITY:

Albert P. Childress, City Manager  
City of Doral  
8401 NW 53<sup>rd</sup> Terrace  
Doral, Florida 33166

WITH COPY TO:

Luis Figueredo, Esq.  
City Attorney  
City of Doral  
8401 NW 53<sup>rd</sup> Terrace  
Doral, Florida 33166

FOR CONTRACTOR:

\_\_\_\_\_  
\_\_\_\_\_  
\_\_\_\_\_  
\_\_\_\_\_



**9.10 WAIVER OF JURY TRIAL AND VENUE.** The CITY and CONTRACTOR knowingly, irrevocably, voluntarily and intentionally waive any right either may have to a trial by jury in State and or Federal court proceedings in respect to any action, proceeding, lawsuit or counterclaim based upon the Contract, arising out of, under, or in connection with the Work, or any course of conduct, course of dealing, statements or actions or inactions of any party. The venue for any lawsuit arising out of this Contract shall be in Miami-Dade County, Florida.

**9.11 Attorneys' Fees.** If either the CITY or CONTRACTOR is required to enforce the terms of the Contract by court proceedings or otherwise, whether or not formal legal action is required, the prevailing party shall be entitled to recover from the other party all such costs and expenses, including, but not limited to, court costs, and reasonable attorneys' fees at the trial and appellate level.

**9.12 Amendments.** This Contract may only be amended by the prior written approval of the parties or by execution of a Change Order in the form attached hereto as Exhibit "B".

IN WITNESS WHEREOF, the parties hereto have made and executed this Contract on the respective dates under each signature: THE CITY OF DORAL, FLORIDA, signing by and through its City Manager, authorized to execute same by Council action on the \_\_\_\_\_ day of \_\_\_\_\_, 20\_\_\_\_, and by \_\_\_\_\_(Contractor), signing by and through its \_\_\_\_\_, duly authorized to execute same.

WITNESS

CONTRACTOR

By: \_\_\_\_\_  
(Signature and Corporate Seal)

\_\_\_\_\_  
(Contractor)

\_\_\_\_\_  
(Print Name and Title)

\_\_\_\_\_  
(Signature)

\_\_\_\_\_  
(Print Name and Title)

\_\_\_\_\_ day of \_\_\_\_\_, 20\_\_\_\_\_.

ATTEST

CITY OF DORAL

\_\_\_\_\_  
Connie Diaz, City Clerk

\_\_\_\_\_  
Albert P. Childress, City Manager

APPROVED AS TO FORM AND LEGALITY FOR THE USE  
AND BENEFIT OF THE CITY OF DORAL ONLY:

\_\_\_\_\_  
Luis Figueredo, Esq., City Attorney

*(\*) In the event that the Contractor is a corporation, there shall be attached to each counterpart a certified copy of a resolution of the board of the corporation, authorizing the officer who signs the contract to do so in its behalf.*



Mr. Wilson Sanchez is a professional engineer registered in the State of Florida and a Certified General Contractor with many years of experience in civil engineering, construction, project management, and quality control. He currently serves as Managing Member and is responsible for overseeing projects, acquiring permits, and ensuring timely delivery and well-executed projects to our clients.

## EDUCATION & PROFESSIONAL REGISTRATION

---

### New Jersey Institute of Technology — Newark, NJ

- Bachelor of Science in Civil Engineering, 1993

## PROFESSIONAL REGISTRATIONS & AFFILIATIONS

---

- P.E. Florida License No.53209
- Certified General Contractor CGC060832
- Construction Training Qualification Program  
- Asphalt Technician 1 & 2 | QA/QC Manager
- Engineering Contractors Association (ECA)
- American Society of Civil Engineers (ASCE)

## RELEVANT EXPERIENCE

---

### Avondale Stormwater Improvements | Pompano Beach, FL

The Avondale Stormwater Improvements projects consists of installation of 1 new pump station, 61 drainage structures, 6767LF of RCP, and landscaping throughout. Mr. Sanchez was the Project Manager, working closely with the City and EOR to resolve conflicts with existing utilities, maintaining proper MOT for pedestrian and traffic, and maintaining project on schedule/budget.

### Park Improvements and Construction Term Contract | Broward County, FL

Term contract to provide general construction services to parks in Broward County, such as:

- *Hillsboro Pineland Natural Area Trail | Coconut Creek, FL*  
The project includes the design, permitting, and construction of a sidewalk, boardwalk, and outlook.
- *CB Smith Playground | Pembroke Pines, FL*  
Design/build project for construction of new playground, shade structure, and adjacent sidewalk.
- *Snake Warrior Vegetation Removal | Miramar, FL*  
Coordinate exotic vegetation removal.
- *Shooster Preserve Boardwalk | Margate, FL*  
Construction of boardwalk, gazebo, concrete path, and parking in an environmentally sensitive area.
- *Everglades Holiday Park – Fire Well | Fort Lauderdale, FL*  
The project includes construction of fire well and corresponding access road.

### SW 36<sup>th</sup> Avenue Sidewalk Project | Pompano Beach, FL

Located in Pompano Beach, FL this project consists of the construction of 3200 LF of sidewalk, curb & gutter, guardrail, striping and pavement markings, flashing beacons for designated pedestrian crossings, and channel improvements. Channel improvements include the installation of a new 60" dia. reinforced concrete pipe, as well as a new 10' retaining wall requiring sheet piling and continuous dewatering operations during construction. Mr. Sanchez was the Project Manager, and responsible for coordinating all work activities with the City, as well as close monitoring of budget and time.

### Progresso Neighborhood Improvements Project | Ft. Lauderdale, FL

This project consists of approximately 3 miles of new sidewalk, ADA accessible ramps, sodded swales, improved drainage systems, landscaping, and 159 solar-powered pedestrian lighting. It is helping to fulfill the community wide vision of "strengthening connectivity and creating safe, accessible, and pedestrian-friendly neighborhoods." As the Project Manager, Mr. Sanchez was responsible for all RFI resolution, attending project meetings, maintaining project on schedule/budget, and preparation of pay applications.

### **Margate and Coral Springs Bus Shelters: Design-Build | Margate, FL and Coral Springs, FL**

Eight bus shelters were built along Sample Road to encourage use of the Broward County Transit System by providing a safer, comfortable, and convenient alternative. Mr. Sanchez served as the Engineer of Record and Project Manager, designing 8 bus shelters with swale areas, foundations, and sidewalks.

### **Walkway & Bikeway System Phase III | Tamarac, FL**

This project consists of approximately 6 miles of bikeway and 1.2 miles of sidewalk created to enhance multi-modal transportation, wellness, and recreational opportunities throughout the City. It also includes new fire hydrants, drainage, and swale areas throughout. Mr. Sanchez was the Project Manager responsible for overseeing construction activities and ensuring project was finished on time and budget.

### **Rolling Oaks Park Pedestrian Trail | Miami Gardens, FL**

This 3000LF pedestrian trail winds Rolling Oaks Park providing a safe and alternate form of travel for the City's residents, as well as features new benches, LED lighting, and outdoor fitness stations. Mr. Sanchez served as the QA/QC Manager and oversaw all paving activities. He was also in charge of acquiring all necessary building, electrical, drainage, and traffic permits.

### **Broward Boulevard Park & Ride Surrounding Roadways | Ft. Lauderdale, FL**

This project's main goal was to facilitate access into and out of the park & ride. As such, turn lanes were added on the surrounding roadways, access roads were widened and re-paved, and a new bus bay was constructed. In addition, the project included a new lighting system, perimeter fencing, sidewalks, and drainage system. Mr. Sanchez was the Project Manager and responsible for overseeing all construction activities, as well as coordinating with the various sub-contractors.

### **North Perry Airport Park and Ride: Design-Build | Pembroke Pines, FL**

The park and ride facility located at the North Perry airport provides 175 parking spaces that allow residents in the vicinity to utilize Broward County Transit System. The new location has new drainage and lighting systems, landscaping, and perimeter fencing. Mr. Sanchez was the Project Manager and responsible for working closely with the Engineer of Record during the design-phase, as his experience and in construction was key in helping complete the project on a tight budget.

### **First City Hall Park Phase 1 | Lauderhill, FL**

This project includes the construction of a new park complete with drainage, water main, gazebos, water fountains, art components, lighting system, playground and corresponding shade structure, landscaping, and parking area. Mr. Sanchez was the Field Superintendent and coordinated daily construction activities.

### **Helene Klein Pineland Preserve | Pompano Beach, FL**

This project consisted of the construction of a new park throughout an environmentally sensitive area including 2500LF of colored concrete sidewalk, 550LF of recycled plastic boardwalk, gazebos, information kiosks, picnic tables, and benches. Mr. Sanchez was the Project Manager in charge of completing the project on time/budget, preparing pay applications, procuring materials to site, and acquiring permits.

## **EXPERIENCE PRIOR TO ENCO, LLC**

### **Keith & Associates, Inc | Engineering Director**

Managed the Civil Engineering department consisting of 13 employees including engineers, inspectors, and construction technicians. Oversaw the planning, design, permitting, and construction administration phases of public and private projects. Responsible for preparation of proposals, budgeting, and invoicing.

- **Hillsboro Boulevard (SR 810) Improvements, Deerfield Beach, FL**

Reconstruction and beautification improvement project of approximately 1.5 miles of roadway including drainage improvements, culvert/bridge restoration, landscape, irrigation, hardscape features, bike lanes, burial of FPL overhead lines, lighting, and mast arms at three intersections with a construction cost of ~\$7.5 million. Facilitated negotiations between City, FDOT and FPL.

- **Atlantic Boulevard Safety Improvement Project, Pompano Beach, FL**

Managed the consultant performing the design and permitting of the Atlantic Boulevard Safety Improvement Project under a FDOT LAP agreement, and on behalf of the City of Pompano beach.

- **State Road A1A (“S” Curve)**, Deerfield Beach, FL  
Involved in the conceptual design and estimating of the realignment of a portion of State Road A1A, known as the “S” curve. Involved in assisting the City of Deerfield Beach work with Broward County MPO to add this project to the unfounded list.
- **Broward County Intersection Improvements**, Broward County, FL  
Part of a consulting team providing design and permitting services associated with safety improvements for various intersections throughout Broward County
- **Harbor Drive Area Improvements**, Pompano Beach, FL  
Project manager in charge of design, permitting and construction administration of a beautification and improvement project including full reconstruction of ~1.5 miles of roadway, drainage, water, sanitary sewer, force main, two 2 lift stations, reclaimed water main, new landscape medians, irrigation, hardscape features and traffic circles. Total construction cost is \$6.5 million.



Mr. Lucio Micolta is a civil engineer with many years of experience in the construction industry having managed a myriad of projects in South America and the United States. He has extensive knowledge in effective construction practices and project management, and currently serves as Construction Manager. His responsibilities include project selection, cost estimation as well as ensuring safe and effective methods of construction for all projects.

## EDUCATION

---

**Saint Thomas Aquinas University** — Bogotá, Colombia

- Bachelor of Science in Civil Engineering, 1980

## PROFESSIONAL REGISTRATIONS & AFFILIATIONS

---

- MOT Intermediate #15717
- Engineering Contractors Association (ECA)

## RELEVANT EXPERIENCE

---

**North Perry Airport Park and Ride: Design-Build** | *Pembroke Pines, FL*

The park and ride facility located at the North Perry airport provides 175 parking spaces that allow residents in the vicinity to utilize Broward County Transit System. The new location has new drainage and lighting systems, landscaping, and perimeter fencing. Mr. Micolta was the Construction in charge of maintaining working relationship with inspectors and ensuring accurate construction of project.

**Rolling Oaks Park Pedestrian Trail** | *Miami Gardens, FL*

This 3000LF pedestrian trail winds Rolling Oaks Park providing a safe and alternate form of travel for the City's residents, as well as features new benches, LED lighting, and outdoor fitness stations. Mr. Micolta was the Project Manager and responsible for overseeing all construction activities, tabulating quantities for pay applications, attending weekly project meetings, and ensuring project completion on time and budget.

**Canal Bank Stabilization, Year 5a** | *Doral, FL*

The City of Doral Canal Bank Stabilization project uses geoweb panels to stabilize about 8500 LF of bank along the Dressel's Dairy Canal that have severely eroded. It also includes a 2600' long and 10' wide asphalt path adjacent to the canal. Mr. Micolta was the Construction Manager.

**Canal Bank Stabilization, Year 5b** | *Doral, FL*

The City of Doral Canal Bank Stabilization project stabilizes 8650LF of bank using geoweb panels and 2100LF using a rip rap system along the Dressel's Dairy Canal that have severely eroded. It also includes a 5400' long and 10' wide asphalt path adjacent to the canal. Mr. Micolta was the Construction Manager.

**C-4 Canal Bank Improvements, Palmetto Phase 2 Flood Protection Berm** | *Miami, FL*

The Palmetto Phase Berm project is a continuation of the greater scale C-4 Canal Flood Protection Project that was created as a response to flooding resulting from Hurricane Irene in 1999 and another no name storm in 2000. It involves raising 2,500LF of canal bank to elevation 8.3ft NGVD29. Similar to the other phases, it also includes an integrated storm-water drainage collection and disposal system, and high-performance turf reinforcement mat to prevent further canal bank erosion. Mr. Micolta was the Construction Manager, ensuring project would be completed on time and on budget.

**Canal Bank Stabilization, Year 7** | *Doral, FL (In progress)*

The City of Doral Canal Bank Stabilization project uses geoweb panels to stabilize about 4400 LF of bank along the Northline Canal and 1700 LF of bank along the Residential Canal that have severely eroded. Due to limited space available on the canal bank, the entire Residential Canal must be done from the water. Mr. Micolta was the Construction Manager, ensuring project would be completed on time and on budget.

### **EWP Canals 20 & 30 Bank Stabilization | *Lauderhill, FL***

This project stabilizes 2400LF of canal bank in residential areas using 26' to 35' long sheet piles. As the canal had limited ROW, most of the work was completed from the water using barges. Mr. Micolta was the Construction Manager/Project Superintendent, managing a 10 person field crew and working closely with the EOR and City to ensure project would be completed on time and budget.

### **Canal Bank Stabilization, Phase 1 | *Miami Lakes, FL***

The Miami Lakes Canal Bank Stabilization project uses geoweb panels to stabilize about 3000 LF of bank along the Golden Glades and Peter's Pike Canal that have severely eroded. Due to limited ROW space, all for this project was done from the water side. Mr. Micolta was the Construction Manager, ensuring project would be completed on time and on budget.

### **C-4 Canal Bank Improvements, Palmetto Phase 1 Flood Protection Berm | *Miami, FL***

The Palmetto Phase Berm project is a continuation of the greater scale C-4 Canal Flood Protection Project that was created as a response to flooding resulting from a hurricane Irene in 1999 and another no name storm in 2000. It involves raising 6,000LF of canal bank to elevation 8ft NGVD29. Like the Sweetwater phase completed, it also includes an integrated storm-water drainage collection and disposal system, and high-performance turf reinforcement mat to prevent further canal bank erosion. Mr. Micolta was the Construction Manager, supervising all field activities and corresponding with sub-contractors.

### **C-4 Canal Bank Improvements, Sweetwater Flood Protection Berm | *Miami, FL***

This project incorporates raising 5,000LF of canal bank to elevation 8 ft. NGVD29, an integrated storm-water drainage collection and disposal system, and high-performance turf reinforcement mat to prevent further canal bank erosion when water level rise. It is part of the larger scale C-4 Canal Flood Protection Project that was created as a response to the flooding resulting from a hurricane in 1999 and another no name storm in 2000. Mr. Micolta was the Construction Manager, supervising all field activities.

### **Red Reef Park Boardwalk & Pavilion | *Boca Raton, FL***

The City of Boca Raton Red Reef Park project consists of construction 2500LF of recycled plastic coastal dune boardwalk decking, 4 dune crossovers, 5 pavilions, a turtle-safe lighting system, and upgrades to the existing water system throughout an environmentally sensitive area near the Coastal Construction Control Line. Mr. Micolta was the Construction Manager supervising field crew and ensuring boardwalk, deck, and gazebos were according to drawings and specifications.

### **Margate and Coral Springs Bus Shelters: Design-Build | *Margate, FL and Coral Springs, FL***

Eight bus shelters were built along Sample Road to encourage use of the Broward County Transit System by providing a safer, comfortable, and convenient alternative. Mr. Micolta was the Construction Manager, participating actively during design/construction phases. He provided design ideas that minimized duration resulting in reduced construction costs, and supervised the field crew on daily basis ensuring quality work.

### **Renovations and Modifications of Buildings 4181 & 4183 | *West Palm Beach, FL***

The Florida's Turnpike Maintenance Compound Renovations project includes both interior and exterior renovations of buildings #4181 and #4183. Interior renovations consisted of new ADA compliant restrooms, sanitary lines, HVAC & electrical systems, and lighting. Outside renovations include removal of existing doors and windows and infill with CMU stucco, replacement of roof, and new 5.5' x 13.5' x 2.5' pile cap footings. Mr. Micolta was the Field Superintendent overseeing all field activities, maintaining accurate quantities for pay applications, and keeping project on schedule.

### **Fern Forest Nature Center | *Coconut Creek, FL***

The Fern Forest Nature Center project included the renovations of existing bathrooms, dressing rooms, and kitchen through structural, plumbing, and electrical upgrades. There was also the construction of 430LF of recycled plastic boardwalk and one gazebo. Mr. Micolta was the Field Superintendent and Construction Manager in charge of supervising field crew, procurement, and minimizing impact of construction activities on environmentally sensitive areas.



Ms. Isabella Micolta is a civil engineer. She came to **ENCO, LLC** after working in the nuclear energy sector as a Design Engineer and currently serves as Project Engineer. Her responsibilities include project support during bidding and construction, such as preparing proposals and Statements of Qualifications (SOQs), developing and enforcing project specific Safety Plans & Stormwater Pollution Prevention Plans (SWPPP), preparing shopdrawings and pay applications, as well as procuring materials for job sites and helping the project be completed on time and budget.

## **EDUCATION**

---

### **Georgia Institute of Technology — Atlanta, GA**

- Bachelor of Science in Civil Engineering, 2012 (Magna Cum Laude)
- Master of Science in Civil Engineering, 2013

## **PROFESSIONAL REGISTRATIONS & AFFILIATIONS**

---

- P.E. Florida License No.84359
- 30 hour OSHA Certification
- FDEP Inspector, 32643
- MOT Advanced Certification, 8016
- American Society of Civil Engineers (ASCE)
- Engineering Contractors Association (ECA)

## **RELEVANT EXPERIENCE**

---

### **Broward Boulevard Park & Ride Surrounding Roadways | Ft. Lauderdale, FL**

This project's main goal was to facilitate access into and out of the park & ride. As such, turn lanes were added on the surrounding roadways, access roads were widened and re-paved, and a new bus bay was constructed. In addition, the project included a new lighting system, perimeter fencing, sidewalks, and drainage system. Ms. Micolta oversaw paving activities, monitored that appropriate tonnage was used per square yard to meet specified spread rate, and helped prepare FDOT Daily Asphalt Reports.

### **Canal Bank Stabilization, Year 5a | Doral, FL**

The City of Doral Canal Bank Stabilization project uses geoweb panels to stabilize 8500LF of bank along the Dressel's Dairy Canal that have severely eroded. It also includes a 2600' long and 10' wide asphalt path adjacent to the canal. Ms. Micolta served as the Project Engineer, in charge of procuring materials as needed, supervising field crew, and preparing pay applications.

### **Canal Bank Stabilization, Year 5b | Doral, FL**

The City of Doral Canal Bank Stabilization project stabilizes 8650LF of bank using geoweb panels and 2100LF using a rip rap system along the Dressel's Dairy Canal that have severely eroded. It also includes a 5400' long and 10' wide asphalt path adjacent to the canal. Ms. Micolta served as the Project Engineer, in charge of procuring materials as needed, supervising field crew, and preparing pay applications.

### **Canal Bank Stabilization, Year 7 | Doral, FL (*In progress*)**

The City of Doral Canal Bank Stabilization project uses geoweb panels to stabilize about 4400 LF of bank along the Northline Canal and 1700 LF of bank along the Residential Canal that have severely eroded. Due to limited space available on the canal bank, the entire Residential Canal must be done from the water. Ms. Micolta served as the Project Engineer, in charge of procuring materials as needed, supervising field crew, and preparing pay applications.

### **EWP Canals 20 & 30 Bank Stabilization | Lauderhill, FL**

This project stabilizes 2400LF of canal bank in residential areas using 26' to 35' long sheet piles. As the canal had limited ROW, most of the work was completed from the water using barges. Ms. Micolta served as the Project Engineer, coordinating fabrication & delivery of sheet piles to ensure a tight project schedule was maintained, worked closely with the EOR to resolve any RFIs, and prepared pay applications.



#### **Canal Bank Stabilization, Phase 1 | Miami Lakes, FL**

The Miami Lakes Canal Bank Stabilization project uses geoweb panels to stabilize about 3000 LF of bank along the Golden Glades and Peter's Pike Canal that have severely eroded. Due to limited ROW space, all for this project was done from the water side. Ms. Micolta served as the Project Engineer, in charge of procuring materials as needed, supervising field crew, and preparing pay applications.

#### **C-4 Canal Bank Improvements, Palmetto Phase 2 Flood Protection Berm | Miami, FL**

The Palmetto Phase Berm project is a continuation of the greater scale C-4 Canal Flood Protection Project that was created as a response to flooding resulting from Hurricane Irene in 1999 and another no name storm in 2000. It involves raising 2,500LF of canal bank to elevation 8.3ft NGVD29. Similar to the other phases, it also includes an integrated storm-water drainage collection and disposal system, and high-performance turf reinforcement mat to prevent further canal bank erosion. Ms. Micolta serves as the Project Engineer and is in charge of procurement of materials needed, coordinating with sub-contractor, preparing pay application, and supervising field crew activities.

#### **C-4 Canal Bank Improvements, Palmetto Phase 1 Flood Protection Berm | Miami, FL**

The Palmetto Phase Berm project is a continuation of the greater scale C-4 Canal Flood Protection Project that was created as a response to flooding resulting from Hurricane Irene in 1999 and another no name storm in 2000. It involves raising 6,000LF of canal bank to elevation 8.3ft NGVD29. Like the Sweetwater phase completed, it also includes an integrated storm-water drainage collection and disposal system, and high-performance turf reinforcement mat to prevent further canal bank erosion. Ms. Micolta serves as the Project Engineer and is in charge of procurement of materials needed, coordinating with sub-contractor, preparing pay application, and supervising field crew activities.

#### **C-4 Canal Bank Improvements, Sweetwater Flood Protection Berm | Miami, FL**

This project incorporates raising 5,000LF of canal bank to elevation 8.3ft. NGVD29, an integrated storm-water drainage collection and disposal system, and high-performance turf reinforcement mat to prevent further canal bank erosion when water level rise. It is part of the larger scale C-4 Canal Flood Protection Project that was created as a response to flooding resulting from Hurricane in 1999 and another no name storm in 2000. Ms. Micolta was the Project Engineer in charge of maintaining working relationships with over 75 residents to facilitate project completion, recording daily field reports, helping with successful RFI resolution and necessary change orders, preparing pay applications, as well as developing and enforcing the project specific SWPPP (Storm Water Pollution Protection Plan).

### **EXPERIENCE PRIOR TO ENCO, LLC**

#### **Enercon Services, Inc. | Civil/Structural Engineer**

- **Edwin I. Hatch Nuclear Plant FLEX Project | Atlanta, GA**  
FLEX is a strategy developed to address Fukushima task force recommendations in all nuclear plants across the United States. The main issue identified is the plant losing cooling capabilities as a result of power outage. Ms. Micolta was the Responsible Engineer in charge of designing new conduit runs in Switchgear Rooms 2E and 2F, as well as participating in walk-throughs to assess constructability of the proposed design.
- **Joseph M. Farley Nuclear Plant FLEX Project | Atlanta, GA**  
FLEX is a strategy developed to address Fukushima task force recommendations in all nuclear plants across the United States. The main issue identified is the plant losing cooling capabilities as a result of power outage. Ms. Micolta was tasked with researching plant drawings in database to help team effectively design conduit runs by avoiding coring walls containing wires that could result in plant shutdown. She also designed conduit runs and performed calculations dictating whether or not certain walls could be cored.



Mr. Andion is a Civil Engineer in charge of overseeing every stage of the project, he provides support in the construction management, permitting and design. Among the duties and responsibilities in ENCO, LLC include estimating, bidding, shop drawing review, contract review and inspections.

## **EDUCATION**

---

**Florida International University**– Miami, Florida

- Bachelor of Science in Civil Engineering, 2017

## **PROFESSIONAL REGISTRATIONS & AFFILIATIONS**

---

- MOT Advanced Certification
- American Society of Civil Engineers (ASCE)

## **RELEVANT EXPERIENCE**

---

**Avondale Stormwater Improvements** | *Pompano Beach, FL*

This project consists of installation of 1 new pump station, 61 drainage structures, 6800 LF of RCP, and landscaping throughout. Mr. Andion is the project engineer, responsible for procuring materials as needed.

**Park Improvements and Construction Term Contract** | *Broward County, FL*

Term contract to provide general construction services to parks in Broward County, such as:

- *Hillsboro Pineland Natural Area Trail* | *Coconut Creek, FL*  
The project includes the design, permitting, and construction of a sidewalk, boardwalk, and outlook at Hillsboro Pineland Natural Area. Mr. Andion was the Project Engineer facilitating all required permitting and design coordination.
- *Willow Pond Natural Area- Maintenance Entrance Driveway* | *Fort Lauderdale, FL*  
The project includes construction of a concrete driveway and removal of a existing sidewalk. Mr. Andion was the Project Engineer in charge of the execution of the project according to County specifications.
- *C.B Smith Park – New Playground Area* | *Pembroke Pines, FL*  
The project consisted in the drainage and groundwork for children playground to be installed as well as the construction of access sidewalk. Mr. Andion was the Project Engineer responsible for coordinating project sequence

## **EXPERIENCE PRIOR TO ENCO, LLC**

**Building Drops (Dania Beach, FL)** | *Structural Designer & Drafter*

- Perform structural analysis calculations for fenestration projects that were to be part of structural composition of residential construction.
- Produce & review shop drawings to be in accordance with the Florida Building Code for product approvals.

**Americaribe/Bouygues Batiment (Miami, FL)** | *Punchlist Inspector*

- While still a student, Mr. Andion had the opportunity to work at the late stages of the multibillion dollar project of Brickell City Centre which consisted of a shopping mall, two residential towers and a hotel.



Mr. Sandy Sepulveda is a civil engineer with years of experience in the construction industry, both in the Dominican Republic and United States. He has experience in commercial and residential construction, earthwork, and construction management. He currently serves as Field Superintendent and is responsible for running daily operations in the field and enforcing safety standards.

## **EDUCATION**

---

**Eastern Central University** — San Pedro de Macoris, Dominican Republic

- Bachelor of Science in Civil Engineering, 2006

## **PROFESSIONAL REGISTRATIONS & AFFILIATIONS**

---

- Engineering Contractors Association (ECA)

## **RELEVANT EXPERIENCE**

---

### **Broward Boulevard Park & Ride Surrounding Roadways | Ft. Lauderdale, FL**

This project's main goal was to facilitate access into and out of the park & ride. As such, turn lanes were added on the surrounding roadways, access roads were widened and re-paved, and a new bus bay was constructed. In addition, the project included a new lighting system, perimeter fencing, sidewalks, and drainage system. As the Field Superintendent, Mr. Sepulveda supervised daily construction activities and coordinated with electrical and paving sub-contractors.

### **North Perry Airport Park and Ride: Design-Build | Pembroke Pines, FL**

The park and ride facility located at the North Perry airport provides 175 parking spaces that allow residents in the vicinity to utilize Broward County Transit System. The new location has new drainage and lighting systems, landscaping, and perimeter fencing. Mr. Sepulveda was the Field Superintendent in charge of overseeing daily construction activities, setting up and removing MOT (Maintenance of Traffic) daily, and maintaining working relationship with inspectors.

### **Rolling Oaks Park Pedestrian Trail | Miami Gardens, FL**

This 3000LF pedestrian trail winds Rolling Oaks Park providing a safe and alternate form of travel for the City's residents, as well as features new benches, LED lighting, and outdoor fitness stations. Mr. Sepulveda was the Field Superintendent overseeing a 4 person field crew during all construction tasks. He closely monitored paving activities ensuring daily spread rates were met.

### **Canal Bank Stabilization, Year 5a | Doral, FL**

The City of Doral Canal Bank Stabilization project uses geoweb panels to stabilize about 8500 LF of bank along the Dressel's Dairy Canal that have severely eroded. It also includes a 2600' long and 10' wide asphalt path adjacent to the canal. Mr. Sepulveda was the Field Superintendent, supervising all field activities and corresponding with sub-contractors.

### **Canal Bank Stabilization, Year 5b | Doral, FL**

The City of Doral Canal Bank Stabilization project stabilizes 8650LF of bank using geoweb panels and 2100LF using a rip rap system along the Dressel's Dairy Canal that have severely eroded. It also includes a 5400' long and 10' wide asphalt path adjacent to the canal. Mr. Sepulveda was the Field Superintendent, supervising all field activities and corresponding with sub-contractors.

### **Canal Bank Stabilization, Year 7 | Doral, FL (*In progress*)**

The City of Doral Canal Bank Stabilization project uses geoweb panels to stabilize about 4400 LF of bank along the Northline Canal and 1700 LF of bank along the Residential Canal that have severely eroded. Due to limited space available on the canal bank, the entire Residential Canal must be done from the water. Mr. Sepulveda was the Field Superintendent, supervising all field activities and corresponding with subs

### **Progreso Neighborhood Improvements Project | Ft. Lauderdale, FL**

This project consists of approximately 3 miles of new sidewalk, ADA accessible ramps, sodded swales, improved drainage systems, landscaping, and 159 beautiful solar-powered pedestrian lighting. It is helping to fulfill the community wide vision of “strengthening connectivity and creating safe, accessible, and pedestrian-friendly neighborhoods.” Mr. Sepulveda was the Field Superintendent in charge of supervising field crew, managing daily construction activities, and maintaining daily MOT (Maintenance of Traffic).

### **C-4 Canal Bank Improvements, Palmetto Phase 2 Flood Protection Berm | Miami, FL**

The Palmetto Phase Berm project is a continuation of the greater scale C-4 Canal Flood Protection Project that was created as a response to flooding resulting from Hurricane Irene in 1999 and another no name storm in 2000. It involves raising 2,500LF of canal bank to elevation 8.3ft NGVD29. Similar to the other phases, it also includes an integrated storm-water drainage collection and disposal system, and high-performance turf reinforcement mat to prevent further canal bank erosion. Mr. Sepulveda was the Field Superintendent, supervising all field activities and corresponding with sub-contractors.

### **C-4 Canal Bank Improvements, Palmetto Phase 1 Flood Protection Berm | Miami, FL**

The Palmetto Phase Berm project is a continuation of the greater scale C-4 Canal Flood Protection Project that was created as a response to flooding resulting from Hurricane Irene in 1999 and another no name storm in 2000. It involves raising 6,000LF of canal bank to elevation 8ft NGVD29. Like the Sweetwater phase completed, it also includes an integrated storm-water drainage collection and disposal system, and high-performance turf reinforcement mat to prevent further canal bank erosion. Mr. Sepulveda was the Field Superintendent, supervising all field activities and corresponding with sub-contractors.

### **C-4 Canal Bank Improvements, Sweetwater Flood Protection Berm | Miami, FL**

This project incorporates raising 5,000LF of canal bank to elevation 8 ft. NGVD29, an integrated storm-water drainage collection and disposal system, and high-performance turf reinforcement mat to prevent further canal bank erosion when water level rise. It is part of the larger scale C-4 Canal Flood Protection Project that was created as a response to the flooding resulting from Hurricane in 1999 and another no name storm in 2000. Mr. Sepulveda was the Field Superintendent, supervising all field activities and corresponding with sub-contractors.

## **EXPERIENCE PRIOR TO ENCO, LLC**

### **City of Consuelo Town Hall (Dominican Republic) | Project Coordinator**

- Charged with inspecting project sites in order to monitor progress and adherence to specifications; as well as comply with safety protocols and state sanitation standards

### **Peluchs Company (Dominican Republic) | Project Supervisor**

- Tasked with estimating material costs and quantities needed for job, as well as determining adequate equipment and labor force to minimize project duration while staying under budget
- Performed project site visits during construction to monitor progress and consult with contractors and on-site engineers
- Review pre-set calculations and analytical data in order to maintain technical reports accurate and up-to-date.



With combined international experience among Cuba, Portugal and the U.S, Mr. Garcia plays an important leading role onsite. His vast knowledge of the construction ground is certainly an asset for all of the projects he is involved with. He is currently responsible for quality control, inspect, schedule and oversee the construction to run on the critical path and ensure timely completion.

## **EDUCATION**

---

### **Camaguey University — Camaguey, Cuba**

- ♦ Bachelor of Science in Civil Engineering, 2006

## **RELEVANT EXPERIENCE**

---

### **Avondale Stormwater Improvements | Pompano Beach, FL**

This project consists of installation of 1 new pump station, 61 drainage structures, 6800 LF of RCP, and landscaping throughout. Mr. Garcia is the onsite superintendent responsible for supervising crew activity.

### **Hillsboro Pineland Natural Area Addition | Coconut Creek, FL**

This project's main goal was to create a concrete trail and elevated walkway at the park for recreation and allowance of pedestrians in the area; Mr. Garcia managed the project in a manner to ensure the protection, restoration and preservation of the nature and habitat at the site.

### **Willow Pond Natural Area Maintenance Entrance Driveway | Coconut Creek, FL**

The project's scope of work included the removal of an existing sidewalk to be reconstructed and to create a driveway entrance for automobiles, Mr. Garcia was in charge of the construction to comply with the specification's requirements.

### **CB Smith Park New Playground Area | Pembroke Pines, FL**

This project consisted of the creation of a new playground structure as well as a sidewalk surrounding the area. Following protocols of safety of the public was key on Mr. Garcia part, as well as performing the work on time and within budget

## **EXPERIENCE PRIOR TO ENCO, LLC**

### **AG Contractors (Miami, FL) | Project Manager**

- ♦ Mr. Garcia was involved with construction of the Staybridge Suites Hotel.

### **Aziconstroi (Portugal) | Engineer Manager & Inspector**

- ♦ Among the projects Mr. Garcia participated in his nine years with the company were: the construction of Clinical Surgical Hospital, offices for the Ministry of Transport, warehouse complex in steel structure, Soap Factory, Ceramics Factory and offices for the Ministry of Justice, Construction of the sports complex of the Salesianos of Don Bosco & construction of the water treatment plant and water supply system were also part of his work.

### **Constructora Social de la Vivienda (Cuba) | Company Manager, Engineering Supervisor**

- ♦ In his hometown, he participated in the housing construction of multifamily buildings, construction of Bank (CADECA), the construction of Telecenter & Construction Specialties Polytecnic.

### **UNECA (Cuba) | Project Manager & Engineer Inspector**

- ♦ Mr. Garcia participated in the construction and installation of high buildings; construction of sulfuric acid base. Also was involved with the termination of the International Clinic tourist resort of Santa Lucia as well as railway constructions and construction of multifamily buildings in Camaguey City; As well as being Project manager in the construction of the 5 Stars Hotel Paradisus in the tourist resort of Varadero



# CERTIFICATE OF LIABILITY INSURANCE

DATE (MM/DD/YYYY)

07/17/2020

THIS CERTIFICATE IS ISSUED AS A MATTER OF INFORMATION ONLY AND CONFERS NO RIGHTS UPON THE CERTIFICATE HOLDER. THIS CERTIFICATE DOES NOT AFFIRMATIVELY OR NEGATIVELY AMEND, EXTEND OR ALTER THE COVERAGE AFFORDED BY THE POLICIES BELOW. THIS CERTIFICATE OF INSURANCE DOES NOT CONSTITUTE A CONTRACT BETWEEN THE ISSUING INSURER(S), AUTHORIZED REPRESENTATIVE OR PRODUCER, AND THE CERTIFICATE HOLDER.

**IMPORTANT:** If the certificate holder is an ADDITIONAL INSURED, the policy(ies) must have ADDITIONAL INSURED provisions or be endorsed. If SUBROGATION IS WAIVED, subject to the terms and conditions of the policy, certain policies may require an endorsement. A statement on this certificate does not confer rights to the certificate holder in lieu of such endorsement(s).

<b>PRODUCER</b> Insurance Consulting Group, LLC 1825 Main Street Suite 102 Weston FL 33326	<b>CONTACT NAME:</b> Diana Rodriguez <b>PHONE (A/C, No, Ext):</b> (305) 347-5651 <b>E-MAIL ADDRESS:</b> Dianar@insurancecgc.com	<b>FAX (A/C, No):</b> (844) 593-9453	
	<b>INSURER(S) AFFORDING COVERAGE</b>		<b>NAIC #</b>
<b>INSURED</b> Enco, LLC 5411 SW 25th Court Pembroke Park FL 33023	<b>INSURER A:</b> Tokio Marine Specialty		19046
	<b>INSURER B:</b> Travelers C&S of Illinois		
	<b>INSURER C:</b> AIG		
	<b>INSURER D:</b> Travelers property and casualty Company of America		
	<b>INSURER E:</b> StarNet Insurance Company		
<b>INSURER F:</b>			

**COVERAGES**

CERTIFICATE NUMBER: 2019

REVISION NUMBER:

THIS IS TO CERTIFY THAT THE POLICIES OF INSURANCE LISTED BELOW HAVE BEEN ISSUED TO THE INSURED NAMED ABOVE FOR THE POLICY PERIOD INDICATED. NOTWITHSTANDING ANY REQUIREMENT, TERM OR CONDITION OF ANY CONTRACT OR OTHER DOCUMENT WITH RESPECT TO WHICH THIS CERTIFICATE MAY BE ISSUED OR MAY PERTAIN, THE INSURANCE AFFORDED BY THE POLICIES DESCRIBED HEREIN IS SUBJECT TO ALL THE TERMS, EXCLUSIONS AND CONDITIONS OF SUCH POLICIES. LIMITS SHOWN MAY HAVE BEEN REDUCED BY PAID CLAIMS.

INSR LTR	TYPE OF INSURANCE	ADDL INSD	SUBR WVD	POLICY NUMBER	POLICY EFF (MM/DD/YYYY)	POLICY EXP (MM/DD/YYYY)	LIMITS	
A	<input checked="" type="checkbox"/> <b>COMMERCIAL GENERAL LIABILITY</b> <input type="checkbox"/> CLAIMS-MADE <input checked="" type="checkbox"/> OCCUR GEN'L AGGREGATE LIMIT APPLIES PER: <input checked="" type="checkbox"/> POLICY <input type="checkbox"/> PRO-JECT <input type="checkbox"/> LOC OTHER:	Y	Y	PPK2072264	12/10/2019	12/10/2020	EACH OCCURRENCE	\$ 1,000,000
	DAMAGE TO RENTED PREMISES (Ea occurrence)						\$ 100,000	
B	<input checked="" type="checkbox"/> ANY AUTO <input checked="" type="checkbox"/> OWNED AUTOS ONLY <input type="checkbox"/> HIRED AUTOS ONLY <input type="checkbox"/> SCHEDULED AUTOS <input type="checkbox"/> NON-OWNED AUTOS ONLY	Y		BA-8N546214-19-42-G	12/10/2019	12/10/2020	COMBINED SINGLE LIMIT (Ea accident)	\$ 1,000,000
	BODILY INJURY (Per person)						\$	
C	<input checked="" type="checkbox"/> <b>UMBRELLA LIAB</b> <input checked="" type="checkbox"/> <b>EXCESS LIAB</b> <input type="checkbox"/> OCCUR <input type="checkbox"/> CLAIMS-MADE DED RETENTION \$	Y		EBU 011054932	12/10/2019	12/10/2020	EACH OCCURRENCE	\$ 3,000,000
	AGGREGATE						\$ 3,000,000	
E	<b>WORKERS COMPENSATION AND EMPLOYERS' LIABILITY</b> ANY PROPRIETOR/PARTNER/EXECUTIVE OFFICER/MEMBER EXCLUDED? (Mandatory in NH) If yes, describe under DESCRIPTION OF OPERATIONS below	N/A	Y	KEY0139334	07/01/2020	07/01/2021	PER STATUTE	OTH-ER
	E.L. EACH ACCIDENT						\$ 1,000,000	
D	Contractors Equipment			QT-660-3H560612	03/21/2020	03/21/2021	Listed Items	809,368
							Leased or rented	50,000
							Basic Deductible	1,000

DESCRIPTION OF OPERATIONS / LOCATIONS / VEHICLES (ACORD 101, Additional Remarks Schedule, may be attached if more space is required)

Doral Canal Stabilization Year 5A-Phase II  
 City of Doral listed as an additional insured  
 Contingent & Contractual Liability  
 Premises and Operations Liability  
 Primary Insurance Clause Endorsement  
 Explosion, Collapse & Underground Hazard  
 Waiver of Subrogation in favor of City

**CERTIFICATE HOLDER****CANCELLATION**

City of Doral, Florida 8401 NW 53rd Terrace Doral FL 33166	SHOULD ANY OF THE ABOVE DESCRIBED POLICIES BE CANCELLED BEFORE THE EXPIRATION DATE THEREOF, NOTICE WILL BE DELIVERED IN ACCORDANCE WITH THE POLICY PROVISIONS.  AUTHORIZED REPRESENTATIVE 
--	--

© 1988-2015 ACORD CORPORATION. All rights reserved.



RICK SCOTT, GOVERNOR

JONATHAN ZACHEM, SECRETARY



**STATE OF FLORIDA**  
**DEPARTMENT OF BUSINESS AND PROFESSIONAL REGULATION**

**CONSTRUCTION INDUSTRY LICENSING BOARD**

THE GENERAL CONTRACTOR HEREIN IS CERTIFIED UNDER THE  
PROVISIONS OF CHAPTER 489, FLORIDA STATUTES

**SANCHEZ, WILSON**

ENCO LLC  
5411 SW 25TH COURT  
5411  
PEMBROKE PARK FL 33023

**LICENSE NUMBER: CGC060832**

**EXPIRATION DATE: AUGUST 31, 2020**

Always verify licenses online at [MyFloridaLicense.com](http://MyFloridaLicense.com)



Do not alter this document in any form.

This is your license. It is unlawful for anyone other than the licensee to use this document.

## EQUIPMENT RESOURCES

We take great pride in owning such a diverse fleet of equipment, and do everything in our power to ensure it is always in optimal condition. That way, our client can rest assured that their project will be completed in a timely & well-executed manner.



Dump Truck



Isuzu NPR



CAT 320 Excavator



CAT 416F Backhoe



Dump Truck



Isuzu NPR



CAT 320 Excavator



CAT 416D Backhoe



Dump Truck



CAT326 LR Excavator



Bobcat S650



Wacker Roller



Small Dump Truck



CAT D3G Dozer



Bobcat S650



Dynapac Roller



Water Truck



Champion Grader



CAT 930G Loader



24' Boat





**City of Doral**  
**Invitation to Bid**  
***Canal Bank Stabilization***  
***Program: Year 5A Phase II***

**ITB No. 2020-23**



## City of Doral

### Invitation to Bid

#### Canal Bank Stabilization Program: Year 5A Phase II

#### ITB No. 2020-23

NOTICE: Pursuant to the City of Doral Procurement Ordinance, sealed bids for consideration to provide the services detailed in the scope of services listed below, shall be received by Albert P. Childress, City Manager, City of Doral, 8401 NW 53<sup>rd</sup> Terrace Doral, Florida 33166 until **10:00 am on July 23<sup>rd</sup>, 2020**. Responses must be submitted electronically through DemandStar or Vendor Registry by the date and time stated above. Any proposals received after the due date and time specified, will not be considered. See attached instructions for further details on E-Bidding. Emailed or faxed submittals will not be accepted. Bids shall be clearly identified "**Canal Bank Stabilization Program: Year 5A Phase II, ITB No. 2020-23**".

**All bids shall be publicly opened and recorded on July 23<sup>rd</sup>, 2020 at 10:00 am.** Late submittals shall not be accepted or considered. **A mandatory pre-bid conference shall be held on July 7<sup>th</sup>, 2020 at 10:00 a.m. via Gotomeeting.**

The City of Doral reserves the right to accept any bid deemed to be in the best interest of the City or to waive any informality in any proposal. The City may reject any or all bids and re-advertise.

## **PROJECT OVERVIEW**

By way of this ITB, the City is soliciting bids from, and desires to retain the services of, a qualified State of Florida licensed Contractor or a Miami-Dade County Certified Engineering Contractor to restore and stabilize canal banks for various sections of the Dressels Canal within the City of Doral and 5 years operating under its current business name. Through the Invitation to Bid (ITB) process described herein, qualified Contractors interested in assisting the City with the provision of such services must prepare and submit a bid packet in accordance with the procedure and schedule of this ITB. The City will review submittals only from those contractors that submit an ITB packet which includes all the information required as described herein.

One of the following licenses is **required within bid submittal package**: State of Florida licensed Contractor or a Miami-Dade County Certified Engineering Contractor. The City will review submittals only from those contractors that submit an ITB packet which includes all the information required to be included as described herein; to stabilize a portion of the Dressel's Dairy Canal using geo-cell web technology.

The City intends to award a contract for Canal Bank Stabilization to the contractor that: possesses qualified man power, equipment, administrative capabilities to provide the proposed services, possesses previous experience on this type of work and provides the best offer and prices deemed to be in the greatest benefit to the City. In addition the Contractor must have previous experience in similar canal or river/stream bank restoration including utilization of geotextile or geo-web material for erosion control.

It is the intent of the City to award a contract for a period of **one hundred and twenty (120) calendar days** for final completion of project.

A copy of the complete bid package may be obtained from the City of Doral website, [www.cityofdoral.com](http://www.cityofdoral.com), by clicking on the Procurement Division link under City Departments. Select the "RFP/Open Bids" link. It is important that you click on the "register and download" hyperlink to access the entire document. Please note that a brief registration process is required prior to download. Once registered you will receive an activation code that will grant you access to the documents.

All questions or comments should be directed to the following email: [procurement@cityofdoral.com](mailto:procurement@cityofdoral.com). Inquiries must reference "***Canal Bank Stabilization Program: Year 5A Phase II, ITB No. 2020-23***" in the subject line. **No phone calls will be accepted in reference to this ITB.** Any communications regarding matters of clarification must be made in writing to the email address listed above. In the event that it become necessary to provide additional clarifying data or information that revises any part of this ITB, supplements or revisions will be made available via written addendum.

The City of Doral reserves the right to accept any bid deemed to be in the best interest of the City or to waive any informality in any bid. The City may reject any or all bids and re-advertise.

REMAINDER OF PAGE LEFT BLANK

## SCHEDULE OF EVENTS

Mandatory Pre-bid Conference:

10:00 am, July 7<sup>th</sup>, 2020

From your computer, tablet or smartphone.

<https://global.gotomeeting.com/join/248799237>

You can also dial in using your phone.

United States: +1 (669) 224-3412

Access Code: 248-799-237

Deadline for Written Questions:

5:00 pm, July 14<sup>th</sup>, 2020

Deadline for Submittal & Proposal Opening:

10:00 am, July 23<sup>rd</sup>, 2020

From your computer, tablet or smartphone.

<https://global.gotomeeting.com/join/874800109>

You can also dial in using your phone.

United States: +1 (786) 535-3211

Access Code: 874-800-109

END OF SECTION

# TABLE OF CONTENTS

## SCHEDULE OF EVENTS

SECTION 00200 – INSTRUCTIONS TO BIDDERS

SECTION 00300 – TRENCH SAFETY

SECTION 00410 – BID FORM

SECTION 00420 – AWARD PREFERENCE FOR IDENTICAL TIE BIDS

SECTION 00432 – BID BOND

SECTION 00434 – LIST OF PROPOSED SUBCONTRACTORS

SECTION 00450 – BIDDER QUALIFICATION STATEMENT

SECTION 00454 – NON-COLLUSION AFFIDAVIT

SECTION 00456 – PUBLIC ENTITY CRIMES

SECTION 00500 – CONSTRUCTION CONTRACT

SECTION 00510 – NOTICE OF AWARD

SECTION 00550 – NOTICE TO PROCEED

SECTION 00600 – BONDS AND CERTIFICATES

SECTION 00612 - FORM OF PAYMENT BOND

SECTION 00614 - FORM OF PERFORMANCE BOND

SECTION 00620 – ACKNOWLEDGMENT OF CONFORMANCE WITH OSHA STANDARDS

SECTION 00710 – GENERAL CONDITIONS

SECTION 00810 – SPECIAL CONDITIONS

STATEMENT OF NO RESPONSE

SOLICITATION RESPONSE FORM

GENEREAL INFORMATION WORKSHEET

BUSINESS ENTITY AFFIDAVIT (VENDOR/BIDDER DISCLOSURE)

AMERICANS WITH DISABILITIES ACT (ADA) DISABILITY NONDISCRIMINATION STATEMENT

PROPOSER'S CERTIFICATION

ITB SIGNATURE FOR SOLE PROPRIETOR OR PARTNERSHIP

ITB SIGNATURE PAGE FOR CORPORATION

## ATTACHMENTS:

Exhibit A – Insurance

Exhibit B – Change Order Form

Exhibit C – Construction Plans

Exhibit D- Section 02240 Stacked Bank Stabilization System

## SECTION 00200 - INSTRUCTIONS TO BIDDERS

IT IS THE RESPONSIBILITY OF THE BIDDER TO ENSURE THAT THE BID REACHES THE OFFICE OF THE CITY MANAGER ON OR BEFORE THE CLOSING HOUR AND DATE STATED ON THE INVITATION TO BID FORM.

**1.1 Taxes:** Bidder shall include all applicable taxes in the Bid.

**1.2 Purpose of Bid:** The City of Doral intends to secure a source of services/supply (s) at the lowest responsive and responsible price. The City reserves the right to award the Bid considered the best to serve the City's interests.

**1.3 Questions:** Any questions regarding this ITB should be directed in writing to the Procurement Division via email at: [procurement@cityofdoral.com](mailto:procurement@cityofdoral.com). All inquiries must have in the subject line the following: ***“Canal Bank Stabilization Program: Year 5A Phase II, ITB No.2020-23”***.

Bidders requiring clarification or interpretation of the ITB must submit them via e-mail on or before **5:00 pm, July 14<sup>th</sup>, 2020**. The person or firm submitting the request shall be responsible for its timely delivery. Written responses will be compiled and shall be issued only in addendum format and distributed to all potential Proposers listed on the official BIDDER's list as having received the bidding documents. In addition, inquiries and responses may also be posted on the City of Doral website and Demandstar. Only questions answered by written addenda shall be binding. Oral interpretations or clarifications shall be without legal effect. No plea of ignorance or delay or required need of additional information shall exempt a BIDDER from submitting their Bid on the required date and time as publicly noted.

**1.4 BIDDER** warrants that the prices, terms, and conditions quoted in the Bid will be firm for a period of 120 days from the date of the Bid opening unless otherwise stated in the Bid Form. Incomplete, unresponsive, irresponsible, vague, or ambiguous responses to the invitations to Bid will be cause for rejection, as determined by the City.

**1.5** Pursuant to the provisions of paragraph (2) (a) of section 287.133, Florida Statutes -"a person or affiliate who has been placed on the convicted vendor list following a conviction for a public entity crime may not submit a Bid on a contract to provide any goods or services to a public entity, may not submit a Bid on a contract with a public entity for the construction or repair of a public building or public work, may not submit bids on leases of real property to a public entity, may not be awarded to perform work as a contractor, supplier, subcontractor, or contractor under a contract with any public entity, and may not transact business with any public entity in excess of the threshold amount provided in section 287.107, for category two for a period of 36 months from the date of being placed on the convicted vendor list".

### **2.1 Submission of Bids**

**2.1.1** BIDDER's shall use the Bid Form(s) furnished by the City. Failure to do so may cause the Bid to be rejected. Removal of any of the Bid forms will invalidate the Bid. BIDDER

shall deliver to the City, as Bid package:

1. This entire Bid document, with all sections executed.
2. A copy of all issued addenda.
3. Bid Security, (Bid Bond from Surety Company) attached to the front inside cover of the Bid document.
4. Certificates of Competencies.
5. Certificate of Insurance and or Letter of Insurability

The entire Bid Package shall be placed in a sealed opaque envelope, box, or container and clearly marked with the BIDDER's name and address.

**2.1.2** Bids having an erasure or corrections must be initialed by the BIDDER in ink. Bids shall be signed in ink; all quotations shall be typewritten or printed and filled in with ink.

**2.1.3** Guaranties: No guarantee or warranty is given or implied by the City as to the total amount that may or may not be purchased from any resulting Contract or Award. These quantities are for bidding purposes only and will be used for tabulation and presentation of the Bid. The City reserves the right to reasonably increase or decrease quantities as required. The prices offered herein, and the percentage rate of discount applies to other representative items not listed in this Bid.

**2.2** Delivery: All items shall be delivered f.o.b. destination (i.e. at a specific City of Doral address), and delivery costs and charges (if any) will be included in the Bid Price. Exceptions shall be noted.

**2.3** Mistake: If there is a discrepancy in the unit and extended prices, the unit prices(s) will prevail and the extensions adjusted to coincide. Bidders are responsible for checking their calculations. Failure to do so will be at the Bidder's risk, and errors will not release the BIDDER from their responsibility as noted herein.

**3.1** Brand Names: If a brand name, make, of any "or equal" manufacturer trade name, or vendor catalog is mentioned whether or not followed by the words "approved equal" it is for the purpose of establishing a grade or quality of material only. Bidder may offer equals with appropriate identification, samples, and/or specifications on such item(s). The City shall be the sole judge concerning the merits of items Bid as equals.

**3.2** Material: Material(s) delivered to the City under this bid shall remain the property of the seller until accepted to the satisfaction of the City. In the event materials supplied to City are found to be defective or do not conform to specifications, the City reserves the right to return the product (s) to the seller at the sellers' expense.

**3.3** Pricing: Prices should be stated in units of quantity specified in the Bid Form. In case of a discrepancy, the City reserves the right to make the final determination at the lowest net cost to the City.

**3.4** Safety Standards: The BIDDER warrants that the product(s) supplied to the City conforms in all respects to the standards set forth in the Occupational Safety and Health Act (OSHA) and its



amendments. Bids must be accompanied by a materials data safety sheet (M.S.D.S.) when applicable.

**3.5 Payments:** Payment will be made after commodities/services have been received, accepted, and properly invoiced as indicated in the contract and/or purchase order. Invoices must bear the purchase order number.

**4.1 Liability, Insurance, Licenses & Permits:** where BIDDER's are required to enter onto City of Doral property to deliver materials or to perform work or services as a result of a Bid award, the BIDDER will assume the full duty, obligation, and expense of obtaining all necessary licenses, permits, inspections, and insurance required. The BIDDER shall be liable for any damages or loss to the City occasioned by negligence of the BIDDER (or their agent) or any person the BIDDER has designated in the completion of their contract as a result of the Bid. Contractor shall be required to furnish a certified copy of all licenses, certificates of competency or other licenser requirements necessary to practice their profession as required by Florida State Statute, Florida Building Code, Miami-Dade County, or City of Doral Code. Contractors shall include current Miami-Dade County Certificates of Competency. These documents shall be furnished to the City along with the Bid response. Failure to furnish these documents or to have required licenser will be grounds for rejecting the Bid and forfeiture of the Bid Bond.

**4.2** BIDDER shall furnish to the Finance Director, City of Doral, 8401 NW 53rd Terrace Doral, Florida 33166, certificate(s) of insurance which indicate that insurance coverage has been obtained from an insurance company authorized to do business in the State of Florida or otherwise secured in a manner satisfactory to the City, for those coverage types and amounts listed in Exhibit A - Insurance Requirements. At the time of Bid submission, the BIDDER must submit certificates of insurance.

**5.1** All insurance shall be issued by companies rated A-: Class V or better per A.M. Best's Key Rating Guide, latest edition and authorized to issue insurance in the State of Florida. It shall be the responsibility of the BIDDER and insurer to notify the finance support services director of the City of Doral of cancellation, lapse, or material modification of any insurance policies insuring the BIDDER, which relate to the activities of such vendor and the City of Doral. Such notification shall be in writing and shall be submitted to the City Finance Director thirty (30) days prior to cancellation of such policies. This requirement shall be reflected on the certificate of insurance.

**5.2** Failure to fully and satisfactorily comply with the City's insurance and bonding requirements set forth herein will result in the Rejection of the Bid by the City. The BIDDER hereby holds the City of Doral harmless and agrees to indemnify the City of Doral and covenants not to sue the City of Doral by virtue of such rejection.

**5.3** Copy rights and/or Patent Rights: BIDDER warrants that there has been no violation of copyrights or patent rights in manufacturing, producing or selling of goods shipped or ordered, as a result of this Bid. The bidder agrees to indemnify City from any and all liability, loss, or expense occasioned by any such violation.

**6.1** Warranty/Guaranty: Successful BIDDER shall take all necessary steps and complete all forms for Warranty / Guarantee coverage under this Contract. BIDDER warrants by signature on the Bid Form that prices quoted here are in conformity with the latest Federal Price Guidelines.

**6.2 Samples:** Samples of items, when required, must be furnished by the BIDDER free of charge to the City. Each individual sample must be labeled with the BIDDER's name and manufacturer's brand name and delivered by them within ten (10) calendar days of the Bid opening unless schedule indicates a different time. If samples are requested subsequent to the Bid opening, they should be delivered within ten (10) calendar days of the request. The City will not be responsible for returning samples.

**6.3 Governmental Restrictions:** In the event any governmental restrictions may be imposed which would necessitate alteration of the material quality, workmanship, or performance of the items offered on this Bid prior to their delivery, it shall be the responsibility of the successful BIDDER to notify the City at once, indicating in their letter the specific regulation which required an alteration. The City of Doral reserves the right to accept any such alteration, including any price adjustments occasioned thereby, or to cancel at no further expense to the City.

**6.4 Assignment:** The BIDDER shall not transfer or assign the performance required by this Bid without prior written consent of the City Manager. Any award issued pursuant to the Invitation to Bid and monies which may be due hereunder are not assignable except with prior written approval of the City Manager. Further, in the event that the majority ownership or control of the BIDDER changes hands subsequent to the award of this contract, BIDDER shall promptly notify CITY in writing of such change in ownership or control at least thirty (30) days prior to such change and CITY shall have the right to terminate the contract upon sixty (60) days written notice, at CITY's sole discretion.

**6.5 Award of Bids:** The City of Doral reserves the right to accept or reject any and / or all bids or parts of bids, to waive any informality, irregularities, or technicalities, to re-advertise for bids, or take any other actions that may be deemed to be in the best interests of the City. The City also reserves the right to award the Contract on a split order basis, group by group, or item by item, or such combination as will best serve the interests of the City, unless otherwise stated. The City also reserves the right to waive minor variations to the specifications (interpretation of such to be made by the applicable department personnel). Final determination and award of Bid(s) shall be made by the City Council. In addition, each bidder agrees to waive any claim it has or may have against the CITY, the Successful Bidder, and the respective employees, arising out of or in connection with the administration, evaluation, or recommendation of any bid.

**6.6 Discrepancies:** In case of discrepancies, computed dimensions shall govern over scaled dimensions; supplemental specifications shall govern over standard specifications; and special specifications shall govern over drawings, supplemental and standard specifications.

**7.1 Evaluation of Bids:** The City, at its sole discretion, reserves the right to inspect any / all BIDDER's facilities to determine their capability of meeting the requirements for the Contract. Also, price, responsibility, and responsiveness of the BIDDER, the financial position, experience, staffing, equipment, materials, references, and past history of service to the City and / or with other units of state, and / or local governments in Florida, or comparable private entities, will be taken into consideration in the Award of the Contract.

**7.2 Identical (tie bids):** Shall be awarded by the City in compliance with Florida State statutes

providing for a drug free workplace, that is, in the event of an identical tie Bid, a preference shall be given to a business having a drug free workplace under Florida Statute Section 287.087, as amended. Failure to provide proof of compliance when requested shall be cause for rejection of the Bid as determined by the City.

**7.3 Preference to Local Businesses:** No local preference for this ITB.

**7.4 Hold Harmless:** All BIDDERS shall hold the City, it's officials and employees harmless and covenant not to sue the City, it's officials and employees in reference to their decisions to reject, award, or not award a Bid, as applicable.

**7.5 Cancellation:** Failure on the part of the BIDDER to comply with the conditions, specifications, requirements, and terms as determined by the City, shall be just cause for cancellation of the Award.

**7.6 Disputes:** If any dispute concerning a question of fact arises under the Contract, other than termination for default or convenience, the BIDDER and the CITY department responsible for the administration of the Contract shall make a good faith effort to resolve the dispute. If the dispute cannot be resolved by agreement, then the department with the advice of the CITY Attorney shall resolve the dispute and send a written copy of its decision to the CONTRACTOR, which shall be binding on both parties.

**8.1 Non-conformance to Contract:** The City of Doral may withhold acceptance of, or reject items which are found upon examination, not to meet the specification requirements. Upon written notification of rejection, items shall be repaired to the City's satisfaction within (5) calendar days by the contractor at their own expense and redelivered at their expense. Rejected goods left longer than thirty (30) calendar days will be regarded as abandoned and the City shall have the right to dispose of them as its own property. Rejection for non-conformance or failure to meet delivery schedules may result in the Contractor being found in default.

**8.2 Default Provision:** In case of default by the BIDDER or CONTRACTOR, the City of Doral may procure the articles or services from other sources and hold the BIDDER or CONTRACTOR responsible for any excess costs occasioned or incurred thereby.

**8.3 Indemnification:** The CONTRACTOR shall indemnify, save harmless, and defend the City of Doral, its' officers, agents and employees from and against any claims, demands or causes of action of whatsoever kind or nature arising out of error, omission, negligent act, conduct, or misconduct of the CONTRACTOR, their agents, servants or employees in the provision of goods or the performance of services pursuant to this Bid and/or from any procurement decision of the City including without limitation, awarding the Contract to the CONTRACTOR.

**8.4 Secondary/Other Vendors:** The City reserves the right in the event the primary bidder cannot provide an item(s) or service(s) in a timely manner as requested, to seek other sources without violating the Contract.

**8.5 Specifications:** All construction and materials furnished by the successful BIDDER shall conform to the Standard and Specifications of the City of Doral, Miami-Dade County Public Works Department Standards and Specifications Parts 1, 2 & 3, The Manual of Uniform Minimum Standards for Design,

Construction and Maintenance for Streets and Highways, The Florida Department of Transportation Roadway and Traffic Design Standards, and the Florida Department of Transportation Standards and Specifications. BIDDER shall also perform all work in a safe manner, specifically, the rules and regulations of the Occupational Safety and Health Administration (OSHA) and the Manual of Uniform Traffic Control Devices (MUTCD) shall be strictly observed.

**8.6 Cone of Silence Provisions:** Notwithstanding any other provision of these specifications, the provisions of City "Cone of Silence" are applicable to this transaction. The "Cone of Silence," as used herein, means a prohibition on any communication regarding a particular Request for Proposal ("RFP"), Request for Qualification ("RFQ") or bid, between:

A potential vendor, service provider, proposer, bidder, lobbyist, or contractor, and:

The City Council, City's professional staff including, but not limited to, the City Manager and his or her staff, any member of the City's selection or evaluation committee.

The Cone of Silence shall be imposed upon each ITB, RFQ and bid after the advertisement of said ITB, RFQ, or bid.

The Cone of Silence shall terminate at the time the City Manager makes his or her written recommendation to the City Council. However, if the City Council refers the Manager's recommendation back to the Manager or staff for further review, the Cone of Silence shall be re-imposed until such time as the Manager makes a subsequent written recommendation.

The Cone of Silence shall not apply to:

- 1) oral communications at pre-bid conferences;
- 2) oral presentations before selection or evaluation committees;
- 3) public presentations made to the City Council during any duly noticed public meeting;
- 4) communication in writing at any time with any City employee, unless specifically prohibited by the applicable ITB, RFQ or bid documents. The bidder or proposer shall file a copy of any written communication with the City Clerk. The City Clerk shall make copies available to any person upon request;
- 5) communications regarding a particular ITB, RFQ or bid between a potential vendor, service provider, proposer, bidder, lobbyist or contractor and the City's Purchasing Agent or City employee designated responsible for administering the procurement process for such ITB, RFQ or bid, provided the communication is limited strictly to matters of process or procedure already contained in the corresponding solicitation document;
- 6) communications with the City Attorney and his or her staff;
- 7) duly noticed site visits to determine the competency of bidders regarding a particular bid during the time period between the opening of bids and the time the City Manager makes his or her written recommendation;
- 8) any emergency procurement of goods or services pursuant to City Code;

- 9) responses to the City's request for clarification or additional information;
- 10) contract negotiations during any duly noticed public meeting; and
- 11) communications to enable City staff to seek and obtain industry comment or perform market research, provided all communications related thereto between a potential vendor, services provider, proposer, bidder, lobbyist, or contractor and an member of the City's professional staff including, but not limited to, the City Manager and his or her staff are in writing or are made at a duly noticed public meeting.

Contact the City Attorney for any questions concerning Cone of Silence compliance.

Violation of the Cone of Silence by a particular bidder or proposer shall render any ITB award or RFQ award to said bidder or proposer voidable by the City Council and/or City Manager.

**8.7 Force Majeure :** It is understood that performance of any act by the City or Consultant hereunder may be delayed or suspended at any time while, but only so long as, either party is hindered in or prevented from performance by acts of God, the elements, war, rebellion, strikes, lockouts, epidemic, or any cause beyond the reasonable control of such party, provided however, the City shall have the right to provide substitute service from third parties or City forces as may be necessary to meet City needs. If the condition of force majeure exceeds a period of fourteen (14) days, the City may, at its option and discretion, cancel or renegotiate the agreement.

**9.1 Bonding Requirements:** The BIDDER, in submitting this Bid, must include a 5% Bid Bond for the amount of the base Bid. Such bond shall be from a **Surety Company** in the amount of 5% of the total amount of the base Bid. A company, cashier or personal check **shall not** be deemed a valid Bid Security.

**9.1.1 Performance and Payment Bond:** The City of Doral shall require the successful BIDDER to furnish a Performance Bond and Payment bond, each, in the amount of 100% of the total Bid Price, with the City of Doral as the Obligee, as security for the faithful performance of the Contract and for the payment of all persons performing labor or furnishing materials in connection herewith. The bonds shall be with a surety company authorized to do business in the State of Florida.

**9.1.2 Bid Guaranty:** The successful BIDDER shall execute the Contract (Agreement) and provide the required Performance Bond, Payment Bond, and Certificates of Insurance within ten (10) calendar days of notification of the award by the City.

The BIDDER who has the Contract awarded to them and who fails to execute the Contract, furnish the Performance and Payment Bonds, and/or Insurance Certificates within the specified time shall forfeit the Bid Security that accompanied their Bid, and the Bid Security shall be retained as liquidated damages by the City, and it is agreed that this sum is a fair estimate of the amount of damages the City will sustain in case the BIDDER fails to enter into the Contract and furnish the Bonds as herein before provided. Bid Security deposited in the form of a cashier's check drawn on a local bank in good standing shall be subject to the same

requirements as a Bid Bond.

**9.1.3 Contract Time and Contract Time Extensions:**

The time of completion of the work to be performed under this contract is the essence of the contract. Delays and extensions of time may be allowed only in accordance with the provisions stated in the appropriate section of the general conditions.

It is the intent of the City to award a contract for a period of **one hundred and twenty (120) calendar days** for final completion.

If applicable, the time allowed for the completion of the work shall be stated in each work order.

END OF SECTION

**SECTION 00500 - CONSTRUCTION CONTRACT**

This Contract (the "Contract") is dated as of the \_\_\_\_\_ day of \_\_\_\_\_ 20\_\_ by and between the City of Doral (hereinafter called the "CITY") and \_\_\_\_\_ (hereinafter called "CONTRACTOR") located at: \_\_\_\_\_.

CITY and CONTRACTOR, in consideration of the mutual covenants hereinafter set forth, agree as follows:

**ARTICLE 1 – WORK**

1.1 Project/Work: CONTRACTOR shall complete all Work as specified or indicated in the Contract Documents. The Work is generally described as the following: The Project consists of **Canal Bank Stabilization Program: Year 5A Phase II, ITB No.2020-23** all in accordance with the construction drawings.

**ARTICLE 2 – CITY’S REPRESENTATIVE, ARCHITECT AND ENGINEER**

2.1 It is understood that the CITY will designate a representative for the Work. The CITY’S REPRESENTATIVE referred to in any of the Contract Documents designated herein is **Carlos Arroyo, Public Works Director**, at City of Doral Government Center, 8401 NW 53<sup>rd</sup> Terrace Doral, Florida 33166.

2.2 The CITY’s ARCHITECT referred to in any of the Contract Documents designated herein is \_\_\_\_\_ N/A \_\_\_\_\_, \_\_\_\_\_ N/A \_\_\_\_\_.

2.3 The CITY’s ENGINEER referred to in any of the Contract Documents designated is **Carlos Ortega, P.E.**, at ADA Engineering, Inc., 8550 NW 33 Street, Doral, Florida 33122.

**ARTICLE 3 – TERM**

3.1 Contract Times. Contract Time will commence on the date the Agreement is executed and shall continue consequently for a period of **one hundred and twenty (120) calendar days**. Work shall be completed ("Final Completion") and shall be ready for final payment in accordance with the Contract Documents within thirty (30) calendar days from the date substantial completion is accepted

3.2 Term. This Contract shall not be effective until it is fully executed between the CITY and the CONTRACTOR. The term of the Contract shall be through the date of final payment unless terminated earlier pursuant to Section 00710 – General Conditions, Article 12, Suspension of Work and Termination.

3.3 Survival of Obligations. Any obligations by the CONTRACTOR, including but not limited to those set forth in Section 00710 – General Conditions, Article 13, Contractor’s General Warranty and Guarantee, that would or could occur after the date of expiration or termination of the Contract shall survive the termination or expiration of the Contract.

**3.4** Liquidated Damages. CITY and CONTRACTOR recognize that time is of the essence in this Contract and that the CITY will suffer financial loss if the Work is not completed within the contract times specified in Section 3.1 for the Work above, plus any approved extensions thereof allowed in accordance with the General Conditions. The CONTRACTOR also recognizes the delays, expense and difficulties involved in proving the actual loss suffered by CITY if the Work is not completed on time. Accordingly, instead of requiring any such proof, CITY and CONTRACTOR agree that as liquidated damages for delay (but not as a penalty) CONTRACTOR shall pay CITY **\$2,000.00** for each calendar day that expires after the time specified in Section 3.1 for Substantial Completion of the Work. After Final Completion, if CONTRACTOR shall neglect, refuse or fail to complete the remaining Work within the time specified in Section 3.1 for completion and readiness for final payment or any proper extension thereof granted by CITY, CONTRACTOR shall pay CITY **\$2,000.00** for each calendar day that expires after the time specified in Section 3.1 for completion and readiness for final payment.

**3.5** Should the Final Completion and acceptance of Work, together with any modification or additions, be delayed beyond the time for performance set in Section 3.1 above because of lack of performance by the CONTRACTOR, it is understood and agreed that aside from any other liquidated damages, all actual additional costs or losses incurred by the CITY including, but not limited to, completion contractor services, financing, professional services, unrealized revenue, will be the responsibility of the CONTRACTOR.

**3.6** Monies due to the CITY under Sections 3.4 and 3.5 shall be deducted from any monies due the CONTRACTOR, or if no money is due or the amount due is insufficient to cover the amount charged the CONTRACTOR shall be liable for said amount.

#### **ARTICLE 4 – CONTRACT PRICE**

**4.1** CITY shall pay CONTRACTOR for completion of the Work in accordance with the Contract Documents an amount in current funds equal to the sum of the amounts determined pursuant to this Article.

**4.1.1** For all Unit Price Work, an amount equal to the sum of the established unit price for each separately identified item of Unit Price Work times the estimated quantity of that item as indicated on the Unit Price Bid Form Section 00410. Estimated quantities are not guaranteed, and determination of actual quantities and classification are to be made by ENGINEER as provided in the Contract Documents.

**4.2** The CONTRACTOR agrees that all specific cash allowances are included in the above Contract Price and have been computed in accordance with the Contract Documents.

#### **ARTICLE 5 – PAYMENT PROCEDURES**

**5.1** CONTRACTOR shall submit Applications for Payment in accordance with the Section 00710 - General Conditions, Article 11, Payments to Contractor and Completion. Applications for Payment will be processed by CITY as provided in the General Conditions.

**5.2** Progress Payments, Retainage. CITY shall make progress payments, deducting the amount from the Contract Price above, on the basis of CONTRACTOR'S Applications for Payment as recommended by the CITY'S REPRESENTATIVE, on or about the last day of each month during



construction as provided herein. All such payments will be made in accordance with the schedule of values established in the General Conditions or, in the event there is no schedule of values, as provided in the General Conditions.

**5.2.1** No progress payment shall be made until CONTRACTOR delivers to the CITY complete original partial releases of all liens and claims signed by all Subcontractors, materialmen, suppliers, and vendors, indicating amount of partial payment, on a form approved by the CITY, and an affidavit that so far as the CONTRACTOR has knowledge or information, the releases include and cover all Materials and Work for which a lien or claim could be filed for work completed to date. CONTRACTOR shall also include red-line as-builts and an updated progress schedule.

**5.3** The CONTRACTOR agrees that ten percent (10%) of the amount due for Work as set forth in each Application for Payment shall be retained by CITY for each Progress Payment until Final Payment, as defined in Section 00710 - General Conditions, Article 11, Payments to Contractor and Completion.

**5.3.1** Prior to Substantial Completion, progress payments will be made in an amount equal to the percentage indicated above, but, in each case, less the aggregate of payments previously made and less such amounts as CITY'S REPRESENTATIVE shall determine, or CITY may withhold, in accordance with the General Conditions.

**5.4** The payment of any Application for Payment by CITY, including the Final Request, does not constitute approval or acceptance by CITY of any item of the Work in such Request for Payment, nor shall it be construed as a waiver of any of CITY's rights hereunder or at law or in equity.

**5.5** The Final Application for Payment by CONTRACTOR shall not be made until the CONTRACTOR delivers to the CITY complete original releases of all liens and claims signed by all Subcontractors, materialmen, suppliers, and vendors on a form approved by the CITY, and an affidavit that so far as the CONTRACTOR has knowledge or information, the releases include and cover all Materials and Work for which a lien or claim could be filed. The CONTRACTOR may, if any Subcontractor, materialmen, supplier or vendor refuses to furnish the required Final Waiver of Lien, furnish a bond satisfactory to CITY to defend and indemnify CITY and any other property owner, person or entity CITY may be required to indemnify against any lien or claim.

**5.6** Final Payment. Upon final completion and acceptance of the Work in accordance with the General Conditions, CITY shall pay the remainder of the Contract Price and any retainage as recommended by the CITY'S REPRESENTATIVE.

## **ARTICLE 6 – INSURANCE/INDEMNIFICATION.**

**6.1** Insurance. The CONTRACTOR shall secure and maintain throughout the duration of this Contract, insurance of such type and in such amounts necessary to protect its interest and the interest of the CITY against hazards or risks of loss as specified in the General Conditions of the Contract Documents.

**6.2** Indemnification. The CONTRACTOR shall indemnify, defend and hold harmless the CITY, their officials, agents, employees, and volunteers as set forth in General Conditions of the Contract Documents.

**ARTICLE 7 – CONTRACTOR’S REPRESENTATIONS.**

In order to induce CITY to enter into this Contract, CONTRACTOR makes the following representations:

**7.1** CONTRACTOR has examined and carefully studied the Contract Documents (including the Addenda) and the other related data identified in the Bidding Documents including “technical data.”

**7.2** CONTRACTOR has visited the site and become familiar with and is satisfied as to the general, local and site conditions that may affect cost, progress, performance or furnishing of the Work.

**7.3** CONTRACTOR is familiar with and is satisfied as to all federal, state and local Laws and Regulations that may affect cost, progress, performance and furnishing of the Work.

**7.4** CONTRACTOR has made, or caused to be made, examinations, investigations, tests, or studies as necessary to determine surface and subsurface conditions at or on the site. CONTRACTOR acknowledges that CITY does not assume responsibility for the accuracy or completeness of information and data shown or indicated in the Contract Documents with respect to underground facilities at or contiguous to the site. CONTRACTOR has obtained and carefully studied (or assumes responsibility for having done so) all such additional supplementary examinations, investigations, explorations, tests, studies and data concerning conditions (surface, subsurface and Underground Facilities) at or contiguous to the site or otherwise which may affect cost, progress, performance or furnishing of the Work or which relate to any aspect of the means, methods, techniques, sequences and procedures of construction to be employed by CONTRACTOR and safety precautions and programs incident thereto. CONTRACTOR does not consider that any additional examinations, investigations, explorations, tests, studies or data are necessary for the performance and furnishing of the Work at the Contract Price, within the Contract Times and in accordance with the other terms and conditions of the Contract Documents.

**7.5** The CONTRACTOR is aware of the general nature of Work to be performed by CITY and others at the site that relates to the Work as indicated in the Contract Documents.

**7.6** The CONTRACTOR has correlated the information known to CONTRACTOR, information and observations obtained from visits to the site, reports and drawings identified in the Contract Documents and all additional examinations, investigations, explorations, tests, studies and data with the Contract Documents.

**7.7** The CONTRACTOR has given the CITY’S REPRESENTATIVE written notice of all conflicts, errors, ambiguities or discrepancies that CONTRACTOR has discovered in the Contract Documents and the written resolution thereof by the CITY’S REPRESENTATIVE is acceptable to CONTRACTOR, and the Contract Documents are generally sufficient to indicate and convey understanding of all terms and conditions for performance and furnishing of the Work.

**7.8** The CONTRACTOR warrants the following:

**7.8.1 Anti-Discrimination:** The CONTRACTOR agrees that it will not discriminate against any employees or applicants for employment or against persons for any other benefit or service under this Contract because of race, color, religion, sex, national origin, or physical or mental handicap where the handicap does not affect the ability of an individual to perform in a position of employment, and to abide by all federal and state laws regarding non-discrimination.

**7.8.2 Anti-Kickback:** The CONTRACTOR warrants that no person has been employed or retained to solicit or secure this Contract upon an agreement or understanding for a commission, percentage, brokerage or contingent fee, and that no employee or officer of the CITY or any other applicable federal or state agency, has any interest, financially or otherwise, in the Project. For breach or violation of this warranty, the CITY shall have the right to annul this Contract without liability or, in its discretion, to deduct from the Contract Price or consideration, the full amount of such commission, percentage, brokerage or contingent fee.

**7.8.3 Licensing and Permits:** The CONTRACTOR warrants that it shall have, prior to commencement of work under this Contract and at all times during said work, all required licenses and permits whether federal, state, County or City.

**7.8.4 Public Entity Crime Statement:** The CONTRACTOR warrants that it has not been placed on the convicted vendor list following a conviction for public entity crime, as specified in Section 00456, of the Instructions to Bidders.

## **ARTICLE 8 – CONTRACT DOCUMENTS.**

**8.1** The Contract Documents listed below, which are listed in their order of precedence for the purpose of resolving conflicts, errors and discrepancies, by this reference shall become a part of the Contract as though physically attached as a part thereof:

**8.1.1** Change Orders.

**8.1.2** Field Orders.

**8.1.3** Contract for Construction.

**8.1.4** Exhibits to this Contract.

**8.1.5** Supplementary Conditions.

**8.1.6** General Conditions.

**8.1.7** Any federal, state, county or city permits for the Project

**8.1.8** Specifications bearing the title: (N/A)

**8.1.9** Drawings consisting of a cover sheet and inclusive of all sheets bearing the following general titles: **“Canal Bank Stabilization Program: Year 5A Phase II, ITB No. 2020-23”**

- 8.1.10** Bid Documents, including but not limited to: Addendum, Invitation to Bid, Instructions to Bidders, Bid Form provided by CONTRACTOR, Notice of Award and Notice to Proceed.
- 8.1.11** Addenda subject matter takes the same precedence of the respective subject matter that it is modifying. Furthermore, each subsequent addendum takes precedence over previous addenda.
- 8.1.12** The documents listed above shall be incorporated into this Contract (except as expressly noted otherwise above).
- 8.1.13** There are no Contract Documents other than those listed above in this Article. The Contract Documents may only be amended, modified or supplemented as provided in the General Conditions.
- 8.1.14** The Contract Documents shall remain the property of the CITY. The CONTRACTOR shall have the right to keep one record set of the Contract Documents upon completion of the Project; provided; however, that in no event shall the CONTRACTOR use, or permit to be used, any or all of such Contract Documents on other projects without the City's prior written authorization.
- 8.1.15** The General Conditions discuss the bond and surety requirements of the CITY. This Contract does [x], does not [ ] require bonds. If the Contract does not require bonds, the references to bonds in the General Conditions do not apply to this Contract.

**ARTICLE 9 – MISCELLANEOUS.**

**9.1** Terms used in this Contract which are defined in Article 1 of the General Conditions will have the meanings indicated in the General Conditions. Terms used in Article 1 of the Instructions to Bidders also apply to this Contract.

**9.2** Except as otherwise provided in the Contract Documents with respect to subcontractors, no assignment by a party hereto of any rights under or interests in the Contract Documents will be binding on another party thereto without the written consent of the party sought to be bound; and, specifically but without limitation, moneys that may become due and moneys that are due may not be assigned without such consent (except to the extent that the effect of this restriction may be limited by law), and unless specifically stated to the contrary in any written consent to an assignment no assignment will release or discharge the assignor from any duty or responsibility under the Contract Documents.

**9.3** CITY and CONTRACTOR each binds itself, its partners, successors, assigns and legal representatives to the other party hereto, its partners, successors, assigns and legal representatives in respect to all covenants, agreements and obligations contained in the Contract Documents.

**9.4** Severability. Should any provision, paragraph, sentence, word, or phrase contained in this Contract be determined by a court of competent jurisdiction to be invalid, illegal, or otherwise unenforceable under the laws of the State of Florida, such provision, paragraph, sentence, word, or

phrase shall be deemed modified to the extent necessary in order to conform with such laws, then shall be deemed severable, and in this Contract, shall remain unmodified and in full force and effect.

**9.5 Remedies.** If and when any default of this Contract occurs, the CITY may avail itself of any legal or equitable remedies that may apply, including, but not limited to, actual damages and specific performance. Such remedies may be exercised in the sole discretion of the CITY. Nothing contained in this Contract shall limit the CITY from pursuing any legal or equitable remedies that may apply.

**9.6 Access to Public Records.** The CONTRACTOR shall comply with the applicable provisions of Chapter 119, Florida Statutes. The CITY shall have the right to immediately terminate this contract for the refusal by the Contractor to comply with Chapter 119, Florida Statutes. The Contractor shall retain all records associated with this Contract for a period of five (5) years from the date of Final Payment or Termination of this Contract.

**9.7 Inspection and Audit.** During the term of this Contract and for five (5) years from the date of Termination, the CONTRACTOR shall allow CITY representatives access during reasonable business hours to CONTRACTOR’S records related to this Contract for the purposes of inspection or audit of such records. If upon an audit of such records, the CITY determines the CONTRACTOR was paid for services not performed, upon receipt of written demand by the CITY, the CONTRACTOR shall remit such payments to the CITY.

**9.8 Counterparts.** This contract may be signed in one or more counterparts, each of which when executed shall be deemed an original and together shall constitute one and the same instrument.

**9.9 Notices.** Whenever any party is required to give or deliver any notice to any other party, or desires to do so, such notices shall be sent via certified mail or hand delivery to:

FOR CITY:

Albert P. Childress, City Manager  
City of Doral  
8401 NW 53<sup>rd</sup> Terrace  
Doral, Florida 33166

WITH COPY TO:

Luis Figueredo, Esq.  
City Attorney  
City of Doral  
8401 NW 53<sup>rd</sup> Terrace  
Doral, Florida 33166

FOR CONTRACTOR:

\_\_\_\_\_  
\_\_\_\_\_  
\_\_\_\_\_  
\_\_\_\_\_

**9.10 WAIVER OF JURY TRIAL AND VENUE.** The CITY and CONTRACTOR knowingly, irrevocably, voluntarily and intentionally waive any right either may have to a trial by jury in State and or Federal court proceedings in respect to any action, proceeding, lawsuit or counterclaim based upon the Contract, arising out of, under, or in connection with the Work, or any course of conduct, course of dealing, statements or actions or inactions of any party. The venue for any lawsuit arising out of this Contract shall be in Miami-Dade County, Florida.

**9.11 Attorneys' Fees.** If either the CITY or CONTRACTOR is required to enforce the terms of the Contract by court proceedings or otherwise, whether or not formal legal action is required, the prevailing party shall be entitled to recover from the other party all such costs and expenses, including, but not limited to, court costs, and reasonable attorneys' fees at the trial and appellate level.

**9.12 Amendments.** This Contract may only be amended by the prior written approval of the parties or by execution of a Change Order in the form attached hereto as Exhibit "B".

IN WITNESS WHEREOF, the parties hereto have made and executed this Contract on the respective dates under each signature: THE CITY OF DORAL, FLORIDA, signing by and through its City Manager, authorized to execute same by Council action on the \_\_\_\_\_ day of \_\_\_\_\_, 20\_\_\_\_, and by \_\_\_\_\_(Contractor), signing by and through its \_\_\_\_\_, duly authorized to execute same.

WITNESS

CONTRACTOR

By: \_\_\_\_\_  
(Signature and Corporate Seal)

\_\_\_\_\_  
(Contractor)

\_\_\_\_\_  
(Print Name and Title)

\_\_\_\_\_  
(Signature)

\_\_\_\_\_  
(Print Name and Title)

\_\_\_\_\_ day of \_\_\_\_\_, 20\_\_\_\_\_.

ATTEST

CITY OF DORAL

\_\_\_\_\_  
Connie Diaz, City Clerk

\_\_\_\_\_  
Albert P. Childress, City Manager

APPROVED AS TO FORM AND LEGALITY FOR THE USE  
AND BENEFIT OF THE CITY OF DORAL ONLY:

\_\_\_\_\_  
Luis Figueredo, Esq., City Attorney

(\*) In the event that the Contractor is a corporation, there shall be attached to each counterpart a certified copy of a resolution of the board of the corporation, authorizing the officer who signs the contract to do so in its behalf.

**CERTIFICATE AS TO CORPORATE PRINCIPAL**

I, \_\_\_\_\_, certify that I am the \_\_\_\_\_ of \_\_\_\_\_ and that \_\_\_\_\_, who signed the Bid with the City of Doral, Miami-Dade County, Florida for \_\_\_\_\_, is \_\_\_\_\_ of said Corporation with full authority to sign said Bid on behalf of the Corporation.

Signed and sealed this \_\_\_\_ day of \_\_\_\_\_, 20\_\_.

(SEAL) \_\_\_\_\_  
Signature

\_\_\_\_\_  
Type Name and Title

STATE OF FLORIDA  
COUNTY OF MIAMI-DADE

SWORN TO AND SUBSCRIBED before me this \_\_\_\_ day of \_\_\_\_\_, 20\_\_.

My Commission Expires:

\_\_\_\_\_  
Notary Public



**CERTIFICATE AS TO AUTHORIZED CORPORATE PERSONNEL**

I, \_\_\_\_\_, certify that I am the \_\_\_\_\_ of \_\_\_\_\_, who signed the Bid with the City of Doral, Miami-Dade County, Florida, for the project titled \_\_\_\_\_, and that the following persons have the authority to sign payment requests on behalf of the Corporation:

---

(Signature) (Typed Name) (Title)

---

(Signature) (Typed Name) (Title)

---

(Signature) (Typed Name) (Title)

Signed and sealed this \_\_\_\_ day of \_\_\_\_\_, 20\_\_.

(SEAL) \_\_\_\_\_  
Signature

\_\_\_\_\_  
Type Name and Title

STATE OF FLORIDA  
COUNTY OF MIAMI-DADE

SWORN TO AND SUBSCRIBED before me this \_\_\_\_ day of \_\_\_\_\_, 20\_\_.

My Commission Expires:

\_\_\_\_\_  
Notary Public

**SECTION 00510 – NOTICE OF AWARD**

To: \_\_\_\_\_  
\_\_\_\_\_  
\_\_\_\_\_

PROJECT DESCRIPTION: City of Doral “**Canal Bank Stabilization Program: Year 5A Phase II, ITB No. 2020-23**” in accordance with Contract Documents as prepared by the City

and

The City has considered the Bid submitted by you for the above described WORK in response to its Advertisement for Bid and Instruction to BIDDERS.

You are hereby notified that your Bid has been accepted for the City of Doral “**Canal Bank Stabilization Program: Year 5A Phase II, ITB No. 2020-23**”, in a not to exceed amount of

\$ \_\_\_\_\_ Dollars.

You are required by the instruction to BIDDER’s to execute the Agreement and furnish the required CONTRACTOR’s Performance Bond, Payment Bond and Certificated of Insurance within ten (10) days from the date of this Notice to you.

If you fail to execute said Agreement and to furnish said Bonds and Insurance within ten (10) days from the date of this Notice, said City will be entitled to, revoke the award and retain the Bid Security.

By: \_\_\_\_\_

Title: City Manager

Dated this \_\_\_\_\_ day of \_\_\_\_\_, 20\_\_\_\_\_.

**ACCEPTANCE OF NOTICE OF AWARD**

Receipt of the above Notice of Award is hereby acknowledged by

\_\_\_\_\_

this the \_\_\_\_\_ day of \_\_\_\_\_, 20\_\_\_\_\_

By: \_\_\_\_\_

Title: \_\_\_\_\_

You are required to return an acknowledged copy of this Notice of Award to the City.

END OF SECTION

**SECTION 00550 – NOTICE TO PROCEED**

To: \_\_\_\_\_  
\_\_\_\_\_  
\_\_\_\_\_

Date: \_\_\_\_\_

PROJECT DESCRIPTION: **“Canal Bank Stabilization Program: Year 5A Phase II, ITB No. 2020-23”**, in accordance with Contract Documents as prepared by the City of Doral.

Site Number/Name: \_\_\_\_\_

Site Location: \_\_\_\_\_

You are hereby notified to commence all the work that conforms to the scope of work in accordance with the Contract Agreement dated \_\_\_\_\_. This work is to be completed in \_\_\_\_\_ calendar days, on or before \_\_\_\_\_, 20\_\_\_\_, with both parties being in total and full agreement or the Contractor shall be subject to the liquidated damages clauses of the Agreement. The cost to perform the scope of work in accordance with the Agreement shall not exceed \$\_\_\_\_\_.

City of Doral

By: \_\_\_\_\_

Albert P. Childress

Title: City Manager

**ACCEPTANCE OF NOTICE TO PROCEED**

Receipt of the above NOTICE TO PROCEED is hereby acknowledge by \_\_\_\_\_,

This \_\_\_\_\_ day of \_\_\_\_\_, 20\_\_\_\_\_.

By: \_\_\_\_\_

Title: \_\_\_\_\_

END OF SECTION

**SECTION 00600 - BONDS AND CERTIFICATES**

**SECTION 00612 - FORM OF PAYMENT BOND**

KNOW ALL MEN BY THESE PRESENTS:

That, pursuant to the requirements of Florida Statute 255.05, we, \_\_\_\_\_ as Principal, hereinafter called Contractor, and \_\_\_\_\_, as Surety, are bound to the City of Doral, Florida as Obligee, hereinafter called City, in the amount of Dollars (\$ \_\_\_\_\_ ) for the payment whereof Contractor and Surety bind themselves, their heirs, executors, administrators, successors and assigns, jointly and severally.

WHEREAS, Contractor has by written agreement entered into a Contract, ITB No. 2020-23, awarded the \_\_\_\_ day of \_\_\_\_\_, 20\_\_, with the City of Doral for "**Canal Bank Stabilization Program: Year 5A Phase II, ITB No.2020-23**" in accordance with specifications prepared by the City of Doral which Contract is by reference made a part hereof, and is hereafter referred to as the Contract;

THE CONDITION OF THIS BOND is that if the Contractor:

1. Indemnifies and pay Obligee all losses, damages (including, but not limited to, damages for delay (specifically, liquidated damages as per section 00710 – General Conditions of the ITB and section 3.4 of the Construction Contract) and actual damages caused or arising out of the acts, omissions or negligence of Contractor), expenses, costs, and attorney’s fees including attorney’s fees incurred in appellate proceedings, that Obligee sustain because of default by Contractor under the Contract; and
2. Promptly makes payments to all claimants as defined by Florida Statute 255.05(1) supplying Contractor with all labor, materials and supplies used directly or indirectly by Contractor in the prosecution of the Work provided for in the Contract, then this obligation shall be void; otherwise, it shall remain in full force and effect subject, however, to the following conditions:
  - 2.1 A claimant, except a laborer, who is not in privity with the Contractor and who has not received payment for their labor, materials, or supplies shall, within forty-five (45) days after beginning to furnish labor, materials, or supplies for the prosecution of the Work, furnish to the Contractor a notice that they intend to look to the Bond for protection.

- 2.2 A claimant who is not in privity with the Contractor and who has not received payment for their labor, materials, or supplies shall, within ninety (90) days after performance of the labor, or after complete delivery of the materials or supplies, deliver to the Contractor and to the Surety, written notice of the performance of the labor or delivery of the materials or supplies and of the non-payment.
- 2.3 No action for the labor, materials, or supplies may be instituted against Contractor or the Surety unless the notices stated under the preceding paragraphs 2.1 and 2.2 have been given.
- 2.4 Any action under this Bond must be instituted in accordance with the Notice and Time Limitations provisions prescribed in Section 255.05(2), Florida Statutes.

The Surety hereby waives notice of and agrees that any changes in or under the Contract Documents and compliance or noncompliance with any formalities connected with the Contract or the changes do not affect the Surety's obligation under this Bond.

Signed and sealed this \_\_\_\_\_ day of \_\_\_\_\_, 20\_\_.

WITNESS:

\_\_\_\_\_  
 \_\_\_\_\_

By: \_\_\_\_\_

(Signature and Title)

(CORPORATE SEAL)

\_\_\_\_\_  
 (Type Name and Title signed above)

WITNESS:

\_\_\_\_\_  
 (Name of Corporation)

\_\_\_\_\_

Secretary

By: \_\_\_\_\_

(Type Name and Title signed above)

IN THE PRESENCE OF;

INSURANCE COMPANY:

By: \_\_\_\_\_

\*Agent and Attorney-in-Fact

Address: \_\_\_\_\_

(Street) \_\_\_\_\_

(City/State/Zip Code) \_\_\_\_\_

Telephone No.: (\_\_\_\_) \_\_\_\_\_

\* (Power of Attorney must be attached)

State of \_\_\_\_\_

County of \_\_\_\_\_

On this, the \_\_\_\_\_ day of \_\_\_\_\_, 20\_\_, before me, the undersigned Notary Public of the State of \_\_\_\_\_, the foregoing instrument was acknowledged by (name of corporate officer), \_\_\_\_\_ (title), of (name of Corporation), a (state of corporation) corporation, on behalf of the corporation

WITNESS my hand

and official seal

\_\_\_\_\_

Notary Public, State of

\_\_\_\_\_



Printed, typed or stamped name of Notary  
Public exactly as commissioned

Personally known to me, or

Produced identification: \_\_\_\_\_

(type of identification produced)

Did take an oath, or

Did not take an oath

CERTIFICATE AS TO CORPORATE PRINCIPAL

I, \_\_\_\_\_, certify that I am the Secretary of the Corporation named as Principal in the foregoing Payment Bond; that \_\_\_\_\_, who signed the Bond on behalf of the Principal, was then \_\_\_\_\_ of said corporation; that I know his/her their signature; and his/her their signature thereto is genuine; and that said Bond was duly signed, sealed and attested to on behalf of said Corporation by authority of its governing body.

(CORPORATE SEAL)

\_\_\_\_\_

(Name of Corporation)

END OF SECTION

**SECTION 00614 - FORM OF PERFORMANCE BOND**

KNOW ALL MEN BY THESE PRESENTS:

That, pursuant to the requirements of Florida Statute 255.05, we, \_\_\_\_\_, as Principal, hereinafter called Contractor, and \_\_\_\_\_, as Surety, are bound to the City of Doral, Florida, as Obligee, hereinafter called City, in the amount of \_\_\_\_\_ Dollars (\$ \_\_\_\_\_) for the payment whereof Contractor and Surety bind themselves, their heirs, executors, administrators, successors and assigns, jointly and severally.

WHEREAS, Contractor has by written agreement entered into a Contract, ITB No. 2020-23, awarded the \_\_\_\_\_ day of \_\_\_\_\_, 20\_\_\_\_, with City of Doral for "**Canal Bank Stabilization Program: Year 5A Phase II, ITB No. 2020-23**" in accordance with drawings (plans) and specifications which Contract is by reference made a part hereof, and is hereafter referred to as the Contract;

THE CONDITION OF THIS BOND is that if the Contractor:

1. Fully performs the Contract between the Contractor and the City for: "**Canal Bank Stabilization Program: Year 5A Phase II, ITB No.2020-23**" as scheduled after the date of Contract commencement as specified in the Notice to Proceed and in the manner prescribed in the Contract; and bid specifications.
2. Indemnifies and pay Obligee all losses, damages (including, but not limited to, damages for delay (specifically, liquidated damages as per section 00710 – General Conditions of the ITB and section 3.4 of the Construction Contract) and actual damages caused or arising out of the acts, omissions or negligence of Contractor), expenses, costs, and attorney’s fees including attorney’s fees incurred in appellate proceedings, that Obligee sustain because of default by Contractor under the Contract; and
3. Upon notification by the City of Doral, corrects any and all defective or faulty Work or materials which appear within ONE (1) YEAR.
4. Performs the guarantee of all Work and materials furnished under the Contract for the time specified in the Contract, then this Bond is void, otherwise it remains in full force.

Whenever Contractor shall be, and declared by City to be, in default under the Contract, the City having performed their obligations thereunder, the Surety may promptly remedy the default, or shall promptly:

- 4.1 Complete the Contract in accordance with its terms and conditions; or
- 4.2 Obtain a Bid or Bids for completing the Contract in accordance with its terms and conditions, and upon determination by Surety of the best, lowest, qualified, responsible and responsive BIDDER, or, if the City elects, upon determination by the

City, and Surety jointly of the best, lowest, qualified, responsible and responsive BIDDER, arrange for a Contract between such BIDDER and City, and make available as Work progresses (even though there should be a default or a succession of defaults under the Contract or Contracts of completion arranged under this paragraph) sufficient funds to pay the cost of completion less the balance of the Contract Price; but not exceeding, including other costs and damages for which the Surety may be liable hereunder, the amount set forth in the first paragraph hereof. The term "balance of the Contract Price." as used in this paragraph, shall mean the total amount payable by City of Doral to Contractor under the Contract and any amendments thereto, less the amount properly paid by City of Doral to Contractor.

No right of action shall accrue on this Bond to or for the use of any person or Corporation other than the City named herein.

The Surety hereby waives notice of and agrees that any changes in or under the Contract Documents and compliance or noncompliance with any formalities connected with the Contract or the changes do not affect Surety's obligation under this Bond.

Signed and sealed this \_\_\_\_\_ day of \_\_\_\_\_, 20\_\_.

WITNESSES: \_\_\_\_\_

(Name of Corporation) \_\_\_\_\_

By: \_\_\_\_\_

Secretary

(Signature and Title)

(CORPORATE SEAL)

\_\_\_\_\_

(Type Name & Title signed above)

IN THE PRESENCE OF:

INSURANCE COMPANY: \_\_\_\_\_

\_\_\_\_\_

By:

\*(Agent and Attorney-in-Fact)

\_\_\_\_\_

Address:

(Street)

\_\_\_\_\_

(City/State/Zip Code)

Telephone No.: ( \_\_\_\_\_ ) \_\_\_\_\_

\* (Power of Attorney must be attached)

State of \_\_\_\_\_

County of \_\_\_\_\_

On this, the \_\_\_\_\_ day of \_\_\_\_\_, 20\_\_, before me, the undersigned

Notary Public of the State of \_\_\_\_\_, the foregoing instrument was acknowledged by (name of Corporate officer), \_\_\_\_\_ (title), of \_\_\_\_\_ (name of Corporation), a \_\_\_\_\_ (state of corporation) corporation, on behalf of the corporation.

WITNESS my hand

and official seal

\_\_\_\_\_  
\_\_\_\_\_

Printed, typed or stamped name of Notary Public  
exactly as commissioned

Notary Public, State of \_\_\_\_\_

Personally known to me, or

Produced identification:

\_\_\_\_\_

(type of identification produced)

Did take an oath, or

Did not take an oath

\_\_\_\_\_

Bonded by: \_\_\_\_\_

**SECTION 00620  
ACKNOWLEDGMENT OF CONFORMANCE  
WITH OSHA STANDARDS**

To the City of Doral,

We ENCO, LLC, hereby  
acknowledge and

Prime Contractor

agree that we, as the Prime Contractor for City of Doral, **Canal Bank Stabilization Program: Year 5A Phase II**, as specified, have the sole responsibility for compliance with all the requirements of the Federal Occupational Safety and Health Act of 1970, and all State and local safety and health regulations, and agree to indemnify and hold harmless the City of Doral, against any and all liability, claims, damages losses and expenses they may incur due to the failure of:

see section 00434  
\_\_\_\_\_  
(Subcontractor's Names)

\_\_\_\_\_  
to comply with such act or regulation.

\_\_\_\_\_  
CONTRACTOR Wilson Sanchez

J. Salella Micalte  
\_\_\_\_\_  
ATTEST

BY:

END OF SECTION

## **SECTION 00710 – GENERAL CONDITIONS**

### **ARTICLE I – DEFINITIONS**

Wherever used in these General Conditions or in the other Contract Documents, the following terms shall have the meaning indicated which shall be applicable to both the singular and plural thereof:

**Acceptance:** By the CITY of the Work as being fully complete in accordance with the Contract Documents subject to waiver of claims.

**Agreement:** The written Agreement between the CITY and the CONTRACTOR covering the Work to be performed, which includes the Contract Documents.

**Addenda:** Written or graphic instruments issued prior to the Bid Opening which modify or interpret the Contract Documents, Drawings and Specifications, by addition, deletions, clarifications or corrections.

**Application for Payment:** The form furnished by the CITY which is to be used by the CONTRACTOR in requesting progress payments.

**Approved:** Means approved by the CITY.

**Bid:** The offer or proposal of the BIDDER submitted on the prescribed form setting forth the prices for the Work to be performed.

**BIDDER:** Any person, firm or corporation submitting a Bid for Work.

**Bonds:** Bid, Performance and Payment Bonds and other instruments of security, furnished by the CONTRACTOR and their surety in accordance with the Contract Documents and in accordance with the law of the State of Florida.

**Change Order:** A written order to the CONTRACTOR signed by the CITY authorizing an addition, deletion or revision in the Work, or an adjustment in the Contract Price or the Contract Time issued after execution of the Agreement.

**CITY:** City of Doral, 8401 NW 53<sup>rd</sup> Terrace Doral, Florida 33166.

**Contract Documents:** Contract Documents shall include Instruction to BIDDERS, CONTRACTOR's Bid, the Bonds, the Notice of Award, these General Conditions, Special Conditions, the Technical Specifications, Drawings and Modifications, Notice to Proceed, Invitation to Bid, Insurance Certificates, Change Orders and Acknowledgement of Conformance with the City of Doral.

**Contract Price:** The total moneys payable to the CONTRACTOR under the Contract Documents.



**Contract Time:** The number of calendar days stated in the Agreement for the completion of the Work.

**Contracting Officer:** The individual who is authorized to sign the contract documents on behalf of the City's governing body.

**CONTRACTOR:** The person, firm or corporation with whom the CITY has executed the Agreement.

**CONSULTANT:** The person, firm or corporation that is an authorized representative of the City of Doral.

**Day:** A calendar day of twenty-four (24) hours measured from midnight to the next midnight.

**Drawings:** The drawings which show the character and scope of the Work to be performed and which have been prepared or approved by the CONSULTANT and are referred to in the Contract Documents.

**Field Order:** A written order issued by the CITY which clarified or interprets the Contract Documents in accordance with Paragraph 9.2 or orders minor changes in the Work in accordance with Paragraph 10.2.

**Modifications:** (a) A written amendment of the Contract Documents signed by both parties, (b) a Change Order, (c) a written clarification or interpretation if issued by the CITY in accordance with Paragraph 9.2 or (d) a written order for minor change or alteration in the Work issued by the CITY pursuant to Paragraph 10.2. A modification may only be issued after execution of the Agreement.

**Notice of Award:** A written notice given by the CITY to the CONTRACTOR fixing the date on which the Contract Time will commence to run and on which the CONTRACTOR shall start to perform their obligations under the Contract Documents.

**Project:** The entire Project to be performed as provided in the Contract Documents.

**Construction Observer:** An authorized representative of the CITY assigned to observe the Work performed and materials furnished by the CONTRACTOR or such other person as may be appointed by the CITY as his representative. The CONTRACTOR shall be notified in writing of the identity of this representative.

**Shop Drawings:** All drawings, diagrams, illustrations, brochures, schedules and other data which are prepared by the CONTRACTOR, a Subcontractor, manufacturer, supplier, or distributor, and which illustrate the equipment, material or some portion of the work and as required by the Contract Documents.

Samples: Physical examples which illustrate materials, equipment or workmanship and establish standards by which the Work will be judged.

Specifications: Those portions of the Contract Documents consisting of written technical descriptions of materials, equipment, construction systems, standards and workmanship as applied to the Work.

Subcontractor: An individual, firm or corporation having a direct contract with the CONTRACTOR or with any other Subcontractor for the performance of a part of the Work at the site.

Substantial Completion: The date as certified by the CITY when the construction of the Project or a certified part thereof is sufficiently completed, in accordance with the Contract Documents, so that the Project or specified part can be utilized for the purposes which it was intended; or if there be no such certification, the date when final payment is due.

Supplier: Any person or organization who supplies materials or equipment for the Work, including that fabricated to a special design, but who does not perform labor at the site.

Surety: The corporate body which is bound with the CONTRACTOR and which engages to be responsible for the CONTRACTOR and their acceptance performance of the Work.

Work: Any and all obligations, duties and responsibilities necessary to the successful completion of the Project assigned to or undertaken by the CONTRACTOR under the Contract Documents, including all labor, materials, equipment and other incidentals, and the furnishing thereof.

Written Notice: The term "Notice" as used herein shall mean and include all written notices, demands, instructions, claims, approvals and disapprovals required to obtain compliance with Contract requirements. Written notice shall be deemed to have been duly served if delivered in person to the individual or to a member of the firm or to an officer of the corporation for whom it is intended, or to an authorized representative or such individual, firm, or corporation, or if delivered at or sent by registered mail to the last business address known to them who gives the notice. Unless otherwise stated in writing, any notice to or demand upon the CITY under this Contract shall be delivered to the CITY.

## **ARTICLE 2 – PRELIMINARY MATTERS**

### **Award:**

**2.1** The CITY reserves the right to reject any and all Bids at its sole discretion. Bids shall be awarded by the CITY to the lowest responsive and responsible BIDDER; after the CITY performs all necessary searches, inquiries, exploration, and analysis of the bids. No Notice of Award will be given until the CITY has conducted any investigation(s) as they deem necessary to establish the BIDDER's capability to perform the services as described in this CONTRACT, as substantiated by the required professional experience, client references, technical knowledge and qualifications; and sufficient labor and equipment to comply with the CITY's established standards, as well as the financial capability of the BIDDER to perform the Work in accordance with the Contract Documents to the satisfaction of the CITY within the time prescribed. The CITY reserves the right to reject the Bid of any BIDDER on the basis of these queries and investigations and who does not meet the CITY's satisfaction, even though the firm may possibly be the apparent lowest bidder. In analyzing Bids, the CITY will also take into consideration client references, past work experience and work product, proven ability to satisfactorily perform the manufacturing and installation of roadway directional signage to CITY standards; and alternate and unit prices if requested by the Bid form. If the Contract is awarded, the CITY will issue the Notice of Award and give the successful BIDDER a Contract for execution within ninety (90) days after opening of Bids. The CITY specifically reserves the right to award the Contract to a bidder who is not necessarily the lowest bidder on the basis of the results of these queries and investigation(s).

### **Execution of Agreement:**

**2.2** At least three counterparts of the Agreement, the Performance and Payment Bond, the Certificates of Insurance and such other Documents as required by the Contract Documents shall be executed and delivered by the CONTRACTOR to the CITY within ten (10) calendar days of receipt of the Notice of Award.

### **Forfeiture of Bid Security/Performance and Payment Bond:**

**2.3** Within ten (10) calendar days of being notified of the Award, the CONTRACTOR shall furnish a Performance Bond and a Payment Bond containing all the provisions of the Performance Bond and Payment Bond attached.

**2.3.1** Each Bond shall be in the amount of one hundred percent (100%) of the Contract Price guaranteeing to the City the completion and performance of the Work covered in such Contract as well as full payment of all suppliers, material man, laborers, of Subcontractors employed pursuant to this Project. Each Bond shall be with a Surety company meeting the qualifications of Sections 2.3.4, 2.3.5, and 2.3.6.

**2.3.2** Each Bond shall continue in effect for one and one half (1 ½) years after final completion and acceptance of the Work with the liability equal to one hundred percent (100%) of the Contract Sum. The Performance Bond shall be

conditioned that the CONTRACTOR will, upon notification by the CITY, correct any defective or faulty Work or materials which appear within one and a one half (1 ½) years after final completion of the Contract.

**2.3.3** Pursuant to the requirements of Section 255.05(1), Florida Statutes, the CONTRACTOR shall ensure that the Bond(s) referenced above shall be recorded in the public records of Dade County and Provide the CITY with evidence of such recording.

**2.3.4** Each Bond must be executed by a surety company authorized to do business in the State of Florida as a surety, having a resident agent in the State of Florida and having been in business with a record of successful continuous operation for at least five (5) years.

**2.3.5** The surety company shall hold a current certificate of authority as acceptable surety on federal bonds in accordance with the United States Department of Treasury Circular 570, current Revisions.

**2.3.6** The CITY will accept a surety bond from a company with a rating of A- or better.

**2.3.7** Failure of the successful BIDDER to execute and deliver the Agreement and deliver the required bonds and Insurance Certificates as stipulated in paragraph 2.2 shall be cause for the CITY to annul the Notice of Award and declare the Bid and any security therefore forfeited.

Contractor's Pre-Start Representation:

**2.4** The CONTRACTOR represents that they have familiarized themselves with, and assumes full responsibility for having familiarized themselves with the nature and extent of the Contract Documents, Work, locality, and with all local conditions and federal, State and local laws, ordinances, rules and regulations that may in any manner affect performance of the Work, and represents that they have correlated their study and observations with the requirements of the Contract Documents. The CONTRACTOR also represents that they have studied all surveys and investigations reports of subsurface and latent physical conditions referred to in the specifications and made such additional surveys and investigations as they deem necessary for the performance of the Work in the Contract Documents and that they have correlated the results of all such data with the requirements of the Contract Documents. Additional monies will not be paid, over and above the CONTRACT amount, in the event rock is encountered.

Commencement of Contract Time:

**2.5** The Contract Time will start on the date the Agreement is executed and will continue to run consecutively for the period of **one hundred and twenty (120) calendar days** after date specified in Notice to Proceed. Project shall be completed and ready for final payment in accordance with the Contract Documents within **one hundred and twenty (120) calendar days** after the date specified in the Notice to Proceed ("Final Completion").

No extension of time will be given unless stated in writing.

Starting the Project:

**2.6** The CONTRACTOR shall start to perform their obligations under the Contract Documents on the date stipulated in the Notice to Proceed (NTP) for each site. No Work shall be done at the site prior to the date on which the NTP commences to run, except with the written consent of the CITY. No work will be done on Saturday without written consent of the CITY or after the end of a normal business day unless prior approval is given by the CITY in writing. No work shall be permitted on Sundays or on national holidays.

Before Starting Contract:

**2.7** Before undertaking each part of the Work, the CONTRACTOR shall carefully study and compare the Contract Documents and check and verify pertinent figures shown thereon and all applicable field measurements which shall be approximate. The CONTRACTOR shall field verify utility locations and notify the CITY of any conflicts so that the conflict is avoided prior to beginning of construction. Any modifications to the proposed work, once construction has begun, will be at no cost to the CITY.

Schedule of Completion:

**2.8** Within five (5) days after delivery of the Notice to Proceed, the CONTRACTOR will submit to the City, a Schedule defining hours and/or days required to complete each section of work as outlined.

**2.9** Within five (5) days after delivery of the executed Agreement by the CITY to the CONTRACTOR, but before starting the Work, a preconstruction conference will be held to review the above schedules, and provide procedures for processing Applications for Payment, and to establish a working understanding between the parties as to the Project. Present at the conference will be the CITY representative, and the CONTRACTOR.

Liquidated Damages:

**2.10** Upon failure of the CONTRACTOR to complete the Work within the time specified for completion, (plus approved extensions if any) the CONTRACTOR shall pay to the CITY the sum of **TWO THOUSAND DOLLAR AND 00/100 (\$2,000.00)** for each calendar day that the completion of the Work is delayed beyond the time specified in the Contract for completion, as fixed and agreed liquidated damages and not as a penalty. Liquidated damages are hereby fixed and agreed upon between the parties, recognizing the impossibility of precisely ascertaining the amount of damages that will be sustained by the CITY as a consequence of such delay and both parties desiring to obviate any question of dispute concerning the amount of said damages and the cost and effect of the failure of the CONTRACTOR to complete the Contract on time. Regardless of whether or not a single Contract is involved, the above-stated liquidated damages shall apply separately to each portion of the Work for which a time of completion is given. The CITY shall have the right to deduct from and retain out moneys which may be then due or which may become due and payable to the CONTRACTOR, the amount of such liquidated damages, the CONTRACTOR shall pay in full such liquidated damages.

### **ARTICLE 3 – CORRELATION, INTERPRETATION AND INTENT OF CONTRACT DOCUMENTS**

**3.1** It is the intent of the Specifications to describe a complete Project to be delivered in accordance with the Contract Documents. The Contract Documents comprise the entire Agreement between the CITY and the CONTRACTOR. They may be altered only by a Modification.

**3.2** The Contract Documents are complementary; what is called for by one is as binding as if called for by all. If CONTRACTOR finds a conflict, error or discrepancy in the Contract Documents, they shall call it to the City’s attention in writing at once and before proceeding with the Work affected thereby; however, they shall not be liable to CITY or CONTRACTOR for their failure to discover any conflict, error or discrepancy in the Specifications or Drawings. The various Contract Documents shall be given precedence in case of conflict, error or discrepancy, as follows: Change Orders, Supplemental General Conditions, Agreement Modifications, Addenda, Special Conditions, Instructions to BIDDERS, General Conditions, Specifications and Drawings. If the requirements of other Contract Documents are more stringent than those of the Supplemental General Conditions, the more stringent requirements shall apply.

**3.3** The words “furnish” and “furnish and install”, “install”, and “provide” or words with similar meaning shall be interpreted, unless otherwise specifically stated, to mean “furnish and install complete in place and ready for service”.

**3.4** Miscellaneous items and accessories which are not specifically mentioned, but which are essential to produce a complete and properly operating installation, or usable structure or plant, providing the indicated function, shall be furnished and installed without change in the Contract Price. Such miscellaneous items and accessories shall be of the same quality standards, including material, style, finish, strength, class, weight and other applicable characteristics, as specified for the major component of which the miscellaneous item or accessory is an essential part, and shall be approved by the CITY before installation. The above requirement is not intended to include major components not covered by or inferable from the Drawings and Specifications.

**3.5** The Work of all trades under this Contract shall be coordinated by the CONTRACTOR in such manner as to obtain the best workmanship possible for the entire Project, and all components of the Work shall be installed or erected in accordance with the best practices of the particular trade.

### **ARTICLE 4 – AVAILABILITY OF LANDS SUBSURFACE CONDITIONS REFERENCE POINTS**

#### **Availability of Lands:**

**4.1** The CITY will furnish, as indicated in the Contract Documents, the lands upon which the Work is to be done, rights-of-way for access thereto, and such other lands which

are designed for the use of the CONTRACTOR. Easements for permanent structures or permanent changes in existing facilities will be obtained and paid for by the CITY unless otherwise specified in the Contract Documents.

## **ARTICLE 5 – INSURANCE**

**5.1** The CONTRACTOR shall provide and maintain in force until all the Work to be performed under this Contract has been completed and accepted by City (or for such duration as is otherwise specified hereinafter), the insurance coverage set forth: in Exhibit A titled Insurance Requirements.

**5.2** The CONTRACTOR agrees that if any part of the Work under the Contract is sublet, they will require the Subcontractor(s) to carry insurance as required, and that they will require the Subcontractor(s) to furnish to them insurance certificates similar to those required by the CITY in Section 5.1.

### **Cancellation and Re-Insurance:**

**5.3** If any insurance should be canceled or changed by the insurance company or should any insurance expire during the period of this contract, the CONTRACTOR shall be responsible for securing other acceptable insurance to provide the coverage specified in this section to maintain coverage during the life of this Contract.

**5.4** All deductibles must be declared by the CONTRACTOR and must be approved by the CITY. At the option of the CITY, either the CONTRACTOR shall eliminate or reduce such deductible or the CONTRACTOR shall procure a Bond, in a form satisfactory to the CITY, covering the same. The contractor is responsible for any and all deductibles, if applicable, following a loss.

## **ARTICLE 6 – CONTRACTOR’S RESPONSIBILITIES**

### **Concerning Subcontractors:**

**6.1** The CONTRACTOR will not employ any Subcontractor, against whom the CITY may have reasonable objection, nor will the CONTRACTOR be required to employ any Subcontractor who has been accepted by the CITY, unless the CITY determines that there is good cause for doing so.

**6.2** The CONTRACTOR shall be fully responsible for all acts and omissions of their Subcontractors and of persons and organizations directly or indirectly employed by them and of persons and organizations for whose acts any of them may be liable to the same extent that they are responsible for the acts and omissions of persons directly employed by them. Nothing in the Contract Documents shall create any contractual relationship between CITY and any Subcontractor or other person or organization having a direct contract with CONTRACTOR, nor shall it create any obligation on the part of CITY to pay or to see to payment of any persons due any Subcontractor or other person or organization, except as may otherwise be required by law. CITY may furnish to any Subcontractor or other person or organization, to

the extent practicable, evidence of amounts paid to the CONTRACTOR on account of specified Work done in accordance with the schedule values.

**6.3** The divisions and sections of the Specifications and the identifications of any Drawings shall not control the CONTRACTOR in dividing the Work among Subcontractors or delineating the Work performed by any specific trade.

**6.4** The CONTRACTOR agrees to bind specifically every Subcontractor to the applicable terms and conditions of the Contract Documents for the benefit of the CITY.

**6.4.1** Contractor shall provide a list of each subcontractor whom which they are in sub-contract with. Requested information as follows:

- a) Sub-Contractor Firm name
- b) Sub-Contractor address and contact information

**6.5** All Work performed for the CONTRACTOR by a Subcontractor shall be pursuant to an appropriate agreement between the CONTRACTOR and the Subcontractor.

**6.6** The CONTRACTOR shall be responsible for the coordination of the trades, Subcontractors, materials and men engaged upon their Work.

**6.6.1** The CONTRACTOR shall cause appropriate provisions to be inserted in all subcontracts relative to the Work to bind Subcontractors to the CONTRACTOR by the terms of these General Conditions and other Contract Documents insofar as applicable to the Work of Subcontractors, and give the CONTRACTOR the same power as regards to terminating any subcontract that the CITY may exercise over the CONTRACTOR under any provisions of the Contract Documents.

**6.6.2** The CITY will not undertake to settle any differences between the CONTRACTOR and their Subcontractors or between Subcontractors.

**6.6.3** If in the opinion of the CITY, any Subcontractor on the Project proves to be incompetent or otherwise unsatisfactory, they shall be promptly replaced by the CONTRACTOR if and when directed by the CITY in writing.

Laws and Regulations:

**6.7** The CONTRACTOR will give all notices and comply with all laws, ordinances, rules and regulations applicable to the Work. If the CONTRACTOR observes that the Specifications or Drawings are at variance therewith, they will give the CITY prompt written notice thereof, and any necessary changes shall be adjusted by an appropriate modification. If the CONTRACTOR performs any Work knowing it to be contrary to such laws, ordinances, rules and regulations, and without such notice to the CITY, they will bear all costs arising wherefrom; however, it shall not be their primary responsibility to make certain that the Drawings and Specifications are in accordance with such laws, ordinances, rules and regulations.



Taxes:

**6.8** Cost of all applicable sales consumers, use, and other taxes for which the CONTRACTOR is liable under the Contract shall be included in the Contract Price stated by the CONTRACTOR.

Safety and Protection:

**6.9** The CONTRACTOR will be responsible for initiating, maintaining and supervising all safety precautions and programs in connection with the **ROADWAY AND TRAFFIC DESIGN STANDARDS SERIES 600 TRAFFIC CONTROL THROUGH WORK ZONES** latest edition. They will take all necessary precautions for the safety of, and will provide the necessary protection to prevent damage, injury or loss to:

**6.9.1** All employees and other persons whom may be affected thereby; and

**6.9.2** All the Work and all materials or equipment to be incorporated therein, whether in storage on or off the work area, and

**6.9.3** Other property at the work area or adjacent thereto, including trees, shrubs, lawns, walks, pavements, roadways, structures and utilities not designated for removal, relocation or replacement in the course of construction.

**6.10** The CONTRACTOR will designate a OSHA Certified "Competent Person" at the site whose duty shall be the prevention of accidents.

**6.10.1** A "Competent Person" is an individual, designated by the employer, who is capable of identifying existing and predictable hazards in the surroundings or working conditions which are unsanitary, hazardous or dangerous to workers, and who is authorized to take prompt corrective measures to eliminate them. [29 CFR 1926.32(f)].

Under the Excavation standards, tasks performed by the competent person include:

- Classifying soil;
- Inspecting protective systems;
- Designing structural ramps;
- Monitoring water removal equipment; and
- Conducting site inspections.

Emergencies:

**6.11** In emergencies affecting the safety of persons or the Work or property at the site or adjacent thereto, the CONTRACTOR, without special instruction or authorization from the CITY, is obligated to act, at their discretion, to prevent threatened damage, injury or loss. They will give the CITY prompt written notice of any significant changes in the Work or deviations from the Contract Documents caused thereby. If the CONTRACTOR believes that additional Work done by them in an emergency which arose from causes beyond their control entitles them to an increase in the Contract Price or an extension of the Contract Time, they may make a claim therefore as provided in articles 11 and 12.

**6.12** The CONTRACTOR will also submit to the CITY for review, with such promptness as to cause no delay in Work, all samples and photographs required by the Contract Documents. All samples and photographs will have been checked by and stamped with the approval of the CONTRACTOR, identified clearly as to material, manufacturer, any pertinent catalog numbers and the use for which intended.

**6.13** At the time of each submission, the CONTRACTOR will in writing call the CITY'S attention to any deviations that the Photographs or sample may have from the requirements of the Contract Documents.

**6.14** The CITY will review with responsible promptness Photographs and Samples, but their review shall be only for conformance with the design concept of the Project and for compliance with the information given in the Contract Documents. The CONTRACTOR will make any corrections required by the CITY and will return the required number of corrected copies of Photographs and resubmit new samples until the review is satisfactory to the CITY.

**6.15** No Work requiring a Photograph or sample submission shall be commenced until the submission has been reviewed by the CITY. A copy of each Photograph and each approved sample shall be kept in good order by the CONTRACTOR at the site and shall be available to the CITY.

**6.16** The CITY'S review of Photographs or samples shall not relieve the CONTRACTOR from their responsibility for any deviations from the requirements of the Contract Documents unless the CONTRACTOR has in writing called the CITY'S attention to each deviation at the time of submission and the CITY has given written approval to the specific deviation, nor shall any review by the CITY relieve the CONTRACTOR from responsibility for supplying the plant material as specified.

Public Convenience and Safety:

**6.17** The CONTRACTOR shall, at all times, conduct the Work in such a manner as to insure the least practicable obstruction to public travel. The convenience of the general public and of the residents along and adjacent to the area of Work shall be provided for in a satisfactory manner, consistent with the operation and local conditions. Proper Maintenance of Traffic (MOT) devices shall be placed immediately adjacent to the Work, in a conspicuous position, at such locations as traffic demands. The MOT shall be designed as outlined in the latest edition of **ROADWAY AND TRAFFIC DESIGN STANDARDS SERIES 600**. At any time that streets are required to be closed or blocked, the CONTRACTOR shall notify law enforcement agencies before the street is closed and again as soon as it is opened. Access to fire hydrants and other fire extinguishing equipment shall be provided and maintained at all times.

Indemnification:

**6.18** In consideration of the separate sum of twenty-five dollars (\$25.00) and other valuable consideration, the CONTRACTOR shall indemnify, defend and save harmless the CITY, its officers, agents and employees, from or on account of any injuries or damages, received or

sustained by any person or persons during or on account of any operations connected with the construction of this Project, or by or in consequence of any negligence by or on account of any act or omission of the said CONTRACTOR or his Subcontractor, agents, servants or employees. The CONTRACTOR will indemnify, defend and hold harmless the CITY and their agents or employees from and against all claims, damages, losses and expenses including attorneys' fees arising out of or resulting from the performance of the Work, provided that any such claim damage, loss or expense (a) is attributable to bodily injury, sickness, disease or death, or to injury to or destruction of tangible property including the loss of use resulting wherefrom and (b) is caused in whole or in part by any negligent act or omission of the CONTRACTOR, Subcontractor, anyone directly or indirectly employed by any of them or anyone for whose acts any of them may be liable, regardless of whether or not it is caused by a party indemnified hereunder. In the event that a court of competent jurisdiction determines that Sec. 725.06 (2), F.S. is applicable to this Work, then in lieu of the above provisions of this section 6.18 the parties agree that CONTRACTOR shall indemnify, defend and hold harmless CITY, their officers and employees, to the fullest extent authorized by Sec. 725.06 (2) F.S., which statutory provisions shall be deemed to be incorporated herein by reference as if fully set forth herein.

**6.19** In the event that any action or proceeding is brought against CITY by reason of any such claim or demand, CONTRACTOR, upon written notice from CITY shall defend such action or proceeding by counsel satisfactory to CITY. The indemnification provided above shall obligate CONTRACTOR to defend at its own expense or to provide for such defense, at CITY'S option, any and all claims of liability and all suits and actions of every name and description that may be brought against CITY, excluding only those which allege that the injuries arose out of the sole negligence of CITY, which may result from the operations and activities under this Contract whether the construction operations be performed by CONTRACTOR, its Subcontractors or by anyone directly or indirectly employed by either.

**6.20** The obligations of the CONTRACTOR under Article 6 shall not extend to the liability of the CITY, their agents or employees arising out of (a) the preparation or approval of maps, drawings, opinions, reports, surveys, Change Orders, designs or specifications or (b) the giving of or the failure to give directions or instructions by the CITY, their agents or employees provided such giving of failure to give is the primary cause of injury or damage. These indemnification provisions shall survive the term of this Contract.

## **ARTICLE 7 – CITY'S RESPONSIBILITIES**

**7.1** The CITY will issue all communications to the CONTRACTOR.

**7.2** In cases of termination of employment of the CONTRACTOR, the CITY will appoint a CONTRACTOR, whose status under the Contract Documents shall be that of the former CONTRACTOR.

**7.3** The CITY will furnish the data required of them under the Contract Documents promptly.

**7.4** The CITY's duties in respect to providing lands and easements are set forth in Article 4.

## **ARTICLE 8 – CITY'S STATUS DURING CONSTRUCTION**

### **Measurements of Quantities:**

**8.1** All Work completed under the Contract will be measured by the CITY according to the United States Standard Measures. All linear surface measurements will be made horizontally or vertically as required by the item measured.

### **Rejecting Defective Work:**

**8.2** The CITY will have authority to disapprove or reject Work which is "defective" (which term is hereinafter used to describe Work that is unsatisfactory, faulty or defective, or does not conform to the requirements of the Contract Documents or does not meet the requirements of any inspection, test or approval referred to in Special Condition, or has been damaged prior to final acceptance) at CONTRACTOR's expense.

### **Shop Drawings, Change Orders and Payments:**

**8.3** In connection with the CITY's responsibility as to Shop Drawings and samples, see paragraphs 6.12 through 6.16, inclusive.

**8.4** In connection with the CITY'S responsibility for Change Orders, see Articles 9 and 10.

**8.5** In connection with the CITY'S responsibilities in respect of Application of Payment, etc., see Article 11.

### **Decisions on Disagreements:**

**8.6** The CITY will be the initial interpreter of the Construction Drawings and Technical Specifications.

### **Limitations on Consultant's Responsibilities:**

**8.7** The CITY will not be responsible for the construction means, methods, techniques, sequences or procedures, or the safety precautions and programs incident thereto.

**8.8** The CITY will not be responsible for the acts or omissions of the CONTRACTOR, or any Subcontractors, or any of their or their agents or employees, or any other person performing any of the Work.

## **ARTICLE 9 – CHANGES IN THE WORK**

**9.1** Without invalidating the Agreement, the CITY may, at any time or from time to time, order additions, deletions or revisions in the Work; these shall be authorized by Change

Orders. Upon receipt of a Change Order, the CONTRACTOR will proceed with the Work involved. All such Work shall be executed under the applicable conditions of the Contract Documents. As per Articles 11 and Article 12, all Change Orders that add or delete work, or increase or decrease Time, will most likely result in an adjustment to the Contract Price and Time accordingly. Any such changes will be reflected in the Change Order(s), which when signed by the CONTRACTOR, shall indicate an agreement of the parties therewith.

**9.2** The CITY may authorize minor changes or alterations in the Work not involving extra cost and not inconsistent with the overall intent of the Contract Documents. These may be accomplished by a Field Order. If the CONTRACTOR believes that any minor change or alteration authorized by the CITY entitles them to an increase in the Contract Price or extension of Contract Time, they may make a claim therefore as provided in Articles 11 and 12.

**9.3** Additional Work performed by the CONTRACTOR without authorization of a Change Order will not entitle CONTRACTOR to an increase in the Contract Price or an extension of the Contract Time, except in the case of an emergency as provided in paragraph 6.11 and except as provided in paragraph 10.2.

**9.4** The CITY will execute appropriate Change Orders prepared by the CITY covering changes in the Work, to be performed and Work performed in an emergency as provided in paragraph 6.11 and any other claim of the CONTRACTOR for a change in the Contract Time or the Contract Price which is approved by the CITY.

**9.5** It is the CONTRACTOR'S responsibility to notify his Surety of any changes affecting the general scope of the Work or change in the Contract Price or Contract Time and the amount of the applicable bonds shall be adjusted accordingly. The CONTRACTOR will furnish proof of such an adjustment to the CITY.

## **ARTICLE 10 – CHANGE OF CONTRACT PRICE**

**10.1** The Contract Price constitutes the total compensation payable to the CONTRACTOR for performing the Work. All duties, responsibilities and obligations assigned to or undertaken by the CONTRACTOR shall be at their expense without changing the Contract Price.

**10.2** (a) The CITY may, at any time, without written notice to the sureties, by written order designated or indicated to be a Change Order, make any change in the Work within the general scope of the Contract, including but not limited to changes:

- 1) in the specifications (including drawings and designs);
- 2) in the method or manner of performance of the Work;
- 3) in the CITY-furnished facilities, equipment, materials, services, or site; or

4) in directing acceleration in the performance of the Work.

(b) Except as herein provided, no order, statement, or conduct of the CITY shall be treated as a change under this clause or entitle the CONTRACTOR to an adjustment to the Contract Price or Time.

(c) If any change order under this clause causes an increase or decrease in the CONTRACTOR'S cost of, or the time required for, the performance of any part of the Work, under this Contract, whether or not changed by any order, the Contract Price and Time will be adjusted in writing by the same amount.

(d) If the CONTRACTOR intends to assert a claim for an adjustment in Contract Price or Time under this clause, he must, within ten (10) days after receipt of a written Change Order, submit to the CITY a written notice including a statement setting forth the general nature and monetary extent of such claim, and supporting data.

(e) No claim by the CONTRACTOR for an adjustment in Contract Price or Time hereunder shall be allowed if not submitted in accordance with this section or if asserted after final payment under this Contract.

**10.3** The value of any Work covered by a Change Order or of any claim for an increase or decrease in the Contract Price shall be determined in one of the following ways:

**10.3.1** By negotiated lump sum.

**10.3.2** On the basis of the cost of the Work, determined as provided in Sections 10.4 and 10.5, plus a mutually agreed upon fee to the CONTRACTOR to cover overhead and profit.

**10.4** The term cost of the Work means the sum of all direct costs necessarily incurred and paid by the CONTRACTOR in the proper performance of the Work. Except as otherwise may be agreed to in writing by CITY, such costs shall be in amounts no higher than those prevailing in Miami-Dade County, shall include only the following items and shall not include any of the costs itemized in Paragraph 10.5.

**10.4.1** Payroll costs for employees in the direct employ of CONTRACTOR in the performance of the Work described in the Change Order under schedules of job classifications agreed upon by CITY and CONTRACTOR. Payroll costs for employees not employed full time on the Work shall be apportioned on the basis of their time spent on the Work. Payroll costs shall be limited to: salaries and wages, plus the costs of fringe benefits which shall include social security contributions, unemployment, excise and payroll taxes, workers' compensation, health and retirement benefits, sick leave, vacation and holiday pay applicable thereto. Such employees shall include

superintendents and foremen at the site. The expenses of performing Work after regular working hours, on Sunday or legal holidays shall be included in the above only if authorized by CITY.

**10.4.2** Cost of all materials and equipment furnished and incorporated in the Work, including costs of transportation and storage, and manufacturers' field services required in connection therewith. All cash discounts shall accrue to CONTRACTOR unless CITY deposits funds with CONTRACTOR with which to make payments in which case the cash discounts, shall accrue to the CITY. All trade discounts, rebates and refunds, and all returns from sale of surplus materials and equipment shall accrue to CITY, and CONTRACTOR shall make provisions so that they may be obtained.

**10.4.3** Payments made by CONTRACTOR to the Subcontractors for Work performed by Subcontractors. If required by CITY, CONTRACTOR shall obtain competitive bids from Subcontractors acceptable to him and shall deliver such bids to CITY who will then determine which Bids will be accepted. If a Subcontract provides that the Subcontractor is to be paid on the basis of Cost of Work plus a fee, the cost of the Work shall be determined in accordance with paragraphs 10.4 and 10.5.

**10.4.4** Rentals of all construction equipment and machinery and the parts thereof whether rented from CONTRACTOR or others in accordance with rental agreements approved by CITY with the advice of CONTRACTOR, and the costs of transportation, loading, unloading, installation, dismantling and removal thereof - all in accordance with terms of said rental agreements. The rental of any such equipment, machinery or parts shall cease when the use thereof is no longer necessary for the Work.

**10.4.5** Sales, use or similar taxes related to the Work, and for which CONTRACTOR is liable, imposed by any governmental authority.

**10.4.6** Payments and fees for permits and licenses. Costs for permits and licenses must be shown as a separate item.

**10.4.7** The cost of utilities, fuel and sanitary facilities at the site.

**10.4.8** Minor expenses such as telegrams, long distance telephone calls, telephone service at the site, expressage and similar petty cash items in connection with the Work.

**10.4.9** Cost of premiums for additional Bonds and Insurance required solely because of changes in the Work, not to exceed two percent (2%) of the increase in the Cost of the Work.

**10.5** The term Cost of the Work shall not include any of the following:

**10.5.1** Payroll costs and other compensation of CONTRACTOR's officers, executives, principals (of partnership and sole proprietorships), general managers,

engineers, architects, estimators, lawyers, agents, expeditors, timekeepers, clerks and other personnel employed by CONTRACTOR whether at the site or in his principal or a branch office for general administration of the Work and not specifically included in the schedule referred to in subparagraph 10.4.1 - all of which are to be considered administrative costs covered by the CONTRACTOR's fee.

**10.5.2** Expenses of CONTRACTOR's principal and branch offices other than his office at the site.

**10.5.3** Any part of CONTRACTOR's capital expenses, including interest on CONTRACTOR's capital employed for the Work and charges against CONTRACTOR for delinquent payments.

**10.5.4** Cost of premiums for all bonds and for all insurance policies whether or not CONTRACTOR is required by the Contract Documents to purchase and maintain the same (except as otherwise provided in subparagraph 10.4.9).

**10.5.5** Costs due to the negligence of the CONTRACTOR, any Subcontractor, or anyone directly or indirectly employed by any of them or for whose acts any of them may be liable, including but not limited to, the correction of defective work, disposal of materials or equipment wrongly supplied and making good any damage to property.

**10.5.6** Other overhead or general expense costs of any kind and the costs of any item not specifically and expressly included in paragraph 10.4.

**10.6** The CONTRACTOR's fee which shall be allowed to the CONTRACTOR for their overhead and profit shall be determined as follows:

**10.6.1** In the event of an oversight or omission by the CONTRACTOR no compensation for overhead or profit will be provided; otherwise.

**10.6.2** A mutually acceptable firm fixed price; or if none can be agreed upon.

**10.6.3** A **ten percent (10%)** fixed fee based on the estimate of the various portions of the Cost of the Work.

**10.7** The amount of credit to be allowed by the CONTRACTOR to the CITY for any such change which results in a net decrease in cost will be the amount of the actual net decrease. When both additions and credits are involved in any one change, the net shall be computed to include overhead and profit, identified separately, for both additions and credit, provided however, the CONTRACTOR shall not be entitled to claim lost profits for any Work not performed.

**10.8** Whenever cost of any Work is to be determined pursuant to paragraphs 10.4 and 10.5, the CONTRACTOR will submit in form prescribed by CITY an itemized cost breakdown



together with supporting data.

## **ARTICLE 11 – PAYMENTS AND COMPLETION**

### **Payments to Contractor:**

**11.1** At least ten (10) days before each progress payment falls due (but not more often than once a month), the CONTRACTOR will submit to the CITY a partial payment estimate filled out and signed by the CONTRACTOR covering the Work performed during the period covered by the partial payment estimate and supported by such data as the CITY may reasonably require.

The CITY will within ten (10) days after receipt of each partial payment estimate, either indicate in writing their approval of payment and present the partial payment estimate to the CITY, or return the partial payment estimate to the CONTRACTOR, indicating in writing their reasons for refusing to approve payment. In the latter case, the CONTRACTOR may make the necessary corrections and resubmit the partial payment estimate. The CITY, will within thirty (30) days of presentation to them of any approved partial payment estimate, pay the CONTRACTOR a progress payment on the basis of the approved partial payment estimate. The CITY may retain ten percent (10%) of the amount of each payment until final completion and acceptance of all Work covered by the Contract Documents. On completion and acceptance of a part of the Work on which the price is stated separately in the Contract Documents, payment may be made in full, including retained percentages, less authorized deductions. Any interest earned on the retainage shall accrue to the benefit of the CITY.

**11.2** The CITY shall have the right to demand and receive from the CONTRACTOR, before he shall receive final payment, final releases of lien executed by all persons, firms or corporations who have performed or furnished labor, services or materials, directly or indirectly, used in the Work; inclusive of Final As-builts. Likewise, as a condition to receiving any progress payment, the CITY may require the CONTRACTOR to furnish partial releases of lien executed by all persons, firms and corporations who have furnished labor, services or materials incorporated into the Work during the period of time for which the progress payment is due, releasing such lien rights as those persons, firms or corporations may have for that period, red-line as-builts, progress schedule.

### **Contractor's Warranty of Title:**

**11.3** The CONTRACTOR warrants and guarantees that title to all Work, materials and equipment covered by an Application for Payment, whether incorporated in the Project or not, will have passed to the CITY prior to the making of the Application for Payment, free and clear of all liens, claims, security interest and encumbrances (hereafter in these General Conditions referred to as "Liens"); and that no Work, materials or equipment covered by an Application for Payment will have been acquired by the CONTRACTOR or by any other person performing the Work at the site or furnishing materials and equipment for the Project, subject to an agreement under which an interest therein or encumbrance thereon is retained by the seller or otherwise imposed by the CONTRACTOR or such other person.

### **Acceptance of Final Payment as Release:**

**11.4** The Acceptance by the CONTRACTOR of final payment shall be and shall operate as a release to the CITY and a waiver of all claims and all liability to the CONTRACTOR other than claims in stated amounts as may be specifically excepted by the CONTRACTOR for all things done or furnished in connection with the Work and for every act and neglect of the CITY and others relating to or arising out of this Work. Any payment, however, final or otherwise, shall not release the CONTRACTOR of their sureties from any obligations under the Contract Documents or the Performance Bond and Payment Bonds.

## **ARTICLE 12 – SUSPENSION OF WORK AND TERMINATION**

**12.1** The CITY may, at any time and without cause, suspend the Work or any portion thereof for a period of not more than ninety (90) days by notice in writing to the CONTRACTOR which shall fix the date on which Work shall be resumed. For suspensions longer than ninety (90) days, The CONTRACTOR will be allowed an increase in the Contract Price or an extension of the Contract Time, or both, directly attributable to any suspension if they make a claim therefore as provided in Articles 11 and 12.

### **Work During Inclement Weather:**

**12.2** No Work shall be done under these specifications except by permission of the CITY when the weather is unfit for good and careful Work to be performed. Should the severity of the weather continue, the CONTRACTOR upon the direction of the CITY, shall suspend all Work until instructed to resume operations by the CITY and the Contract Time pursuant to Section 12.7 shall be extended to cover the duration of the order.

### **City May Terminate:**

**12.3** If the CONTRACTOR is adjudged bankrupt or insolvent, or if they make a general assignment for the benefit of their creditors, or if a trustee or receiver is appointed for the CONTRACTOR or for any of their property, or if they file a petition to take advantage of any debtor's act, or to reorganize under bankruptcy or similar laws, or if they repeatedly fails to supply sufficient skilled workmen or suitable materials or equipment, or if they repeatedly fail to make prompt payments to Subcontractors or for labor, materials or equipment or they disregards laws, ordinances, rules, regulations or orders of any public body having jurisdiction, or if they disregard the authority of the CITY, or if they otherwise violate any provision of the Contract Documents, then the CITY may, without prejudice to any other right or remedy and after giving the CONTRACTOR and their surety seven (7) days written notice, terminate the services of the CONTRACTOR and take possession of the Project and of all materials, equipment, tools, construction equipment and machinery thereon owned by the CONTRACTOR, and finish the Work by whatever method they may deem expedient. In such case the CONTRACTOR shall not be entitled to receive any further payment until the Work is finished. If the unpaid balance of the Contract Price exceeds the direct and indirect costs of completing the Project, including compensation for additional professional services, such excess shall be paid to the CONTRACTOR. If such costs exceed such unpaid balance, the CONTRACTOR will pay the difference to the CITY. Such costs incurred by the CITY will be determined by the CITY and incorporated in a Change Order.

If after termination of the CONTRACTOR under this Section, it is determined by a court of

competent jurisdiction for any reason that the CONTRACTOR was not in default, the rights and obligations of the CITY and the CONTRACTOR shall be the same as if the termination had been issued pursuant to Section 12.5.

**12.4** Where the CONTRACTOR'S services have been so terminated by the CITY said termination shall not affect any rights of the CITY against the CONTRACTOR then existing or which may thereafter accrue. Any retention or payment of moneys by the CITY due the CONTRACTOR will not release the CONTRACTOR from liability.

**12.5** Upon seven (7) days written notice to the CONTRACTOR, the CITY may, without cause and without prejudice to any other right or remedy, elect to terminate the Agreement. In such case, the CONTRACTOR shall be paid for all Work executed and accepted by the CITY as of the date of the termination. No payment shall be made for profit for Work which has not been performed.

Removal of Equipment:

**12.6** In the case of termination of this Contract before completion for any cause whatever, the CONTRACTOR, if notified to do so by the CITY, shall promptly remove any part or all of his equipment and supplies from the property of the CITY. Should the CONTRACTOR not remove such equipment and supplies, the CITY shall have the right to remove them at the expense of the CONTRACTOR. Equipment and supplies shall not be construed to include such items for which the CONTRACTOR has been paid in whole or in part.

Contractor May Stop Work or Terminate:

**12.7** If, through no act or fault of the CONTRACTOR, the Work is suspended for a period of more than ninety (90) days by the CITY or under an order of court of other public authority, or the CONTRACTOR fails to act on any Application for Payment within thirty (30) days after it is submitted, or the CITY fails to pay the CONTRACTOR any sum approved by the CITY, within thirty (30) calendar days of its approval, and presentation, then the CONTRACTOR may, upon twenty (20) calendar days written notice to the CITY, terminate the Agreement. The CITY may remedy the delay or neglect within the twenty (20) calendar days time frame. If timely remedied by the CITY the Contract shall not be considered terminated. In lieu of terminating the Agreement, if the CITY has failed to act on an Application for Payment or the CITY has failed to make any payment as aforesaid, the CONTRACTOR may upon ten (10) calendar days notice to the CITY and the CONTRACTOR stop the Work until they have been paid all amounts then due. If the CONTRACTOR stops neither by default nor by non-payment from the CITY, the CONTRACTOR will be responsible for 100% of the difference between the total of his/her Bid and the second lowest Bid.

**ARTICLE 13 - CONTRACTOR'S GENERAL WARRANTY AND GUARANTEE**

**13.1** CONTRACTOR warrants and guarantees to CITY all Work shall be in accordance with the Contract Documents and will not be defective.

**13.2** CONTRACTOR'S obligation to perform and complete the Work in accordance with the Contract Documents shall be absolute. None of the following will constitute an acceptance of Work that is not in accordance with the Contract Documents or a release of CONTRACTOR'S obligation to perform the Work in accordance with the Contract Documents:

**13.2.1** Observations by CITY or CITY'S REPRESENTATIVE, based on the recommendation of the ARCHITECT or ENGINEER;

**13.2.2** Payment by CITY of any progress or final payment;

**13.2.3** The issuance of a certificate of Substantial Completion, certificate of Final Completion, or any payment related thereto by CITY;

**13.2.4** Use or occupancy of the Work or any part thereof by CITY;

**13.2.5** Any acceptance by CITY or any failure to do so;

**13.2.6** Any review and approval of a Submittal or the issuance of a notice of acceptability by the CITY'S REPRESENTATIVE;

**13.2.7** Any inspection, test, or approval by others; or

**13.2.8** Any correction of defective Work by CITY.

**13.3** Access to Work:

The CITY'S REPRESENTATIVE, ARCHITECT or ENGINEER and other representatives of CITY, testing agencies and governmental agencies with jurisdictional interests shall have access to the Work at reasonable times for their observation, inspecting and testing. CONTRACTOR shall provide proper and safe conditions for such access.

**13.4** Tests and Inspection:

**13.4.1** CONTRACTOR shall give CITY timely notice of readiness of the Work for all required inspections, tests, observations or approvals. Inspections, tests or observations by the CITY'S REPRESENTATIVE, the ARCHITECT or ENGINEER, CITY or its agents may be performed at its discretion to provide information to the CITY on the progress of the Construction. However, such information is not intended to fulfill the CONTRACTOR'S obligations in accordance with the Contract Documents.

**13.4.2** CONTRACTOR shall assume full responsibility, pay all costs in connection therewith and furnish CITY the required certificates of inspection, testing or

approval for all materials, equipment or the Work or any part thereof unless otherwise specified herein.

**13.5 Uncovering the Work:**

If any Construction that is to be inspected, tested or approved is covered without written concurrence of CITY'S REPRESENTATIVE, it must, if requested by CITY or the CITY'S REPRESENTATIVE, be uncovered for observation. Such uncovering shall be at CONTRACTOR'S expense and will exclude the right to an increase in the Contract Price or Contract Time unless CONTRACTOR has given CITY or the CITY'S REPRESENTATIVE timely written notice of CONTRACTOR'S intention to cover such Construction and CITY or the CITY'S REPRESENTATIVE has not acted with reasonable promptness in response to such notice.

**13.5.1** If CITY considers it necessary or advisable that covered Work be observed by CITY'S REPRESENTATIVE or the ARCHITECT or ENGINEER, or inspected or tested by others, CONTRACTOR, at CITY'S request, shall uncover, expose or otherwise make available for observation, inspection or testing as CITY may require, that portion of the Work in question, furnishing all necessary labor, material and equipment. If it is found that such Work is defective, CONTRACTOR shall bear all the expenses of such uncovering, exposure, observation, inspection and testing and of satisfactory reconstruction, including compensation for additional professional services and any additional expenses experienced by the CITY due to delays to others performing additional work, other contractual obligations, and CITY shall be entitled to issue an appropriate deductive Change Order. CONTRACTOR shall further bear the responsibility for maintaining the schedule and will not be allowed an increase in Contract Price or Contract Time due to the uncovering. If, however, such Construction is not found to be defective, and Section 00700.8.5 is not applicable, CONTRACTOR shall be allowed an increase in the Contract Price or the Contract Time, or both, directly attributable to such uncovering, exposure, observation, inspection, testing and reconstruction if it makes a claim therefore as provided in the Contract Documents.

**13.6 CITY May Stop the Work:**

If the Work is defective, or CONTRACTOR fails to supply sufficient skilled workers or suitable materials or equipment, or fails to furnish or perform the Work in such a way that the completed Work will conform to the Contract Documents, CITY may order CONTRACTOR to stop the Work, or any portion thereof, until the cause for such failure has been eliminated; however, this right of CITY to stop the Work shall not give rise to any duty on the part of CITY to exercise this right for the benefit of CONTRACTOR or any other party. CONTRACTOR shall not be allowed an increase in Contract Price or the Contract Time or both as a result of the stopping of Work under this section.

**13.7 Correction or Removal of Defective Work:**

If required by the CITY'S REPRESENTATIVE, with the recommendation of the ARCHITECT and/or ENGINEER, CONTRACTOR shall promptly, as directed, either correct

all defective Work, whether or not fabricated, installed or completed, or, if the Work has been rejected by the CITY'S REPRESENTATIVE, upon the recommendation of the ARCHITECT or ENGINEER, remove it from the site and replace it with non-defective Work. CONTRACTOR shall bear all direct, indirect and consequential costs of such correction or removal (including but not limited to fees and charges of the CITY'S REPRESENTATIVE, the ARCHITECT or ENGINEER, attorneys and other professionals) made necessary thereby.

**13.8** One Year Correction Period:

Without prejudice to any other right of the City, if within one (1) year after the date of final completion or within any designated manufacturer's warranty, whichever is greater, or such longer period of time as may be prescribed by laws or regulations or by the terms of any applicable special guarantee required by the Contract Documents or by any specific provision of the Contract Documents, any Work is found to be defective, CONTRACTOR shall promptly, without cost to CITY and in accordance with CITY'S written instructions, either correct such defective Work, or, if it has been rejected by CITY or the CITY'S REPRESENTATIVE, based on the recommendation of the ARCHITECT or ENGINEER, remove it from the site and replace it with non-defective Work. If CONTRACTOR does not promptly comply with the terms of such instructions, or in an emergency where delay would cause serious risk of loss or damage, CITY may have the defective Work corrected or the rejected Work removed and replaced, and all of the CITY'S direct, indirect and consequential costs of such removal and replacement (including but not limited to fees and charges of the ARCHITECT or ENGINEER) will be reimbursed by CONTRACTOR. In special circumstances where a particular item of equipment is placed in continuous service before Substantial Completion of all the Work, the correction period for that item may start to run from an earlier date if so provided in the Specifications or by written amendment.

**13.9** CITY shall reserve and retain all of its rights and remedies at law and equity against CONTRACTOR and its surety for damages and for corrections of any and all latent defects.

**13.10** Extended Warranty Period Due to Defective Construction:

Any defective Construction that is either corrected or rejected and replaced will be warranted and guaranteed for a period of one (1) year from the date of acceptance of such correction or removal and replacement, even if it had previously been corrected or replaced, in accordance with the provisions of this Article 12. If within such extended Warranty Period, the Work is once again found to be defective, CITY shall be entitled to all of CITY'S rights and remedies under this Article.

**ARTICLE 14 – MISCELLANEOUS**

**14.1** Whenever any provision of the Contract Documents requires the giving of written notice it shall be deemed to have been validly given if delivered in person to the individual or to a member of the firm or to an officer of the corporation for whom it is intended, or if delivered at or sent by registered or certified mail, postage prepaid, to the last business

address known to them who gives the notice.

**14.2** The Contract Documents shall remain the property of the CITY. The CONTRACTOR and the CONTRACTOR shall have the right to keep one record set of the Contract Documents upon completion of the Project.

**14.3** The duties and obligations imposed by these General Conditions, Special Conditions and Supplemental Conditions and the rights and remedies available hereunder, and, in particular but without limitation, the warranties, guarantees and obligations imposed upon CONTRACTOR and those in the Special Conditions and the rights and remedies available to the CITY and there under, shall be in addition to, and shall not be construed in any way as a limitation of, any rights and remedies available by law, by special guarantee or by other provisions of the Contract Documents.

**14.4** Should the CITY or the CONTRACTOR suffer injury or damage to its person or property because of any error, omission, or act of the other or of any of their employees or agents or others for whose acts they are legally liable, claim shall be made in writing to the other party within a reasonable time of the first observance of such in- jury or damage.

#### **ARTICLE 15 – WAIVER OF JURY TRIAL**

**15.1** The CITY and the CONTRACTOR knowingly, irrevocably voluntarily and intentionally waive any right either may have to a trial by jury in State or Federal Court proceedings in respect to any action, proceeding, lawsuit or counterclaim based upon the Contract Documents or the performance of the Work thereunder.

#### **ARTICLE 16 – ATTORNEYS FEES/JURISDICITON/VENUE/GOVERNING LAW**

**16.1** The Contract shall be construed in accordance with and governed by the law of the State of Florida.

**16.2** The parties submit to the jurisdiction of any Florida State or federal court in any action or proceeding arising out of or relating to the Contract. Venue of any action to enforce the Contract shall be in Dade County, Florida.

**16.3** If either the CITY or the CONTRACTOR is required to enforce the terms of the Contract by court proceedings, the prevailing party shall be entitled to recover from the other party all such costs and expenses, including, but not limited to, court costs, and reasonable attorney’s fees.

#### **ARTICLE 17 – PROJECT RECORDS**

**17.1** The CITY shall have right to inspect and copy during regular business hours at CITY’S expense, the books and records and accounts of CONTRACTOR which relate in any way to the Project, and to any claim for additional compensation made by CONTRACTOR, and to conduct

an audit of the financial and accounting records of CONTRACTOR which relate to the Project. CONTRACTOR shall retain and make available to CITY all such books and records and accounts, financial or otherwise, which relate to the Project and to any claim for a period of three (3) years following final completion of the Project. During the Project and the three (3) year period following final completion of the Project, the CONTRACTOR shall provide the CITY access to its books and records upon five (5) days written notice.

**ARTICLE 18 – SEVERABILITY**

**18.1** If any provision of the Contract or the application thereof to any person or situation shall to any extent, be held invalid or unenforceable, the remainder of the Contract, and the application of such provisions to persons or situations other than those as to which it shall have been held invalid or unenforceable shall not be affected thereby, and shall continue in full force and effect, and be enforced to the fullest extent permitted by law.

**ARTICLE 19 – INDEPENDENT CONTRACTOR**

**19.1** The CONTRACTOR is an independent CONTRACTOR under the Contract. Services provided by the CONTRACTOR shall be by employees of the CONTRACTOR and subject to supervision by the CONTRACTOR, and not as officers, employees, or agents of the CITY. Personnel policies, tax responsibilities, social security and health insurance, employee benefits, purchasing policies and other similar administrative procedures, applicable to services rendered under the Contract shall be those of the CONTRACTOR.

**ARTICLE 20 – TRENCH SAFETY ACT**

**20.1** The purpose and intention of the State of Florida “Trench Safety Act” is to provide for increased worker safety by requiring compliance with sufficient standards for trench safety when the excavation is in excess of five (5) feet deep.

END OF SECTION



## SECTION 00810 – SPECIAL CONDITIONS

### 8.1 Permit/Utilities:

The CONTRACTOR shall obtain all permits necessary to conduct this project. The cost of all permits should be included on the bid proposal. If more than 1 Acre of land is disturbed during construction the CONTRACTOR is responsible to obtain NPDES Stormwater permit coverage through the Florida Department of Environmental Protection (FDEP) Construction Generic Permit (CGP). Instructions to request and obtain a CGP can be found at: <http://www.dep.state.fl.us/water/stormwater/npdes/docs/cgp.pdf>. CONTRACTOR should submit the Notice of Intent (NOI) with the appropriate processing fees to the NPDES Stormwater Notices Center. CONTRACTOR must apply for permit coverage at least two days before construction begins. In addition, the CONTRACTOR shall clear utilities prior to conducting any work at each project site. CONTRACTOR shall adhere to any restrictions imposed by FPL for conducting work under power lines.

### 8.2 Hours of Work:

Contractor will perform work Monday through Friday, excluding City holidays, from 8:00 a.m. to 6:00 p.m. unless prior written approval is received from The City. The CONTRACTOR must comply with the CITY's Noise Ordinance, Ordinance No. 2006-23.

### 8.3 Disputes:

If any dispute concerning a question of fact arises under the Contract, other than termination for default or convenience, the CONTRACTOR and the CITY's responsible department for the administration of the Contract shall make good faith effort to resolve the dispute. If the dispute cannot be resolved by agreement, then the department with the advice of the City Attorney shall resolve the dispute and send a written copy of its decision to the CONTRACTOR, which shall be binding on both parties.

### 8.4 Default Provisions:

In case of default by the BIDDER or CONTRACTOR, the CITY procure the articles or services from other sources and hold the BIDDER or CONTRACTOR responsible for any excess costs occasioned or incurred thereby.

### 8.5 Assignment:

The CONTRACTOR shall not transfer or assign the performance required by this Bid without prior written consent of the City Manager. Any award issued pursuant to the Invitation to Bid and monies which may be due hereunder are not assignable except with prior written approval of the City Manager. Further, in the event that the majority ownership or control of the CONTRACTOR changes hands subsequent to the award of this Contract, the CONTRACTOR shall promptly notify the CITY in writing of such change in ownership or control at least thirty (30) days prior to such change and the CITY shall have the right to terminate the Contract upon sixty (60) days written notice, at the CITY's sole discretion.

**8.6 Secondary/Other Vendors:**

The CITY reserves the right in the event the primary vendor cannot provide an item(s) or service(s) in a timely manner as requested, to seek other sources without violating the intent of the Contract.

**8.7 Employees:**

The CONTRACTOR shall be responsible for the appearance of all working personnel assigned to the project (clean and appropriately dressed at all times). Personnel must be able to supply proper identification at all times.

All employees of the CONTRACTOR shall be considered to be at all times the sole employees of the CONTRACTOR, under the CONTRACTOR's sole direction, and not an employee or agent of the City of Doral. The CONTRACTOR shall supply competent, suitably qualified and capable employees and the CITY may require the CONTRACTOR to remove any employee it deems careless, incompetent, insubordinate or otherwise objectionable and whose presence on CITY property is not in the best interest of the CITY. The CITY shall not have any duty to implement or enforce such requirements.

Each employee of the CONTRACTOR shall be a citizen of the United States or an alien who has been lawfully admitted for permanent residence as evidenced by an Alien Registration Receipt Card. The CONTRACTOR agrees not to employ any person undergoing sentence of imprisonment except as provided by Public Law 89-176, September 10, 1965, (18 USC4082)(c)(2).

The "On Duty" supervisor must be able to adequately communicate with the City's representatives.

**8.8 Subcontractors, Suppliers and Others:**

Prior to the commencement of any work, the CONTRACTOR shall furnish, in writing to the CITY, the names of persons or entities (including those who are to furnish materials or equipment fabricated to a special design) proposed for each principal portion of the Work. The CITY shall notify the CONTRACTOR, in writing, of any proposed person or entity to which CITY has an objection. The CONTRACTOR shall not contract with a proposed person or entity to which the CITY has made an objection. The CONTRACTOR shall not change a Subcontractor, person or entity previously selected if the CITY makes objection to the change.

The CONTRACTOR shall be fully responsible to CITY for all acts and omissions of the CONTRACTOR, its employees, Sub-Contractors, suppliers, other persons directly or indirectly employed by its Sub-Contractors or suppliers, persons for whose acts any of them may be liable and any other persons or organizations performing or furnishing supplies under a direct or indirect Contract with the CONTRACTOR. Nothing in the Contract Documents shall create any contractual relationship between CITY and any such Sub- Contractor, supplier or other person or organization, nor shall it create any obligation on the part of CITY to pay or to cause the payment of any money due any Sub-Contractor, supplier, employee or agent except as may otherwise be

required by law.

All Work performed for the CONTRACTOR by a Sub-Contractor will be pursuant to an appropriate agreement between the CONTRACTOR and the Sub-Contractor which specifically binds the Sub-Contractor to all applicable terms and conditions of the Contract Documents for the benefit of the CITY.

**8.9 Protection:**

All work in fulfillment of this project shall be performed on CITY property or public right-of-way. No permission will be given to trespass on adjoining property.

If property (public or private) is damaged during construction or is removed for the convenience of the work, it shall be repaired or replaced at the expense of the CONTRACTOR in a manner acceptable to the City of Doral prior to the final acceptance of the work. Such property shall include but not be limited to: pavement, sidewalks, curbs, driveways, walls, fences, footings, building façade, underground utilities, sod, shrubs, water sprinklers, signs, and trees.

The CONTRACTOR shall notify the Public Works Department in writing of the site having pre-existing damage to sidewalks, curbs, facade, adjacent improvements, etc., before beginning work. Failure to do so shall obligate the CONTRACTOR to make repairs per above paragraph.

The CONTRACTOR shall be solely responsible for pedestrian and vehicular safety and control within the work site and shall provide the necessary warning devices, signage, barricades and ground personnel needed to give safety, protection, and warning to persons and vehicular traffic within the area. All safety devices must have suitable and sufficient lighting for the prevention of accidents.

The CONTRACTOR shall protect existing catch basins from sediment and debris with filter fabric while work is in progress. Filter fabric shall be removed after completion of work. Filter fabric must be cleaned periodically to avoid excessive accumulation of sediment and debris. Extreme care shall be taken when removing filter fabric to avoid sediments and debris from entering catch basin.

**8.10 Security:**

The CONTRACTOR is responsible for project security. The CONTRACTOR shall protect and secure the site, materials, and equipment from theft and damage, by whatever means deems effective, at the CONTRACTOR's cost.

Work site(s) must be protected properly in accordance with all Federal, State, County and Municipal laws and ordinances, at the end of each workday and weekends.

**8.11 Temporary Interruption:**

The CONTRACTOR shall notify the Public Works Director whenever it is necessary to temporarily interrupt any business activities, the CONTRACTOR shall notify the Owner or tenant or their designee prior to the interruption and again immediately before the service is resumed. Before disconnecting any underground or overhead utilities, the CONTRACTOR shall make similar arrangements for their disconnection with the Owner, tenant or their designee. The CONTRACTOR shall be responsible for any damage caused by the CONTRACTOR to such utilities, and shall restore them to service promptly as soon as the Work interruption has ended.

**8.12 Pricing:**

Prices should be stated in units of quantity specified in the Bid form. In case of a discrepancy, the CITY reserves the right to make the final determination at the lowest net cost to the CITY.

**8.13 Delivery:**

All items shall be delivered "Freight On Board" (F.O.B.) destination (i.e. at a specific City of Doral address), and delivery costs and charges (if any) shall be included in the Bid Price. Exceptions shall be noted.

**8.14 Payments:**

Payment will be made after commodities/services have been received, accepted, and properly invoiced as indicated in the contract and/or purchase order. Invoices must bear the purchase order number.

**8.15 Non-Conformance to Contract:**

The CITY may withhold acceptance of, or reject items which are found upon examination, not to meet the specification requirements. Upon written notification of rejections, items shall be removed within five (5) calendar days by the vendor at their own expense and redelivered at their expense. Rejected goods left longer than thirty (3) calendar days will be regarded as abandoned and the CITY shall have the right to dispose of them as its own property. Rejection for non-conformance or failure to meet delivery schedules may result in the CONTRACTOR being found in default.

**8.16 Materials:**

The CONTRACTOR warrants that all materials and equipment shall be of good quality and new, unless otherwise provided in the specifications and that the work will be free from defects whether patent or latent in nature. All materials and equipment shall be applied, installed, connected, erected, used, cleaned and conditioned in accordance with the instructions of the applicable supplier except as otherwise provided in the specifications.

**8.17 Storage of Materials:**

The CONTRACTOR shall store materials, at his expense, in areas approved by the CITY. The CONTRACTOR, at their own expense, shall maintain these areas in a clean, orderly condition so as not to cause a nuisance in the area. The CONTRACTOR

shall restore the storage area to its original or better condition, with all its appurtenances, in kind, to the satisfaction of the CITY, at the CONTRACTOR's discretion, if the CONTRACTOR chooses to stage material outside of the designated area, with prior approval from the CITY.

**8.18 Quality Control:**

Field Observations - Provide twenty-four (24) hour notification to the Architect/Engineer for all specified field observations, unless otherwise noted.

Inspection – Periodically the City may inspect the project for the purpose of assuring compliance with the specifications.

Dust Control – Contractor shall control dust by watering and sweeping at end of each workday or as directed by City Engineer. Dust control must meet City's satisfaction or City will control dust by whatever means deem necessary and Contractor shall pay all expenses incurred by the City associated with dust control.

**8.19 On-Site Survey/As-Built:**

The CONTRACTOR shall be responsible for survey work required for establishing proper layout, elevations and grades as noted on the plans. The CONTRACTOR shall provide the CITY with three (3) sets of certified as-built plans and a CD containing PDF copy of the As-Built drawings as well as the CAD files, at no additional cost to the CITY.

**8.20 Water Usage:**

All City potable water used during the project shall be metered through a hydrant meter or meters obtained from the Miami-Dade County Water and Sewer Department at the CONTRACTOR's expense.

**8.21 Salvageable Material:**

All salvageable material and/or equipment removed from the existing construction for which specific use, relocation or other disposal is not specifically noted on the Drawings or otherwise specified, will remain the property of the CITY and be turned over to the CITY. All material and/or equipment not in salvageable condition as determined by the CITY Representative must be disposed of by the CONTRACTOR. The actual storage site for salvageable material will be designated by the CITY.

**8.22 Disposal of Excavated Material and Debris:**

All excess excavated material and debris not required for backfill (unless otherwise noted), including broken pipe, sidewalks, curbs and other concrete items, together with all roots, boards and other debris are to be disposed of by the CONTRACTOR at an appropriate legal site, at no additional cost to the CITY.

The CONTRACTOR must at all times during the performance of the project keep the work site free and clear of all waste and debris to the CITY's satisfaction. All sand, grit, solids and other material, accumulated waste or surplus materials shall

be removed at the end of each workday.

The CONTRACTOR will have not more than 48-hour notice to clear work site of rubbish, debris and other work site materials and to restore or replace displaced or damaged property, if the CONTRACTOR fails to comply, the CITY may employ labor or equipment as it deems necessary to clear the site at the CONTRACTORS's expense.

**8.23 Equipment:**

All construction equipment necessary and required for construction of this project shall be on the construction site, in excellent working condition, before construction is permitted to start. The CONTRACTOR shall provide such tamping tools and equipment as are necessary for the proper compaction of the backfill material.

**8.24 Density Testing:**

Density tests shall be taken by an independent testing laboratory certified by the State of Florida and approved by the designated City representative and shall be paid for by Contractor, at no additional cost to the City. A compaction test, for both the base and subgrade, shall be performed for every section of new pavement and at least one (1) test for every 250 square yards of new pavement. In addition, density testing shall be performed for installation in swale areas at a frequency of one test per 50 feet of trench, or adjacent to newly installed inlets at the discretion of the City representative.

Compaction test reports of sub-grade and base rock shall be submitted for approval to the designated City representative prior to installation of final asphaltic wearing surface.

**8.25 Laboratory Tests:**

Except as otherwise provided, sampling and testing of all materials, and the laboratory methods and testing equipment required under these specifications shall be in accordance with the latest standards of the American Society for Testing Materials.

The CONTRACTOR shall furnish the required samples for testing without charge. The CONTRACTOR shall provide at least twenty-four (24) hour notice when requesting testing to be performed. In locations where corings are taken by the approved testing lab, the CONTRACTOR shall be responsible for plugging these core holes.

All material tests will be made by an independent testing laboratory that may be selected by the CITY. Excluding Density Testing, where tests indicate that materials are in accordance with specified requirements, the CITY shall bear the testing cost. When tests reveal that conditions or materials do not comply with the specifications, the cost of such tests shall be assessed against the CONTRACTOR.

**8.26 Notification to Residents:**

Contractor shall notify residents directly impacted by the project (including MOT), in writing, 72 hours prior to performing any work. Notification must include type of work to be performed; date work will begin and estimated completion date. In the event Contractor changes schedule or duration of work, Contractor must notify resident, in writing, of such changes. Contractor must provide a copy of all notifications to the City.

**8.27 Staging Area:**

**No staging site available for this project.** Contractor must use available space along the public right-of-way without impacting or permanently closing sidewalks and/or the roadway or provide documentation for contractor selected staging area prior to commencement of work. The staging site/area is the responsibility of the contractor and the contractor shall be responsible for the restoration of the area at no additional cost to the City. Staging site shall be protected and shall have erosion and sedimentation control measure such as silt fence, at no additional cost to the City.

END OF SECTION

## **EXHIBIT A INSURANCE REQUIREMENTS**

### **I. Commercial General Liability**

#### **A. Limits of Liability**

Bodily Injury & Property Damage Liability	
Each Occurrence	\$2,000,000
Policy Aggregate (Per Project)	\$4,000,000
Personal & Advertising Injury	\$1,000,000
Products & Completed Operations	\$2,000,000

#### **B. Endorsements Required**

City of Doral listed as an additional insured  
Contingent & Contractual Liability  
Premises and Operations Liability  
Primary Insurance Clause Endorsement  
Explosion, Collapse & Underground Hazard  
Waiver of Subrogation in favor of City

No limitation on the scope/timeframe of protection afforded to the City. Completed Operations must be applicable for a minimum of 3 years following completion of this contract.

No limitation on the scope of protection afforded to the City, its officials, employees, or volunteers.

### **II. Business Automobile Liability**

#### **A. Limits of Liability**

Bodily Injury and Property Damage	
Combined Single Limit	
Any Auto/Owned Autos or Scheduled Autos	
Including hired and Non Owned Autos	
Any One Accident	\$2,000,000

#### **B. Endorsements Required**

Employees are covered as Insureds  
City of Doral listed as an additional insured

### **III. Workers Compensation**

Statutory- State of Florida



## Employer's Liability

### A. Limits of Liability

\$1,000,000 for bodily injury caused by an accident, each accident

\$1,000,000 for bodily injury caused by disease, each employee

\$1,000,000 for bodily injury caused by disease, policy limit

Waiver of Subrogation in favor of the City of Doral.

Workers Compensation insurance must be provided for all persons fulfilling this contract, whether employed, contracted, temporary or subcontracted.

### III. Professional Liability (if applicable)

Licensed professional design work such as that provided by architects, engineers, etc. shall maintain professional liability or errors or omissions insurance with the following limits:

#### Limits of Liability

Each Claim	\$2,000,000
Policy Aggregate	\$2,000,000

If claims made, retro Date applies prior to contract inception.

Coverage is to be maintained and applicable for a minimum of 3 years following contract completion.

- V. **Umbrella/Excess Liability (Excess Follow Form)** can be utilized to provide the required limits. Coverage shall be "following form" and shall not be more restrictive than the underlying insurance policy coverages, including all special endorsements and City as Additional Insured status.

**Subcontractors' Compliance:** It is the responsibility of the contractor to ensure that all subcontractors comply with all insurance requirements.

All above coverage must remain in force and Certificate of Insurance on file with City without interruption for the duration of this agreement. Policies shall provide the City of Doral with 30 days' written notice of cancellation or material change from the insurer. If the policies do not contain such a provision, it is the responsibility of the Contractor to provide such notice within 10 days of the change or cancellation.

Certificate Holder: City of Doral, Florida  
8401 NW 53<sup>rd</sup> Terrace  
Doral, FL 33166

Certificates/Evidence of Property Insurance forms must confirm insurance provisions required herein. Certificates shall include Agreement, Bid/Contract number, dates, and other identifying references.

Insurance Companies must be authorized to do business in the State of Florida, and must be rated no less than "A-" as to management, and no less than "Class V" as to financial strength, by the latest edition of AM Best's Insurance Guide, or its equivalent.

Coverage and Certificates of Insurance are subject to review and verification by City of Doral Risk Management. City reserves the right but not the obligation to reject any insurer providing coverage due to poor or deteriorating financial condition. The City reserves the right to amend insurance requirements in order to sufficiently address the scope of services. These insurance requirements shall not limit the liability of the Contractor/Vendor. The City does not represent these types or amounts of insurance to be sufficient or adequate to protect the Contractor/Vendor's interests or liabilities, but are merely minimums.

**“EXHIBIT B”**  
**CHANGE ORDER FORM**



"For all the right reasons!"<sup>SM</sup>

**CHANGE ORDER FORM**

**To Contractor:** \_\_\_\_\_ **Change Order Number:** \_\_\_\_\_  
**Proposal Number:** \_\_\_\_\_

**Project Name:** \_\_\_\_\_  
**Project Number:** \_\_\_\_\_

The City and Contractor hereby agree to perform the changes to the work as shown on the revised plans approved on: \_\_\_\_\_ and/or the additional work as described on Proposal Number: \_\_\_\_\_, dated \_\_\_\_\_.

**PROPOSAL DESCRIPTION:**

\_\_\_\_\_

**Total Amount of this Change Order:** \_\_\_\_\_

The City and Contractor agree to modify the original Contract by the following CHANGE ORDER amount:

Original Contract Amount..... \_\_\_\_\_  
Net change by Previous authorized Change Orders..... \_\_\_\_\_  
Contract Amount prior to this Change Order..... \_\_\_\_\_  
Contract Amount will be (**increased**)(decrease)(unchanged) in the amount of..... \_\_\_\_\_  
New Contract Amount including this Change Order..... \_\_\_\_\_  
Contract Time will be (increased)(decreased)(**unchanged**) by..... \_\_\_\_\_

**ACCEPTANCE:** The above prices and specifications of the Change Order Proposal are satisfactory and are hereby accepted. \_\_\_\_\_ will perform the above stated work under the same terms and conditions as specified in original contract unless otherwise noted.

**Contractor Signature:** \_\_\_\_\_ **Date:** \_\_\_\_\_  
**Title:** \_\_\_\_\_

**Authorized CITY Signature:** \_\_\_\_\_ **Date:** \_\_\_\_\_  
**Title:** \_\_\_\_\_



# CITY OF DORAL

## PLANS FOR PROPOSED CANAL EMBANKMENT RESTORATION PROGRAM FISCAL YEAR 5 PHASE II

### INDEX OF SHEETS

SHT. No.	SHEET DESCRIPTION
1	COVER SHEET
2	GENERAL NOTES
3	LEGEND AND ABBREVIATIONS
4	SUMMARY OF QUANTITIES
5	KEY PLAN
6	<del>SURVEY CONTROL PLANS WEST (NOT INCLUDED IN THIS SET)</del>
7	SURVEY CONTROL PLANS EAST
8	<del>TYPICAL SECTIONS WEST (NOT INCLUDED IN THIS SET)</del>
9	<del>TYPICAL SECTIONS EAST (NOT INCLUDED IN THIS SET)</del>
10	TYPICAL SECTIONS EAST (PHASE II)
11-12	<del>DRESSELS CANAL WEST (NOT INCLUDED IN THIS SET)</del>
13-18	<del>DRESSELS CANAL EAST (NOT INCLUDED IN THIS SET)</del>
19-21	DRESSELS CANAL - EAST (PHASE II)
22-23	<del>DRESSELS CANAL WEST CROSS SECTIONS (NOT INCLUDED IN THIS SET)</del>
24-33	<del>DRESSELS CANAL EAST CROSS SECTIONS (NOT INCLUDED IN THIS SET)</del>
34-37	DRESSELS CANAL - EAST CROSS SECTIONS (PHASE II)
38-44	DETAILS
LA1-LA3	<del>TREE DISPOSITION PLANS (NOT INCLUDED IN THIS SET)</del>
LA4-LA5	TREE DISPOSITION PLANS
LA6-LA8	<del>PLANTING MITIGATION PLANS (NOT INCLUDED IN THIS SET)</del>
LA-9	PLANTING NOTES, SPECIFICATIONS, AND DETAILS

DRESSELS CANAL-WEST

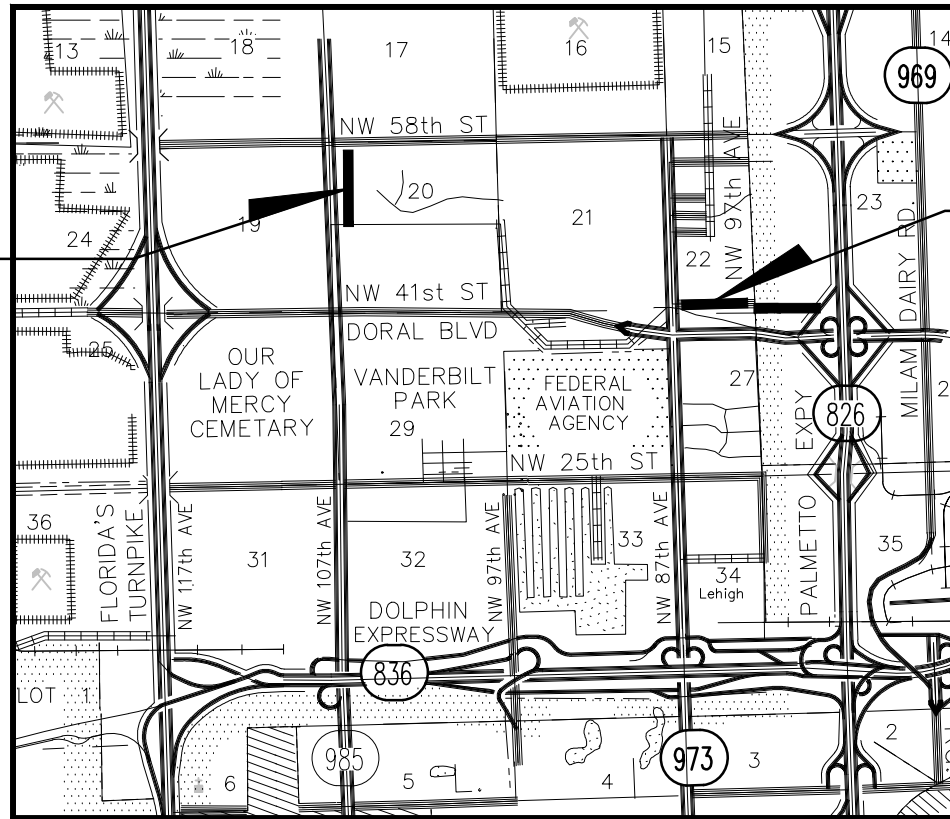

DRESSELS  
CANAL-EAST

CITY COUNCIL  
MAYOR  
JUAN CARLOS BERMUDEZ

VICE MAYOR  
CLAUDIA MARIACA

COUNCILWOMAN  
DIGNA CABRAL

COUNCILMAN  
PETE CABRERA

COUNCILWOMAN  
CHRISTI FRAGA

### LOCATION MAP

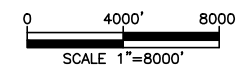

PREPARED FOR  
CITY OF DORAL  
PUBLIC WORKS DEPARTMENT

8300 NW 53rd STREET SUITE 202  
DORAL, FLORIDA 33166

PREPARED BY  
A.D.A. ENGINEERING, INC.



8550 NW 33rd STREET, SUITE 202  
DORAL, FLORIDA 33122

### NOTES:

1. THESE PLANS HAVE BEEN PREPARED IN ACCORDANCE WITH AND ARE GOVERNED BY THE CITY OF DORAL STANDARDS, MIAMI-DADE COUNTY PUBLIC WORKS DEPARTMENT STANDARDS AND SPECIFICATIONS PARTS 1, 2 AND 3, THE MANUAL OF UNIFORM MINIMUM STANDARDS FOR DESIGN, CONSTRUCTION AND MAINTENANCE FOR STREETS AND HIGHWAYS, THE FLORIDA DEPARTMENT OF TRANSPORTATION ROADWAY AND TRAFFIC DESIGN STANDARDS (CURRENT EDITION), AND THE FLORIDA DEPARTMENT OF TRANSPORTATION STANDARD SPECIFICATIONS FOR ROAD AND BRIDGE CONSTRUCTION DIVISIONS II AND III (CURRENT EDITION), AS AMENDED BY THE CONTRACT DOCUMENTS.
2. ATTENTION IS DIRECTED TO THE FACT THAT THESE PLANS MAY HAVE BEEN ENLARGED IN SIZE BY REPRODUCTION. THIS MUST BE CONSIDERED WHEN OBTAINING SCALED DATA.



ENGINEER OF RECORD:

JEFFREY VOLLAT  
FLORIDA REGISTRATION P.E. No. 63930

JUNE 2020

P:\Projects\173 City of Doral\0514\_Canal Bank Stabilization Program Management\01\_Year 5 Design\05\_Drawings\Year 5A - Phase II\02\_GEN\_YR-5.dwg Jun 11, 2020 - 3:51pm CORTECA

**GENERAL NOTES**

- ALL CONSTRUCTION AND MATERIALS SHALL CONFORM TO THE STANDARDS AND SPECIFICATIONS OF THE CITY OF DORAL, MIAMI-DADE COUNTY PUBLIC WORKS DEPARTMENT, FLORIDA DEPARTMENT OF TRANSPORTATION, SOUTH FLORIDA WATER MANAGEMENT DISTRICT (SFWMD), AND ALL OTHER LOCAL AND NATIONAL CODES WHERE APPLICABLE.
- ALL CONSTRUCTION SHALL BE PERFORMED IN A SAFE MANNER, SPECIFICALLY, THE RULES AND REGULATIONS OF THE OCCUPATIONAL SAFETY AND HEALTH ADMINISTRATION (OSHA) AND THE MANUAL OF UNIFORM TRAFFIC CONTROL DEVICES (MUTCD) SHALL BE STRICTLY OBSERVED.
- CONTRACTOR SHALL OBTAIN ALL NECESSARY PERMITS PRIOR TO COMMENCING CONSTRUCTION.
- UPON RECEIPT OF NOTICE OF AWARD AND AFTER OBTAINING AN ENGINEERING CONSTRUCTION PERMIT FROM APPLICABLE AGENCIES, THE CONTRACTOR SHALL ARRANGE A PRE-CONSTRUCTION CONFERENCE TO INCLUDE THE CITY OF DORAL, THE CITY PUBLIC WORKS DIRECTOR, AND THE ENGINEER OF RECORD.
- CONTRACTOR SHALL CONTACT SUNSHINE STATE ONE-CALL AT 1-(800)-432-4770 AT LEAST 48 HOURS PRIOR TO PERFORMING ANY DIGGING TO VERIFY THE EXACT LOCATION OF EXISTING UTILITIES. A CONTRACTOR'S REPRESENTATIVE MUST BE PRESENT WHEN UTILITY COMPANIES LOCATE THEIR FACILITIES.
- THE CONTRACTOR IS TO USE CAUTION WHEN WORKING IN OR AROUND AREAS OF OVERHEAD AND UNDERGROUND UTILITIES.
- EXISTING UNDERGROUND UTILITIES, IF SHOWN ON THE DRAWINGS, HAVE BEEN SHOWN BASED UPON THE BEST AVAILABLE INFORMATION. THE CONTRACTOR SHALL BE REQUIRED TO MARK AND CLEARLY DELINEATE LOCATIONS OF EXISTING UTILITIES WITHIN AREAS OF WORK PRIOR TO EXCAVATION TO AVOID DAMAGE. THE CONTRACTOR SHALL MAKE ALL REASONABLE EFFORTS TO LOCATE, IDENTIFY AND MARK EXISTING UTILITIES BY FIELD VERIFICATION, COORDINATION WITH UTILITY COMPANIES AND ELECTRONIC OR OTHER SUCH DETECTION TECHNOLOGY AND MEANS AND SHALL BEAR ALL COSTS FOR THIS WORK.
- AS-BUILT INFORMATION FOR ALL UTILITIES WAS NOT AVAILABLE AT THE TIME OF DESIGN. CONTRACTOR TO FIELD VERIFY LOCATION OF ALL EXISTING UNDERGROUND UTILITIES.
- THE CONTRACTOR SHALL BE RESPONSIBLE FOR ALL REPAIRS AND COSTS TO CORRECT DAMAGES RESULTING FROM FAILURE TO TAKE ALL NECESSARY PRECAUTIONS INCLUDING LOCATING, MARKING AND CAREFUL EXCAVATION. (CONTRACTOR SHALL AVOID DAMAGING EXISTING IRRIGATION SYSTEMS. IN CASE OF DAMAGE, THE CONTRACTOR SHALL REPLACE IRRIGATION SYSTEMS TO MATCH EXISTING CONDITIONS AND LOCATION).
- IT IS THE OBLIGATION OF THE CONTRACTOR TO MAKE HIS OWN INVESTIGATION AND SATISFY HIMSELF FULLY OF SUBSURFACE CONDITIONS.
- IF UPON EXCAVATION, AN EXISTING UTILITY IS FOUND TO BE IN CONFLICT WITH THE PROPOSED CONSTRUCTION OR TO BE OF A SIZE OR MATERIAL DIFFERENT FROM THAT SHOWN ON THE PLANS, THE CONTRACTOR SHALL IMMEDIATELY NOTIFY THE CITY OF DORAL PUBLIC WORKS DIRECTOR.
- CONTRACTOR SHALL PROVIDE HIS OWN LINE AND GRADE FROM HORIZONTAL AND VERTICAL CONTROL.
- FOR EACH PROJECT AREA, VERTICAL CONTROL IS BASED ON THE NATIONAL GEODETIC VERTICAL DATUM OF 1929.
- TOPOGRAPHICAL INFORMATION WAS PROVIDED BY F.R. ALEMAN & ASSOCIATES (FRA) AND WAS PERFORMED IN FEBRUARY AND MARCH 2015. FRA ALSO ESTABLISHED SURVEY CONTROL IDENTIFIED ON THE PLANS. NOT ALL TREES, FENCES, AND OTHER TOPOGRAPHIC FEATURES WERE SURVEYED AS PART OF THIS EFFORT. THE PRIMARY SURVEY SCOPE WAS TO OBTAIN CANAL CROSS SECTIONS AND LIMITED TOPOGRAPHIC DATA. CONTRACTOR SHALL PROVIDE HIS OWN TOPOGRAPHIC SURVEY SERVICE.
- ANY N.G.V.D. BENCH MARK MONUMENTS WITHIN THE LIMITS OF CONSTRUCTION IS TO BE PROTECTED AND PROPERLY REFERENCED BY A REGISTERED-LAND SURVEYOR IN ACCORDANCE WITH THE MINIMUM TECHNICAL STANDARDS OF THE FLORIDA BOARD OF PROFESSIONAL LAND SURVEYORS PRIOR TO BEGINNING WORK AT THE SITE.
- ALL STATIONS AND OFFSETS REFER TO [BASELINE] OF CONSTRUCTION, UNLESS OTHERWISE STATED.
- CONTRACTOR SHALL NOT SCALE DIMENSIONS FROM PLANS FOR CONSTRUCTION PURPOSES.
- THE CONTRACTOR IS ALERTED TO THE PRESENCE OF UNDERGROUND WIRES AND POLES IN THE PROJECT AREA. THE METHOD OF CONSTRUCTION IN THESE LOCATIONS MUST COMPLY WITH ALL OSHA SAFETY STANDARDS. THE CONTRACTOR SHALL INSPECT THESE SITES AND BE RESPONSIBLE FOR DETERMINING WHAT METHOD OF PREPARATION AND CONSTRUCTION WILL BE USED TO COMPLY WITH THESE REQUIREMENTS.
- ALL GEOTECHNICAL INFORMATION WAS OBTAINED FROM DUNKELBERGER ENGINEERING & TESTING, INC. DATED MARCH 2015. CONTRACTOR TO REFER TO PLANS FOR SUB-SURFACE PROFILE AND TO PROVIDE HIS OWN GEOTECHNICAL EXPLORATION SERVICES.
- THE CONTRACTOR SHALL NOTIFY THE CITY OF DORAL PUBLIC WORKS DEPARTMENT AT LEAST 24 HOURS PRIOR TO BEGINNING OF WORK.
- THE CANAL IMPROVEMENT WORK SHALL INCLUDE DIGGING, SHAPING, SLOPING, SLOPE STABILIZATION AND OTHER EARTHWORK BANK STABILIZATION NECESSARY TO BUILD BANK STABILIZATION TO THE REQUIRED GRADES, ALIGNMENTS AND CROSS SLOPE STABILIZATION SECTIONS DEPICTED ON THE PLANS.
- WHERE MATERIAL OR DEBRIS HAS WASHED OR FLOWED INTO OR BEEN PLACED IN WATER COURSES, GRAVITY SEWER, DITCHES, DRAINS, CATCH BASINS, OR ELSEWHERE AS A RESULT OF THE CONTRACTOR'S OPERATIONS, SUCH MATERIAL OR DEBRIS SHALL BE REMOVED AND SATISFACTORILY DISPOSED OF DURING PROGRESS OF THE WORK, AND THE AREA KEPT IN A CLEAN AND NEAT CONDITION.
- THE CONTRACTOR SHALL RESTORE OR REPLACE, WHEN AND AS DIRECTED BY THE CITY OF DORAL, ANY PUBLIC OR PRIVATE PROPERTY DAMAGED BY THE WORK, EQUIPMENT, EMPLOYEES OR SUBCONTRACTORS TO A CONDITION AT LEAST EQUAL TO THAT EXISTING IMMEDIATELY PRIOR TO THE BEGINNING OF OPERATIONS.
- CONTRACTOR SHALL MAINTAIN EXISTING TRAFFIC FLOW PATTERNS THROUGHOUT ALL WORK OPERATIONS. MAINTENANCE OF TRAFFIC IN THE PUBLIC RIGHT-OF-WAY SHALL BE IN ACCORDANCE WITH THE CITY OF DORAL, MUTCD, MIAMI-DADE PUBLIC WORKS DEPARTMENT AND FDOT.
- ALL EXCAVATIONS SHALL COMPLY WITH OSHA'S EXCAVATION SAFETY STANDARDS AND FLORIDA'S TRENCH SAFETY ACT. CONTRACTOR SHALL FURNISH THE OWNER WITH WRITTEN ASSURANCE THAT HE WILL COMPLY WITH THESE REGULATIONS.
- THE PROJECT SITE AND ALL ADJACENT AREAS SHALL BE MAINTAINED IN A NEAT AND CLEAN MANNER. UPON FINAL CLEAN UP, THE PROJECT SITE SHALL BE LEFT CLEAR OF ALL SURPLUS MATERIAL OR TRASH.
- CONTRACTOR IS TO VERIFY THE EXACT LOCATION OF ALL EXISTING TREES, STRUCTURES AND UTILITIES WHICH MAY NOT BE SHOWN ON PLANS. ANY STRUCTURE, PAVEMENT, TREES OR OTHER EXISTING IMPROVEMENT NOT SPECIFIED FOR REMOVAL WHICH IS TEMPORARILY DAMAGED, EXPOSED OR IN ANY WAY DISTURBED BY CONSTRUCTION PERFORMED UNDER THIS CONTRACT, SHALL BE REPAIRED, PATCHED OR REPLACED AT NO ADDITIONAL COST TO THE OWNER.
- CONTRACTOR TO RELOCATE TREES AS DIRECTED BY THE CITY OF DORAL. CONTRACTOR SHALL AVOID DAMAGE TO ANY EXISTING TREES TO REMAIN. EXISTING TREES SHALL BE REMOVED ONLY IF REQUIRED FOR CONSTRUCTION. THOSE TREES NOT INTERFERING WITH CONSTRUCTION SHALL BE PROTECTED IN PLACE.
- CONTRACTOR SHALL MAINTAIN THE SLOPES SHOWN ON THE CROSS-SECTION PLANS. BY NO MEANS THE CONTRACTOR SHALL ALTER THE CANAL'S TYPICAL CROSS-SECTIONS UNLESS OTHERWISE SHOWN ON THE PLANS.

**GENERAL NOTES (CONTINUED)**

- THE CONTRACTOR SHALL BE RESPONSIBLE FOR REPAIRING OR REPLACING AT HIS OWN EXPENSE ANY ITEMS DAMAGED DUE TO HIS PERSONNEL OR EQUIPMENT INSIDE AND/OR OUTSIDE OF THE CONSTRUCTION AREA.
- CONTRACTOR SHALL INSURE THAT ALL MUD OR ANY OTHER TYPE OF DEBRIS IS CLEANED FROM ADJACENT ROADWAYS (WHERE APPLICABLE) AT THE END OF EACH DAY. CONTRACTORS SHALL BE LIABLE FOR ANY PERSONAL OR PROPERTY DAMAGE CAUSED BY ANY TYPE OF DEBRIS LEFT ON ROADWAYS AND/OR PEDESTRIAN WAYS.
- CONTRACTOR SHALL AVOID DAMAGING EXISTING IRRIGATION SYSTEMS. IN CASE OF DAMAGE, THE CONTRACTOR SHALL REPLACE IRRIGATION SYSTEMS TO MATCH EXISTING CONDITIONS AND LOCATION.
- THE INFORMATION PROVIDED IN THESE DRAWINGS IS SOLELY TO ASSIST THE CONTRACTOR IN ASSESSING THE NATURE AND EXTENT OF CONDITIONS WHICH WILL BE ENCOUNTERED DURING THE COURSE OF WORK. THE CONTRACTORS ARE DIRECTED, PRIOR TO BIDDING, TO CONDUCT WHATEVER INVESTIGATIONS THEY DEEM NECESSARY TO ARRIVE AT THEIR OWN CONCLUSION REGARDING THE ACTUAL CONDITIONS THAT WILL BE ENCOUNTERED, AND UPON WHICH BIDS WILL BE BASED.
- CONTRACTOR TO COORDINATE STAGING AREA WITH PEPSI MANAGEMENT.

**SOIL EROSION, SEDIMENT, AND TURBIDITY CONTROL GENERAL NOTES**

- THIS PROJECT IS SUBJECT TO ALL RELATED ENVIRONMENTAL REQUIREMENTS WHICH INCLUDE A "CONTROL OF EROSION AND SEDIMENTATION PLAN". THE CONTRACTOR IS RESPONSIBLE FOR PROVIDING NECESSARY AND ADEQUATE MEASURES FOR PROPER CONTROL OF EROSION DUE TO SEDIMENTATION RUNOFF FROM THE SITE PRIOR TO CONSTRUCTION OPERATIONS IN A PARTICULAR AREA. ALL SEDIMENTATION AND EROSION CONTROL MEASURES SHALL BE IN PLACE PRIOR TO START OF CONSTRUCTION. FIELD ADJUSTMENTS WITH RESPECT TO LOCATIONS AND DIMENSIONS MAY BE MADE BY THE ENGINEER AS REQUIRED.
- EROSION CONTROL MEASURES WILL BE INSPECTED AT LEAST WEEKLY AND AFTER EACH RAIN FOR DAMAGE AND GENERAL EFFECTIVENESS. ANY DAMAGED OR INEFFECTIVE CONTROLS SHALL BE REPAIRED OR REPLACED BY THE CONTRACTOR.
- ADDITIONAL EROSION AND SEDIMENT CONTROL MEASURES WILL BE INSTALLED, IF DEEMED NECESSARY, BY THE ON-SITE INSPECTOR.
- EROSION CONTROL MEASURES WILL BE MAINTAINED AT ALL TIMES. TEMPORARY AND PERMANENT MAINTENANCE OF ALL EROSION AND SEDIMENT CONTROL MEASURES SHALL BE THE SOLE RESPONSIBILITY OF THE CONTRACTOR.
- ALL TEMPORARY SEDIMENT CONTROL DEVICES SHALL BE LEFT IN PLACE AND MAINTAINED UNTIL THE AREA HAS BEEN COMPLETELY STABILIZED WITH PERMANENT VEGETATION.
- ALL CONSTRUCTION EXITS SHALL BE MAINTAINED IN A CONDITION WHICH WILL PREVENT TRACKING OR FLOW OF MUD ON TO ANY PUBLIC RIGHT-OF-WAY. THIS SHALL REQUIRE PERIODIC TOP DRESSING WITH STONE, AS CONDITIONS REQUIRE. ALL MATERIALS SPILLED, DROPPED, WASHED OR TRACKED ON TO PUBLIC RIGHT-OF-WAY OR INTO STORM DRAINS SHALL BE PROMPTLY REMOVED BY CONTRACTOR.
- FLOATING TURBIDITY BARRIERS SHALL BE INSTALLED AND MAINTAINED AS CLOSE AS POSSIBLE TO THE CONSTRUCTION OPERATION UPSTREAM AND DOWNSTREAM OF CANALS. TURBIDITY BARRIERS SHALL BE INSTALLED IN ACCORDANCE WITH THE PLANS AND DETAILS.
- TURBIDITY SCREENS OR EQUIVALENT SHALL BE PROPERLY EMPLOYED AND MAINTAINED AS NECESSARY DURING CONSTRUCTION ACTIVITIES SO THAT TURBIDITY LEVELS DO NOT EXCEED 29 NTU's ABOVE NATURAL BACKGROUND 50 FEET DOWNSTREAM OF POINT OF DISCHARGE. IF TURBIDITY LEVELS EXCEED THESE LIMITS, PROJECT ACTIVITIES SHALL IMMEDIATELY CEASE, AND WORK SHALL NOT RESUME UNTIL TURBIDITY LEVELS DROP TO WITHIN THESE LIMITS.
- CONTRACTOR SHALL SOD GRASS AREAS DAMAGED DURING CONSTRUCTION AT NO ADDITIONAL COST TO OWNER.
- CONTRACTOR SHALL COMPLY WITH THE REQUIREMENTS OF THE ENVIRONMENTAL PROTECTION AGENCY (EPA) AND THE NATIONAL POLLUTION DISCHARGE ELIMINATION SYSTEM (NPDES).

**AS-BUILT REQUIREMENT NOTES**

- THE CONTRACTOR SHALL MAINTAIN ACCURATE AND COMPLETE RECORDS OF WORK ITEMS COMPLETED.
- ALL "AS-BUILT" INFORMATION SUBMITTED TO THE CITY PUBLIC WORKS DIRECTOR SHALL BE SUFFICIENTLY ACCURATE, CLEAR AND LEGIBLE TO SATISFY THE CITY OF DORAL THAT THE INFORMATION PROVIDES A TRUE REPRESENTATION OF THE COMPLETED WORK. AS-BUILT PLANS SHALL INCLUDE SURVEY CROSS SECTIONS AT BASELINE STATION INCLUDED IN THE CROSS SECTION PLANS.
- UPON COMPLETION OF CONSTRUCTION, THE CONTRACTOR SHALL SUBMIT TO THE CITY PUBLIC WORKS DIRECTOR ONE COMPLETE SET OF "AS-BUILT" CONSTRUCTION DRAWINGS. THESE DRAWINGS SHALL BE MARKED TO SHOW "AS-BUILT" CONSTRUCTION CHANGES AND DIMENSIONED LOCATIONS AND ELEVATIONS OF ALL WORK PERFORMED AND SHALL BE SIGNED BY THE CONTRACTOR.
- ALL "AS-BUILT" INFORMATION ON ELEVATIONS OF WORK PERFORMED SHALL BE CERTIFIED BY A REGISTERED LAND SURVEYOR.
- PRIOR TO A FINAL INSPECTION BY THE CITY OF DORAL, THE CONTRACTOR SHALL SUBMIT TO THE CITY TWO (2) SETS OF BLUEPRINTS OF "AS-BUILT" CONSTRUCTION DRAWINGS.
- UPON A FINAL INSPECTION BY THE CITY OF DORAL, THE CONTRACTOR SHALL SUBMIT TO THE CITY FIVE (5) SETS OF BLUE PRINTS OF "AS-BUILT" CONSTRUCTION DRAWINGS THAT HAVE BEEN CERTIFIED BY A REGISTERED LAND SURVEYOR, AND COMPUTER FILES OF "AS-BUILT" CONSTRUCTION DRAWINGS ON COMPACT DISK IN AUTOCAD RELEASE 2015 FORMAT OR LATEST EDITION AND PDF VERSION OF AS-BUILT.

**SEQUENCING NOTES**

- WORK ON SOUTHEAST CORNER OF NW 79th AVE AND PEPSI ACCESS ROAD TO BE PERFORMED ON WEEKENDS ONLY.
- WORK FROM STA 140+20 TO 149+00 TO BE PERFORMED FROM A BARGE AND NOT FROM PEPSI ACCESS ROAD.
- CONTRACTOR TO COORDINATE WITH PEPSI MANAGEMENT FOR LAND-SIDE WORK AREA FROM STA 149+00 TO 152+84.34.
- NORTH SIDE OF CANAL SHALL BE COMPLETED BEFORE SOUTH SIDE OF CANAL FROM STA 140+20 TO 152+84.34

**REVISIONS**

DATE	BY	DESCRIPTION	DATE	BY	DESCRIPTION



8550 N.W. 33RD STREET • SUITE 202  
DORAL, FLORIDA 33122  
PHONE (305) 551-4608 • FAX (305) 551-8977  
WWW.ADAENG.NET EB # 00003212

BY: \_\_\_\_\_  
**JEFFREY VOLLAT**  
P.E. No. 63930  
CIVIL ENG. STATE OF FL.



**CITY OF DORAL**  
**CANAL BANK RESTORATION**  
**PROGRAM - FISCAL YEAR 5**  
**(PHASE II)**

DATE: 06/2020	SCALE: N/A	CADD FILE: 02 GNRL-NOTES
DESIGN BY: J.V.	DRAWN BY: M.K.	CHECKED BY: C.O.

**GENERAL NOTES**

SHEET  
**2**  
OF 54

P:\Projects\173 City of Doral\0514\_Canal Bank Stabilization Program Management\01\_Year 5 Design\05\_Drawings\Year 5A - Phase II\03\_LEGEND-ABBR\_LR-5.dwg Jun 11, 2020 - 3:46pm CORTECA

**LEGEND:**

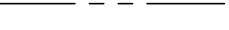
-  SET OR FOUND SURVEY CONTROL POINT
-  CENTERLINE
-  BASELINE
-  PALM
-  HARDWOOD TREE
-  EXOTIC TREE
- $\times 2.94$   EXISTING GROUND ELEVATION
-  POLE
-  LIGHTPOLE
-  SURVEY CONTROL POINT
-  SIGN (SINGLE SUPPORT)
-  DIAMETER
-  WIRING PULL BOX
-  CATCH BASIN
-  SIGNAL MAST ARM
-  EXISTING CHAIN LINK FENCE
-  PROPOSED CHAIN LINK FENCE
-  ELECTRIC LINE (OVERHEAD)
-  GUY ANCHOR
-  EXISTING GUARDRAIL
-  REPLACED GUARDRAIL
-  CANAL RIGHT OF WAY
-  CANAL MAINTENANCE EASEMENT

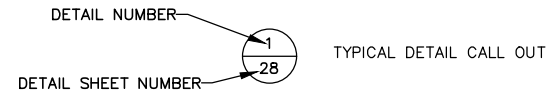

**ABBREVIATIONS:**

- ASPH. = ASPHALT
- BLCP = BASELINE CONTROL POINT (TO BE SET BY CONTRACTOR)
- BM = BENCHMARK
- BOC = BACK OF CURB
- CAP = CORRUGATED ALUMINUM PIPE
- CBS = CANAL BANK STABILIZATION
- C.L.F. = CHAIN LINK FENCE
- CLR = CLEAR
- CMP = CORRUGATED METAL PIPE
- CONC = CONCRETE
- COR = CORNER
- CSLAB = CONCRETE SLAB
- DIP = DUCTILE IRON PIPE
- EL. = ELEVATION
- ELEV. = ELEVATION
- EOP = EDGE OF PAVEMENT
- EOW = EDGE OF WATER
- EQUIV = EQUIVALENT
- ESMT = EASEMENT
- ETOB = EXISTING TOP OF BANK
- EXIST. = EXISTING
- FDOT = FLORIDA DEPARTMENT OF TRANSPORTATION
- FND = FOUND
- FT = FEET
- HOR. = HORIZONTAL
- INV = INVERT
- LB = POUND
- LT = OFFSET LEFT
- MEAS = MEASURED
- MIN = MINIMUM
- MUTCD = MANUAL OF UNIFORM TRAFFIC DEVICES
- N/A = NOT APPLICABLE
- NGVD = NATIONAL GEODETIC VERTICAL DATUM
- NPS = NOMINAL PIPE SIZE
- NTU = NEPHELOMETRIC TURBIDITY UNITS
- NTS = NOT TO SCALE
- NW = NORTHWEST
- PB = PLAT BOOK
- PED. = PEDESTRIAN
- PG = PAGE
- PI = POINT OF INTERSECTION
- PROP. = PROPOSED
- PSI = POUND PER SQUARE INCH
- PVC = POLYVINYL CHLORIDE
- PVMT. = PAVEMENT
- REC. = RECORD
- RGE. = RANGE
- RT = OFFSET RIGHT
- R/W = RIGHT OF WAY
- SCH = SCHEDULE
- SCP = SURVEY CONTROL POINT (EXISTING SURVEY MONUMENT)
- SEC = SECTION
- SDWK = SIDEWALK
- SFWM = SOUTH FLORIDA WATER MANAGEMENT DISTRICT
- STA. = STATION
- STD = STANDARD
- TOB = TOP OF BANK (PROPOSED)
- TWP. = TOWNSHIP
- VERT. = VERTICAL

**LEGEND STANDARD MANATEE CONDITIONS FOR IN-WATER WORK :**

THE PERMITTEE SHALL COMPLY WITH THE FOLLOWING CONDITION INTENDED TO PROTECT MANATEES FROM DIRECT PROJECT EFFECTS:

- A. ALL PERSONNEL ASSOCIATED WITH THE PROJECT SHALL BE INSTRUCTED ABOUT THE PRESENCE OF MANATEES AND MANATEE SPEED ZONES, AND THE NEED TO AVOID COLLISIONS WITH AND INJURY TO MANATEES. THE PERMITTEE SHALL ADVISE ALL CONSTRUCTION PERSONNEL THAT THERE ARE CIVIL AND CRIMINAL PENALTIES FOR HARMING, HARASSING, OR KILLING MANATEES WHICH ARE PROTECTED UNDER THE MARINE MAMMAL PROTECTION ACT, THE ENDANGERED SPECIES ACT, AND THE FLORIDA MANATEE SANCTUARY ACT.
- B. ALL VESSELS ASSOCIATED WITH CONSTRUCTION PROJECT SHALL OPERATE AT "IDLE SPEED/NO WAKE" AT ALL TIMES WHILE IN THE IMMEDIATE AREA AND WHILE IN WATER WHERE THE DRAFT OF THE VESSEL PROVIDES LESS THAN A FOUR-FOOT CLEARANCE FROM THE BOTTOM. ALL VESSELS WILL FOLLOW ROUTES OF DEEP WATER WHENEVER POSSIBLE.
- C. SILTATION OR TURBIDITY BARRIERS SHALL BE MADE OF MATERIAL IN WHICH MANATEES CANNOT BECOME ENTANGLED, SHALL BE PROPERLY SECURED, AND SHALL BE REGULARLY MONITORED TO AVOID MANATEE ENTANGLEMENT OR ENTRAPMENT. BARRIERS MUST NOT IMPEDE MANATEE MOVEMENT.
- D. ALL ON-SITE PROJECT PERSONNEL ARE RESPONSIBLE FOR OBSERVING WATER-RELATED ACTIVITIES FOR THE PRESENCE OF MANATEE(S). ALL IN-WATER OPERATIONS, INCLUDING VESSELS, MUST BE SHUTDOWN IF A MANATEE(S) COMES WITHIN 50 FEET OF THE OPERATION. ACTIVITIES WILL NOT RESUME UNTIL THE MANATEE(S) HAS MOVED BEYOND THE 50-FOOT RADIUS OF THE PROJECT OPERATION, OR UNTIL 30 MINUTES ELAPSES IF THE MANATEE(S) HAS NOT REAPPEARED WITHIN 50 FEET OF THE OPERATION. ANIMALS MUST NOT BE HERDED AWAY OR HARASSED INTO LEAVING.
- E. ANY COLLISION WITH OR INJURY TO A MANATEE SHALL BE REPORTED IMMEDIATELY TO THE FWC HOTLINE AT 1-888-404-3922. COLLISION AND/OR INJURY SHOULD ALSO BE REPORTED TO THE U.S. FISH AND WILDLIFE SERVICE IN JACKSONVILLE (1-904-731-3336) FOR NORTH FLORIDA OR VERO BEACH (1-772-562-3909) FOR SOUTH FLORIDA, AND TO FWC AT [IMPERILEDSPECIES@MYFWC.COM](mailto:IMPERILEDSPECIES@MYFWC.COM)
- F. TEMPORARY SIGNS CONCERNING MANATEES SHALL BE POSTED PRIOR TO AND DURING ALL IN-WATER PROJECT ACTIVITIES. ALL SIGNS ARE TO BE REMOVED BY THE PERMITTEE UPON COMPLETION OF THE PROJECT. TEMPORARY SIGNS THAT HAVE ALREADY BEEN APPROVED FOR THIS USE BY THE FLORIDA FISH AND WILDLIFE CONSERVATION COMMISSION (FWC) MUST BE USED (SEE MYFWC.COM/MANATEE). ONE SIGN WHICH READS CAUTION: BOATERS MUST BE POSTED. A SECOND SIGN MEASURING AT LEAST 8 1/2" BY 11" EXPLAINING THE REQUIREMENTS FOR "IDLE SPEED/NO WAKE" AND THE SHUT DOWN OF IN-WATER OPERATIONS MUST BE POSTED IN A LOCATION PROMINENTLY VISIBLE TO ALL PERSONNEL ENGAGED IN WATER-RELATED ACTIVITIES. QUESTIONS CONCERNING THESE SIGNS CAN BE SENT TO THE EMAIL ADDRESS LISTED ABOVE.

**REVISIONS**

DATE	BY	DESCRIPTION	DATE	BY	DESCRIPTION



8550 N.W. 33RD STREET • SUITE 202  
DORAL, FLORIDA 33122  
PHONE (305) 551-4608 • FAX (305) 551-8977  
WWW.ADAENG.NET EB # 00003212

BY: **JEFFREY VOLLAT**  
P.E. No. 63930  
CIVIL ENG. STATE OF FL.



**CITY OF DORAL**  
**CANAL BANK RESTORATION**  
**PROGRAM - FISCAL YEAR 5**  
**(PHASE II)**

DATE: 06/2020	SCALE: N/A	CADD FILE: 03 LEG & ABBR
DESIGN BY: J.V.	DRAWN BY: M.K.	CHECKED BY: C.O.

**LEGEND AND ABBREVIATIONS**

P:\Projects\173 City of Doral\0514\_Canal Bank Stabilization Program Management\01\_Year 5 Design\05\_Drawings\Year 5A - Phase II\04\_SUM-QUANTITY\_YR-5\_FINAL.dwg Jun 11, 2020 - 3:43pm CORTECA

**FISCAL YEAR 5A: DRESSELS CANAL EAST  
(SOUTH OF NW 41ST STREET, FROM 79TH AVE TO SR 826)**

ITEM NUMBER	BID ITEM	DESCRIPTION	UNITS	QUANTITY
1	P-01560-1	MOBILIZATION	LS	1
2	P-01570-1	MAINTENANCE OF TRAFFIC	LS	1
3	P-02050-3	15" METAL PIPE REMOVAL	LF	15
4	P-02050-4	18" HDPE PIPE INSTALLATION	LF	15
5	P-02110-1	CLEARING AND LAND PREPARATION	SY	2,132
6	P-02110-4	EMBANKMENT FILL	CY	445
7	P-02440-1	STACKED GEOWEB EXCAVATION	LF	2,220
8	P-02440-2	STACKED CBS INSTALLATION (BELOW EL. 2.0 FT-NGVD) <sup>1</sup>	LF	2,220
9	P-02240-3	STACKED CBS INSTALLATION (EL. 2.0 - 4.5 FT-NGVD) <sup>1</sup>	LF	2,220
10	P-02240-4	STACKED CBS INSTALLATION (ABOVE EL. 4.5 FT-NGVD) <sup>1</sup>	LF	2,220
11	P-02240-24	STACKED CBS WRAP-AROUND CULVERT (NW 79 AVE)	EA	1
12	P-02240-25	STACKED CBS WRAP-AROUND EXISTING HEADWALL	EA	1
13	P-02435-1	STAKED TURBIDITY BARRIER	LF	4,400
14	P-02435-2	FLOATING TURBIDITY BARRIER	LF	140
15	P-02444-1	GUARDRAIL INSTALLATION	LF	60
16	P-02480-1	FINISH GRADING AND SODDING	SY	2,132
17	P-02481-1	TREE REMOVAL	EA	28
18	P-02481-2	TRUNK REMOVAL	EA	1
19	P-02525-3	BEDDING STONE	CY	740
20	P-02831-1	REMOVAL OF EXISTING CHAIN LINK FENCE	LF	64

**NOTE:**

1. CONTRACTOR ACCESS TO EACH OF THE CANAL SEGMENT PAY ITEMS SHALL BE INCLUDED IN UNIT COSTS. ALSO, THIS COST INCLUDES TIE-INS TO EXISTING CONCRETE OR SAND CEMENT HEADWALLS.
2. GUARDRAIL INSTALLATION PAY ITEM NO. 18 SHALL INCLUDE THE COST OF REMOVAL AND DISPOSAL OF EXISTING GUARDRAIL.
3. PAY ITEM NO. 19 SHALL INCLUDE BEDDING STONE AS SHOWN ON PLAN SHEETS 19 AND 20, AND FOR BACKFILL AS SHOWN ON PLAN SHEET 21.
4. PAY ITEM NO. 12 SHALL INCLUDE REMOVAL AND DISPOSAL OF EXISTING HEADWALL AS SHOWN ON PLAN SHEET 21.

**REVISIONS**

DATE	BY	DESCRIPTION	DATE	BY	DESCRIPTION



8550 N.W. 33RD STREET • SUITE 202  
DORAL, FLORIDA 33122  
PHONE (305) 551-4608 • FAX (305) 551-8977  
WWW.ADAENG.NET EB # 00003212

BY: \_\_\_\_\_  
**JEFFREY VOLLAT**  
P.E. No. 63930  
CIVIL ENG. STATE OF FL.



**CITY OF DORAL  
CANAL BANK RESTORATION  
PROGRAM - FISCAL YEAR 5  
(PHASE II)**

DATE: 06/2020	SCALE: N/A	CADD FILE: 04 SUMY-QUAN
DESIGN BY: J.V.	DRAWN BY: M.K.	CHECKED BY: C.O.

**SUMMARY OF QUANTITIES**



P:\Projects\173 City of Doral\0514\_Canal Bank Stabilization Program Management\01\_Year 5 Design\05\_Drawings\Year 5A - Phase II\05\_KEY-SHEET\_YR-5.dwg Jun 11, 2020 - 3:50pm CORTEGA



**REVISIONS**

DATE	BY	DESCRIPTION	DATE	BY	DESCRIPTION
8/6/10	A.V.	△ CBS LIMITS			

 8550 N.W. 33RD STREET • SUITE 202  
 DORAL, FLORIDA 33122  
 PHONE (305) 551-4608 • FAX (305) 551-8977  
 WWW.ADAENG.NET EB # 00003212

BY:  
**JEFFREY VOLLAT**  
 P.E. No. 63930  
 CIVIL ENG. STATE OF FL.



**CITY OF DORAL**  
**CANAL BANK RESTORATION**  
**PROGRAM - FISCAL YEAR 5**  
**(PHASE II)**

DATE: 06/2020	SCALE: AS SHOWN	CADD FILE: 05 KEY SHEET
DESIGN BY: J.V.	DRAWN BY: M.K.	CHECKED BY: C.O.

**KEY SHEET**

SHEET  
**5**  
 OF 54

P:\Projects\173 City of Doral\0514\_Canal Bank Stabilization Program Management\01\_Year 5 Design\05\_Drawings\Year 5A - Phase II\06-07\_SURV-ONTL-YR-5.dwg Jun 11, 2020 - 3:47pm CORTEGA

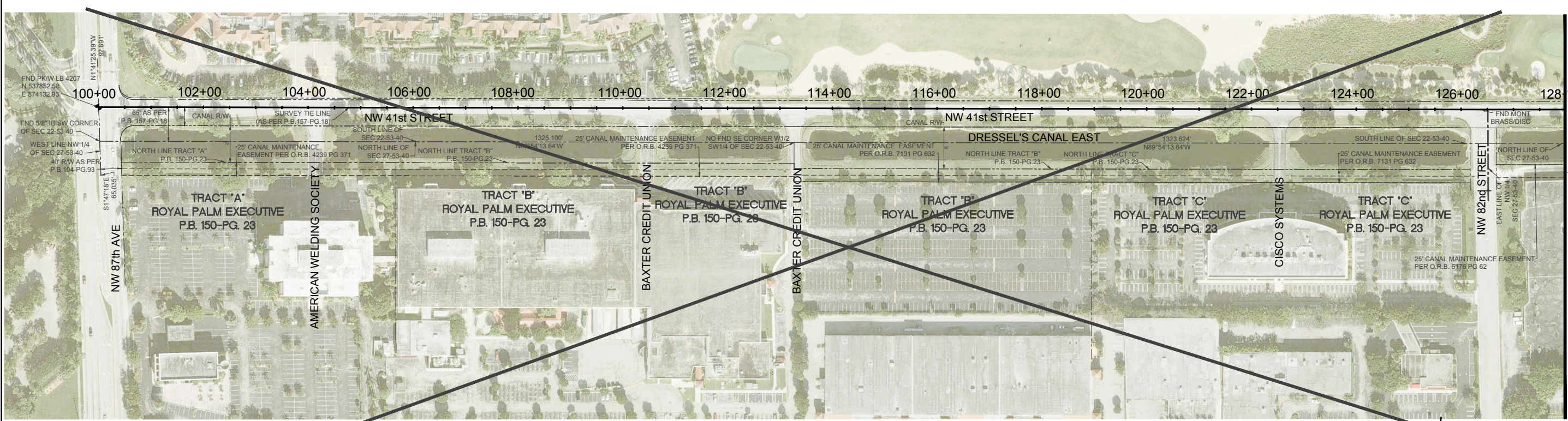

**STA. 100+00 TO 128+00**

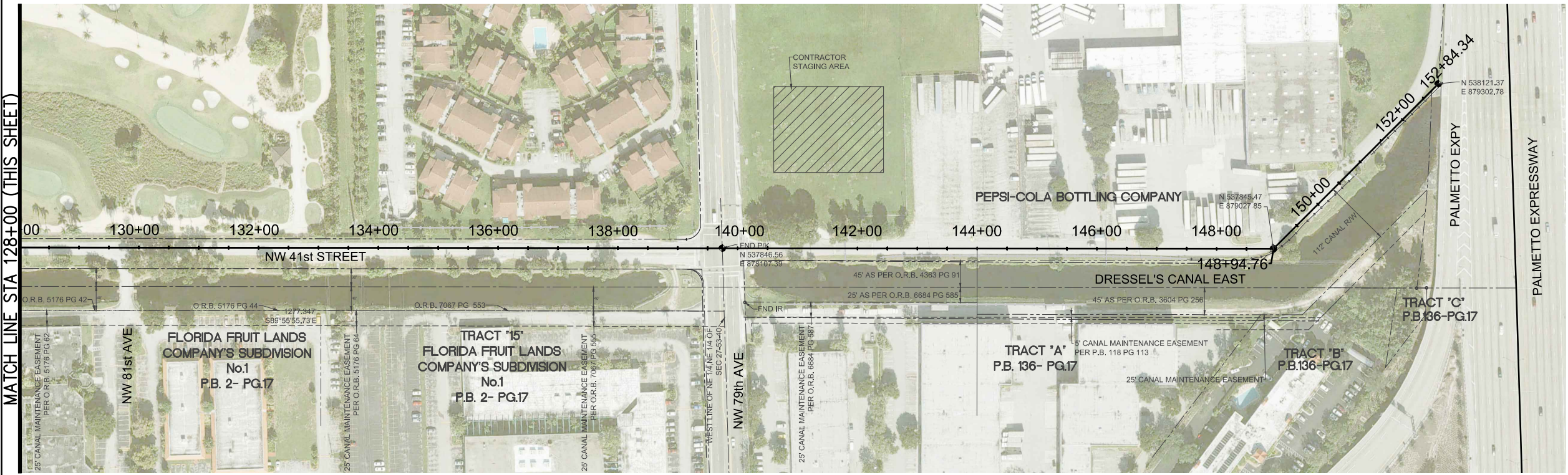

**STA. 128+00 TO 152+84.34**

- SURVEYOR'S NOTES:**
1. THIS IS NOT A BOUNDARY SURVEY.
  2. HORIZONTAL DATUM IS THE STATE PLANE COORDINATE SYSTEM, FLORIDA EAST ZONE, NORTH AMERICAN DATUM OF 1983 (ADJUSTMENT OF 1990).  
GPS SOTO N=558414.457 E=873247.407  
GPS THOMAS AZ N=548213.9702 E=861136.4316
  3. ELEVATIONS SHOWN REFER TO NATIONAL GEODETIC VERTICAL DATUM OF 1929 (NGVD 1929) AS DETERMINED MIAMI-DADE COUNTY- PUBLIC WORKS DEPARTMENT BM# 32 LOCATOR 3904S, BEING A FL DOT SURVEY 1' WEST OF WITNESS POST ON THE WEST SIDE OF WIRE FENCE LOCATED 590' NORTH OF C/L OF NW 34 STREET AND 28' WEST OF C/L OF NW 117 AVE. EL.=6.12 FEET (NGVD 1929) AND BM# TC-33 LOCATOR 3905S BEING A BRASS BAR IN CONC MON NORTH OF CULVERT CROSSING CONNECTING WEST AND EAST ROAD PARALLELING THE CANAL LOCATED 145' S OF C/L, 101' S OF MOST SOUTHERLY GUARD RAIL OF S R/W OF NW 25 STREET AND 17' WEST OF PAVING OF ABANDONED ROAD ON E SIDE OF 103' N OF N FACE OF A CONC CULVERT HEADWALL, 3' WEST OF GUARD RAIL OF NW 117 AVE. EL.=8.86' FEET (NGVD 1929).
  4. ELEVATIONS SHOWN ARE TO THE BOTTOM OF CANAL AS MEASURED WITH ROD OR CANNON BALL.
  5. WATER ELEVATION SHOWN ON PLANS ARE BASED ON WATER LEVELS OBSERVED IN MARCH 2015.

**REVISIONS**

DATE	BY	DESCRIPTION	DATE	BY	DESCRIPTION

**ADA**  
8550 N.W. 33RD STREET • SUITE 202  
DORAL, FLORIDA 33122  
PHONE (305) 551-4608 • FAX (305) 551-8977  
WWW.ADAENG.NET EB # 00003212

BY:  
**JEFFREY VOLLAT**  
P.E. No. 63930  
CIVIL ENG. STATE OF FL.



**CITY OF DORAL**  
**CANAL BANK RESTORATION**  
**PROGRAM - FISCAL YEAR 5**  
**(PHASE II)**

DATE: 06/2020	SCALE: AS SHOWN	CADD FILE: 10-22 PLAN
DESIGN BY: J.V.	DRAWN BY: M.K.	CHECKED BY: C.O.

**DRESSELS CANAL EAST**  
**SURVEY CONTROL PLAN**

P:\Projects\173 City of Doral\0514\_Canal Bank Stabilization Program Management\01\_Year 5 Design\05\_Drawings\Year 5A - Phase II\08-10 TYP SECT\_YR-5.dwg Jun 11, 2020 - 3:02pm CORTEGA

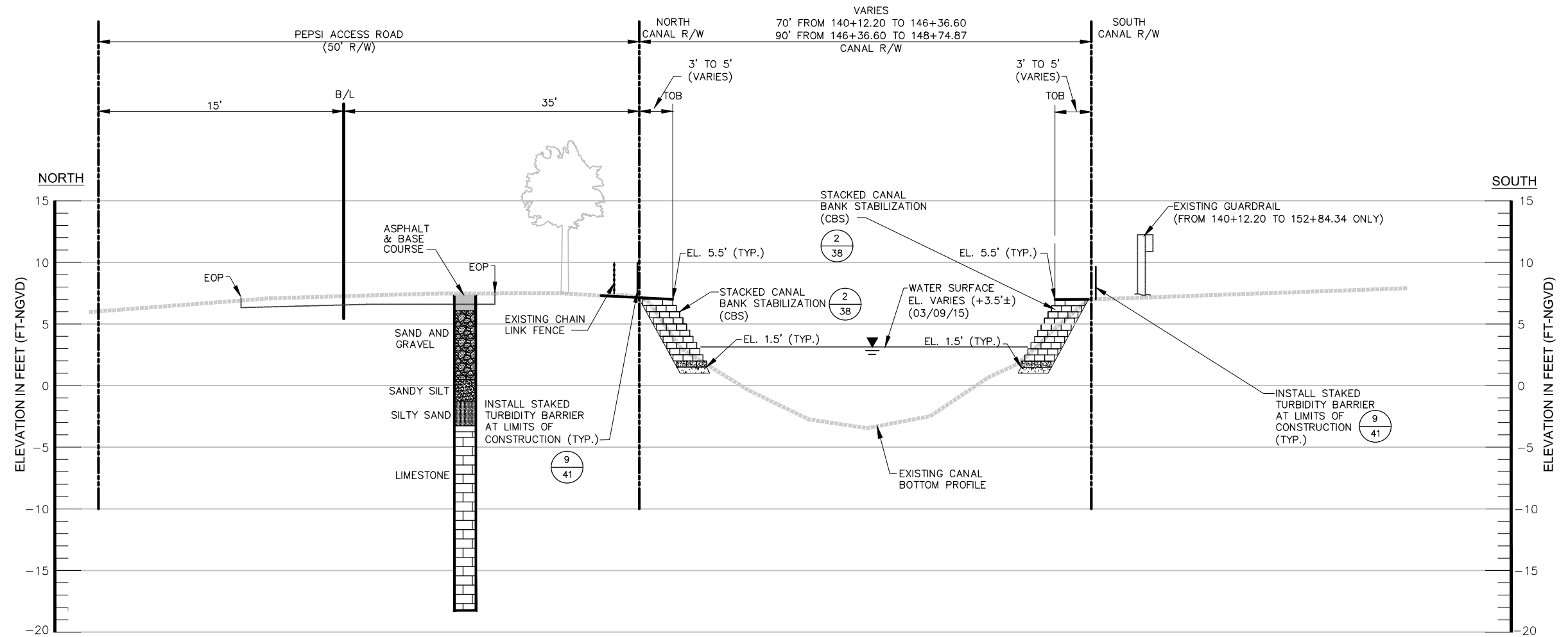

**DRESSELS CANAL EAST SECTION (STA 140+12.20 TO 152+84.34) TYPICAL**

SCALE: 1" = 10' HORIZONTAL  
1" = 10' VERTICAL

**REVISIONS**

DATE	BY	DESCRIPTION	DATE	BY	DESCRIPTION

**ADA**  
8550 N.W. 33RD STREET • SUITE 202  
DORAL, FLORIDA 33122  
PHONE (305) 551-4608 • FAX (305) 551-8977  
WWW.ADAENG.NET EB # 00003212

BY: **JEFFREY VOLLAT**  
P.E. No. 63930  
CIVIL ENG. STATE OF FL.



**CITY OF DORAL**  
**CANAL BANK RESTORATION**  
**PROGRAM - FISCAL YEAR 5**  
**(PHASE II)**

DATE: 07/12/19	SCALE: AS SHOWN	CADD FILE: 07-09 TYP SECTIONS
DESIGN BY: J.V.	DRAWN BY: M.K.	CHECKED BY: A.V.

**DRESSELS CANAL EAST**  
**STA 125+26.00 TO STA 152+84.34**  
**TYPICAL SECTIONS**

SHEET  
**10**  
OF 54

P:\Projects\0175 City of Doral\0514\_Canal Bank Stabilization Program Management\01\_Year 5 Design\05\_Drawings\Year 5A - Phase II\11-21\_P\ANS\_YR-5.dwg Jun 11, 2020 - 3:25pm GARCINEGA

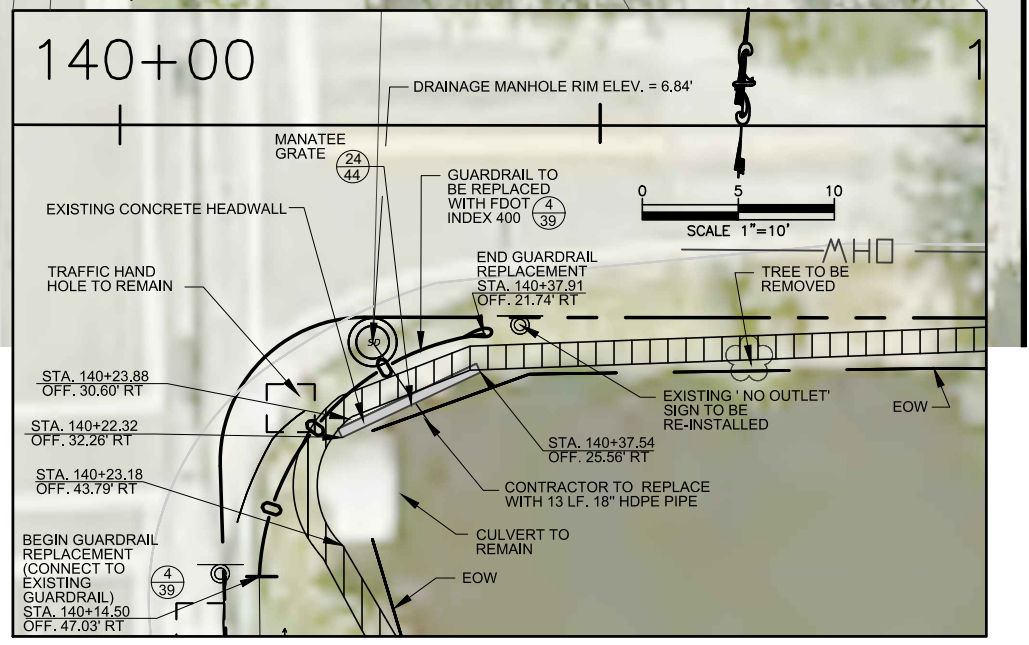
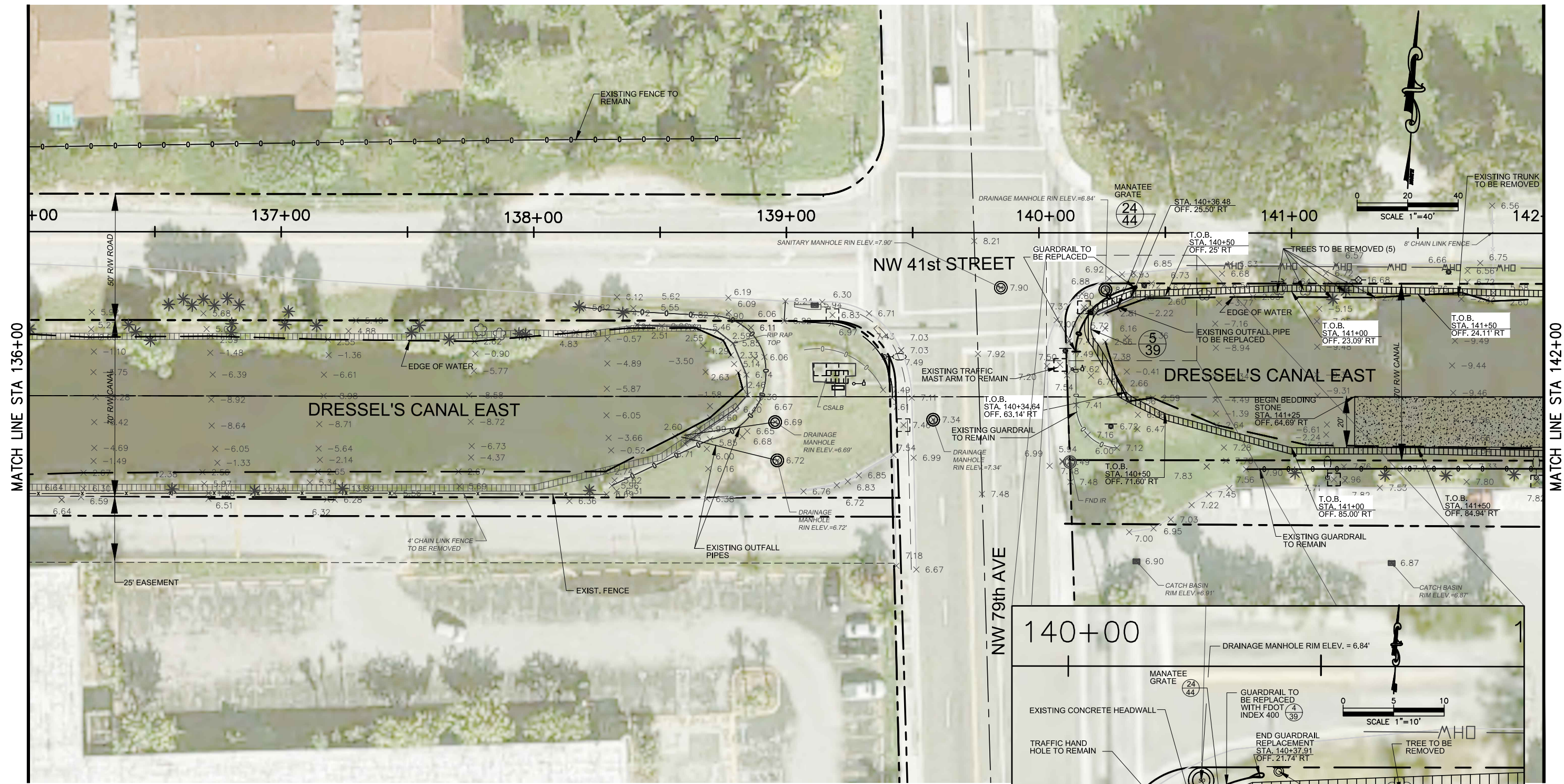

**REVISIONS**

DATE	BY	DESCRIPTION	DATE	BY	DESCRIPTION
8/6/10	A.V.	△ CBS LIMITS			

8550 N.W. 33RD STREET • SUITE 202  
 DORAL, FLORIDA 33122  
 PHONE (305) 551-4608 • FAX (305) 551-8977  
 WWW.ADAENG.NET EB # 00003212

BY: **JEFFREY VOLLAT**  
 P.E. No. 63930  
 CIVIL ENG. STATE OF FL.



**CITY OF DORAL**  
**CANAL BANK RESTORATION**  
**PROGRAM - FISCAL YEAR 5**  
**(PHASE II)**

DATE: 06/2020  
 SCALE: AS SHOWN  
 CADD FILE: 10-22 PLAN  
 DESIGN BY: J.V.  
 DRAWN BY: M.K.  
 CHECKED BY: C.O.

**DRESSELS CANAL - EAST**  
**STA 136+00 TO STA 142+00**  
**PLAN**

SHEET  
**19**  
 OF 54

PEPSI MANUFACTURING

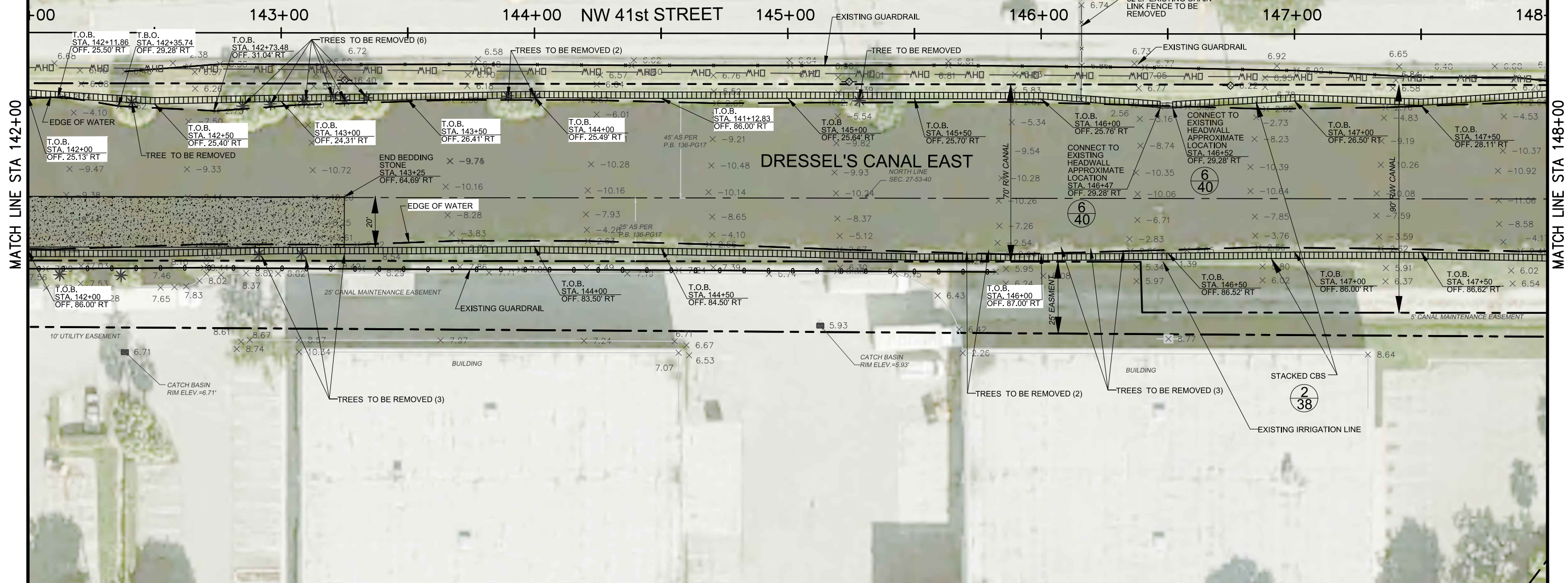
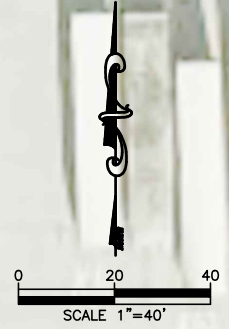

P:\Projects\0173 City of Doral\0514\_Canal Bank Stabilization Program Management\01\_Year 5 Design\05\_Drawings\Year 5A - Phase II\11-21\_PLANS\_YR-5.dwg Jun 11, 2020 - 3:25pm GARCINEGA

REVISIONS					
DATE	BY	DESCRIPTION	DATE	BY	DESCRIPTION
8/6/10	A.V.	PAVEMENT MARKING MODIFICATIONS	8/6/10	A.V.	NOTE MODIFICATION
8/6/10	A.V.	TRAFFIC LOOP RELOCATION			

 8550 N.W. 33RD STREET • SUITE 202  
 DORAL, FLORIDA 33122  
 PHONE (305) 551-4608 • FAX (305) 551-8977  
 WWW.ADAENG.NET EB # 00003212

BY: **JEFFREY VOLLAT**  
 P.E. No. 63930  
 CIVIL ENG. STATE OF FL.



**CITY OF DORAL**  
**CANAL BANK RESTORATION**  
**PROGRAM - FISCAL YEAR 5**  
**(PHASE II)**

DATE: 06/2020  
 SCALE: AS SHOWN  
 CADD FILE: 10-22 PLAN  
 DESIGN BY: J.V.  
 DRAWN BY: M.K.  
 CHECKED BY: C.O.

**DRESSELS CANAL-EAST**  
**STA 142+00 TO STA 148+00**  
**PLAN**

SHEET  
**20**  
 OF 54

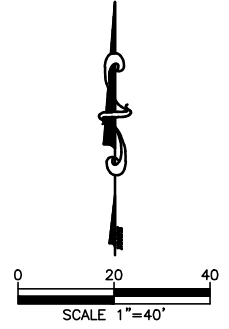
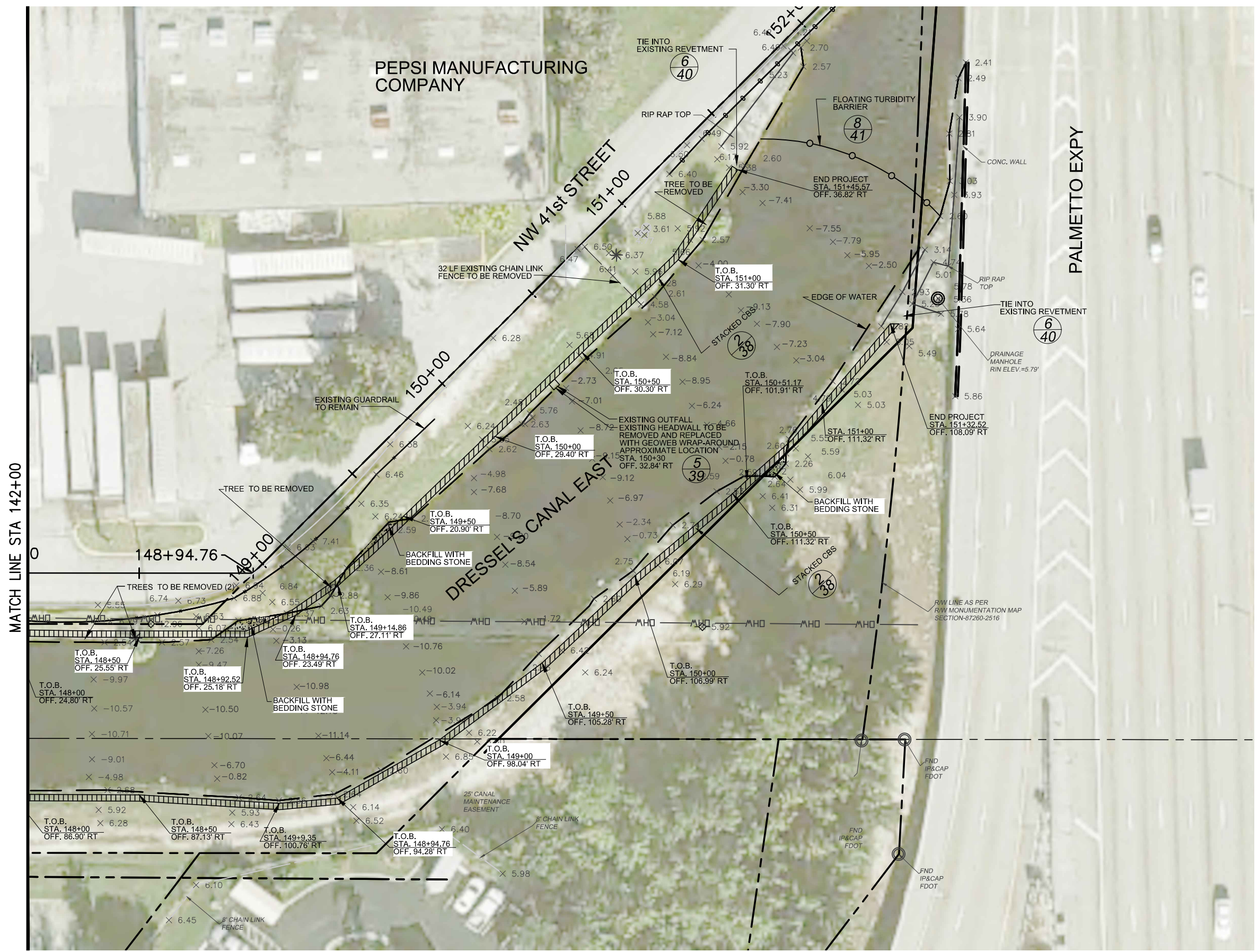
P:\Projects\173 City of Doral\0514\_Canal Bank Stabilization Program Management\01\_Year 5 Design\05\_Drawings\Year 5A - Phase II\11-21\_PUANS\_YR-5.dwg Jun 11, 2020 - 3:45pm CORTEGA



**REVISIONS**

DATE	BY	DESCRIPTION	DATE	BY	DESCRIPTION
8/6/10	A.V.	PAVEMENT MARKING MODIFICATIONS	8/6/10	A.V.	NOTE MODIFICATION
8/6/10	A.V.	TRAFFIC LOOP RELOCATION			



8550 N.W. 33RD STREET • SUITE 202  
DORAL, FLORIDA 33122  
PHONE (305) 551-4608 • FAX (305) 551-8977  
WWW.ADAENG.NET EB # 00003212

BY:  
**JEFFREY VOLLAT**  
P.E. No. 63930  
CIVIL ENG. STATE OF FL.



**CITY OF DORAL  
CANAL BANK RESTORATION  
PROGRAM - FISCAL YEAR 5  
(PHASE II)**

DATE: 06/2020	SCALE: AS SHOWN	CADD FILE: 10-22 PLAN
DESIGN BY: J.V.	DRAWN BY: M.K.	CHECKED BY: C.O.

**DRESSELS CANAL-EAST  
STA 148+00 TO STA 152+84.34  
PLAN**

P:\Projects\173 City of Doral\0514\_Canal Bank Stabilization Program Management\01\_Year 5 Design\05\_Drawings\Year 5A - Phase II\22-37\_CROSS-SECT\_IR-5.dwg Jun 11, 2020 - 3:17pm CORTEGA

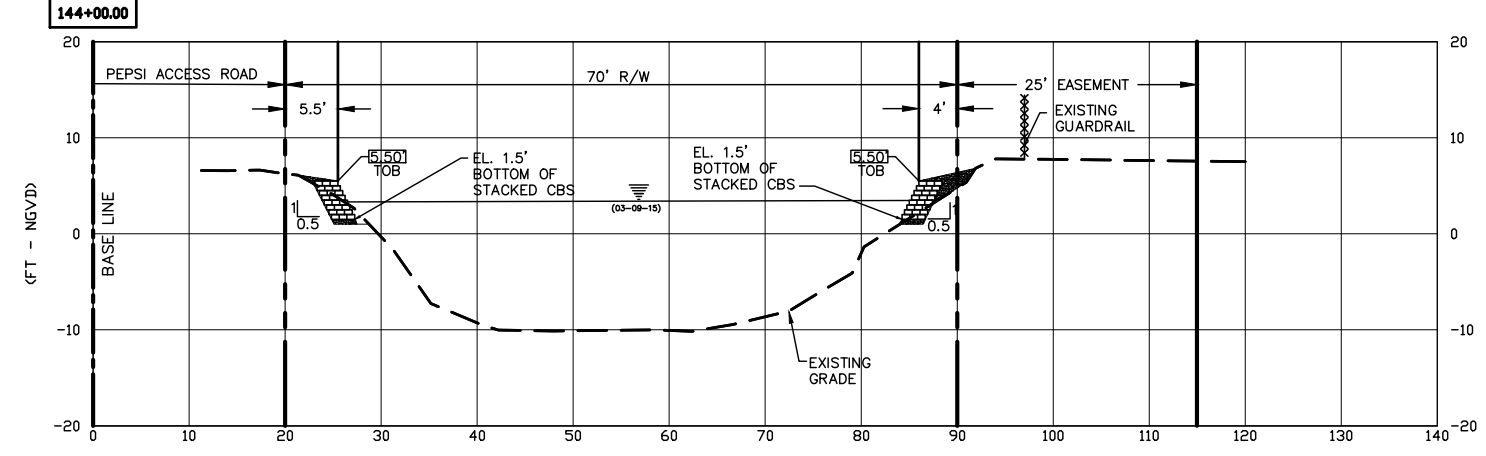
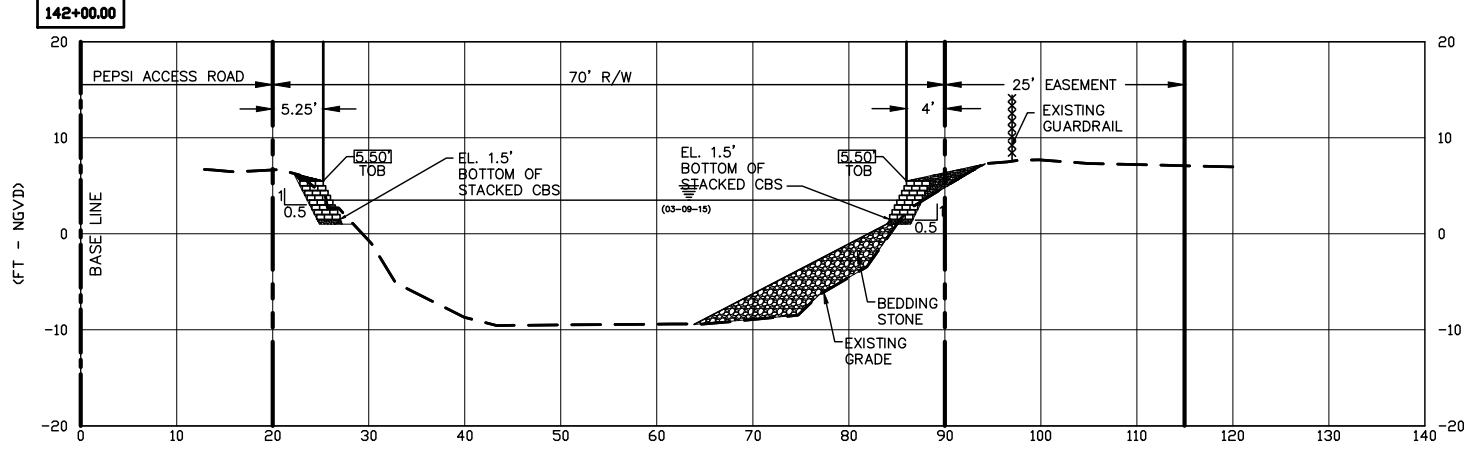
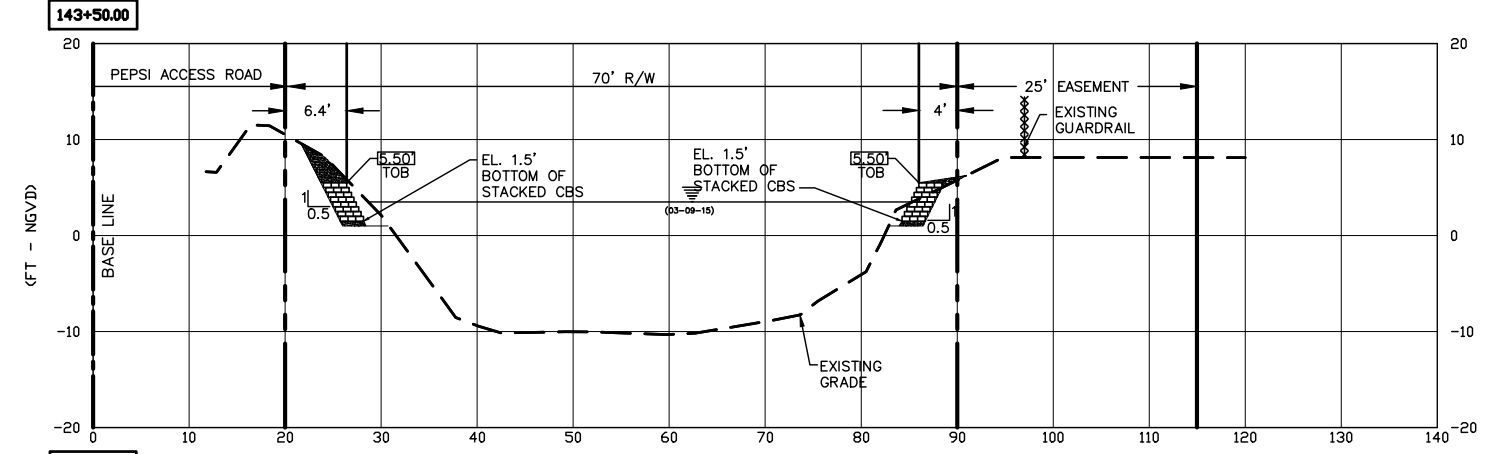
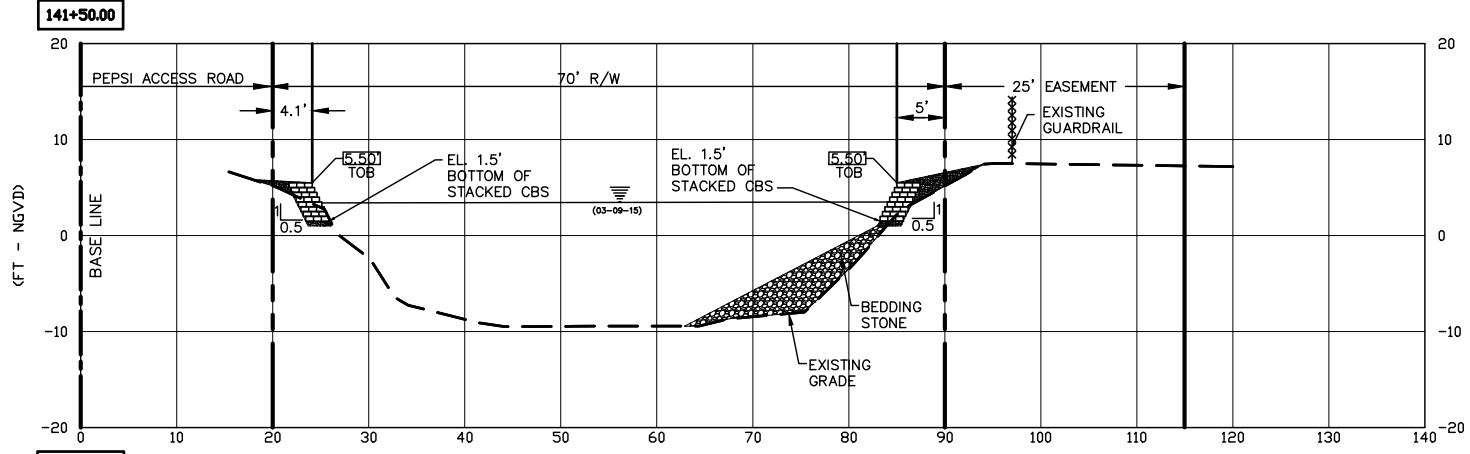
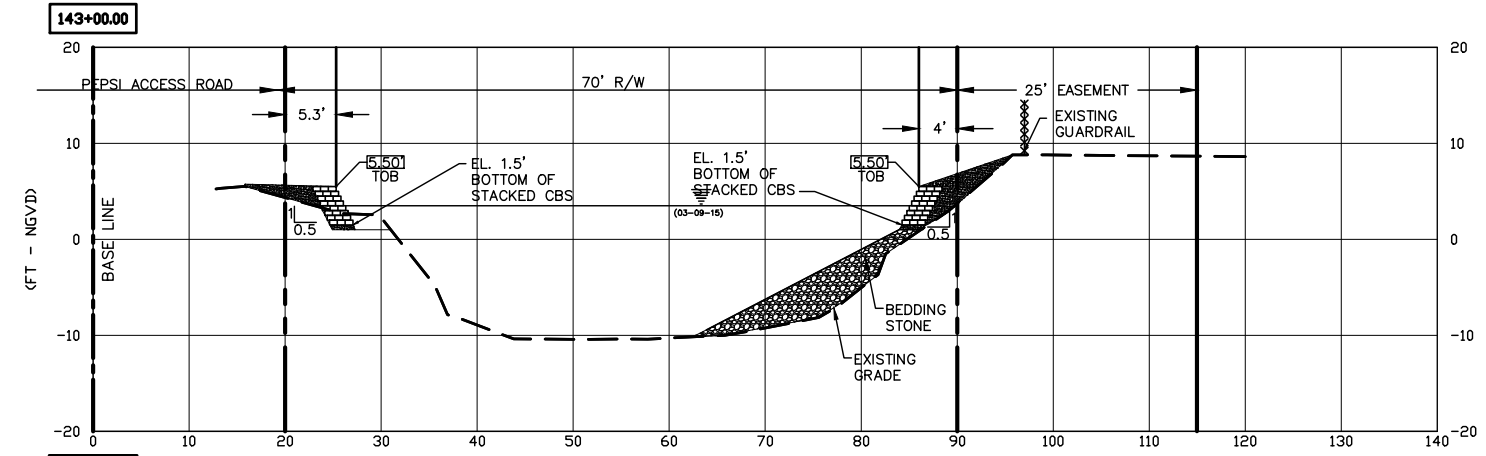
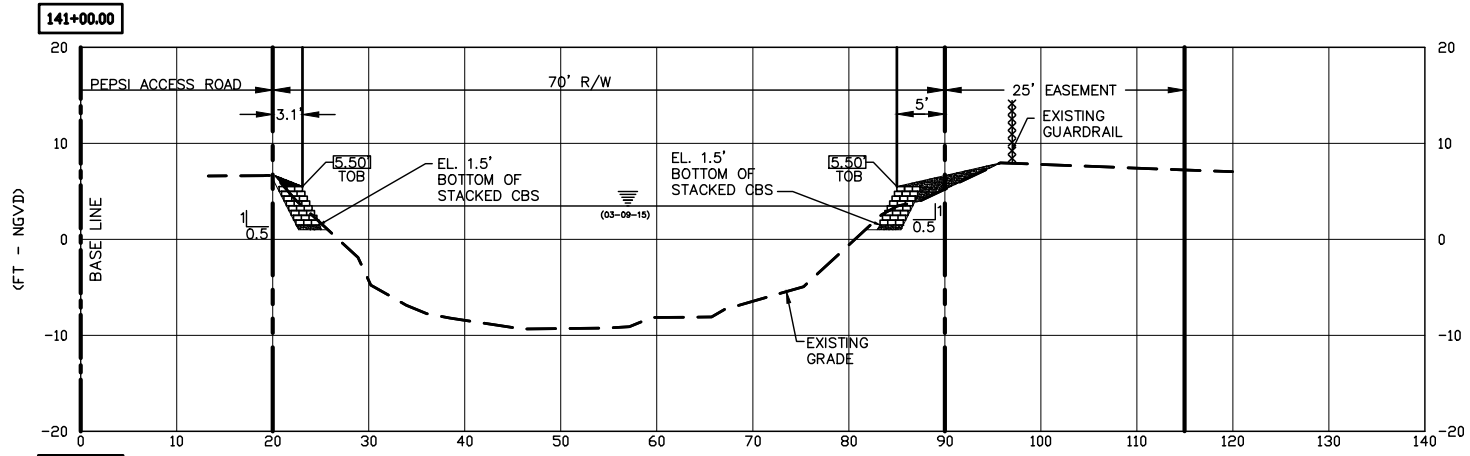
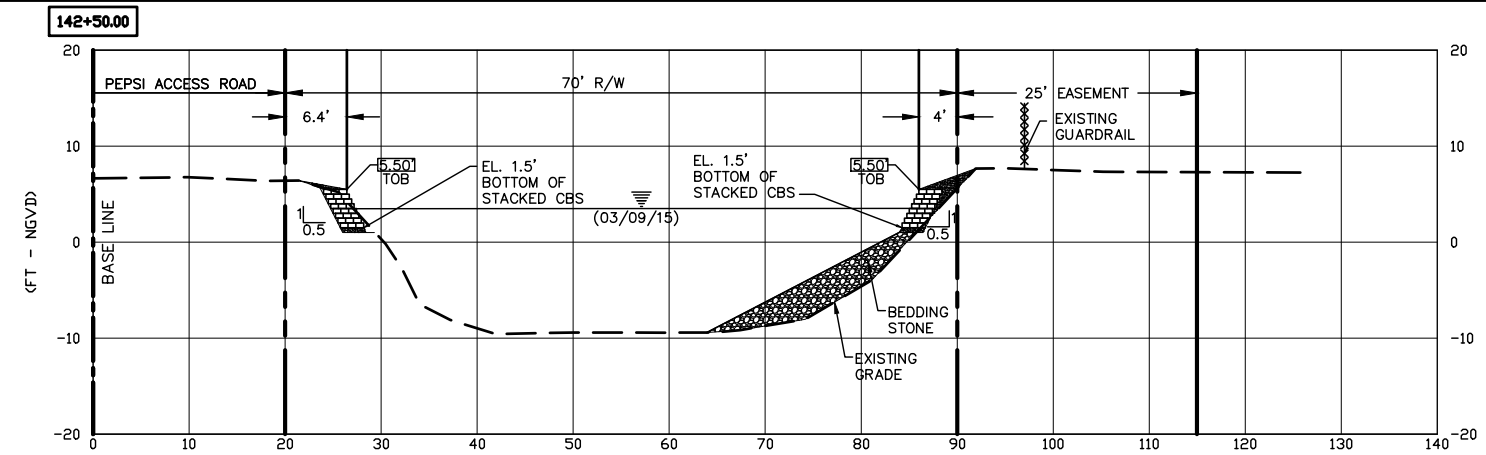
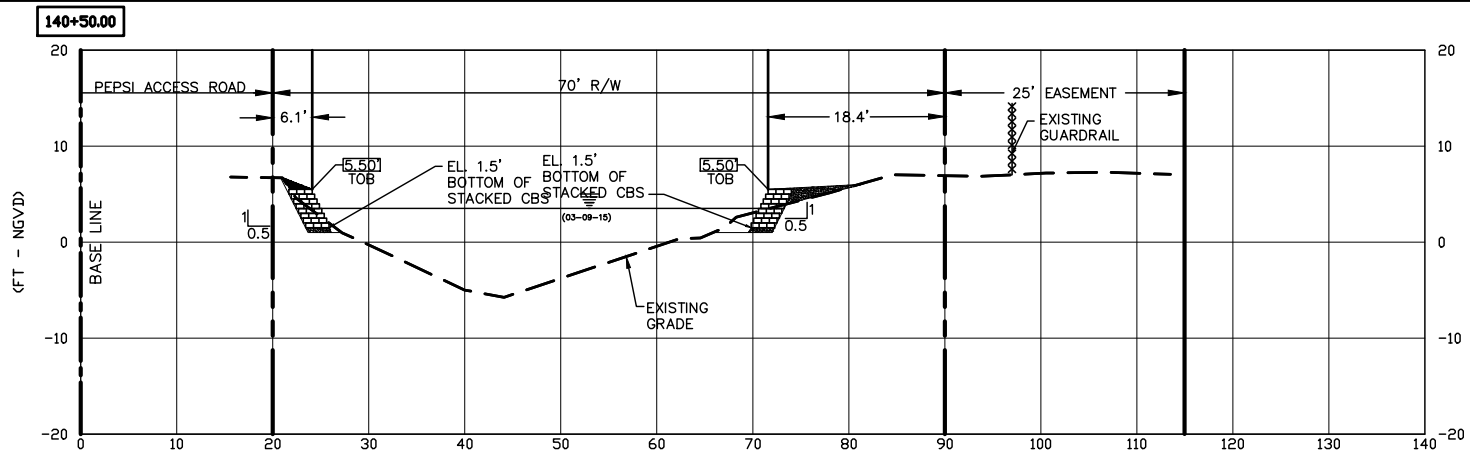

SCALE: 1" = 20' HORIZONTAL  
1" = 20' VERTICAL

**REVISIONS**

DATE	BY	DESCRIPTION	DATE	BY	DESCRIPTION

**ADA**  
8550 N.W. 33RD STREET • SUITE 202  
DORAL, FLORIDA 33122  
PHONE (305) 551-4608 • FAX (305) 551-8977  
WWW.ADAENG.NET EB # 00003212

BY:  
**JEFFREY VOLLAT**  
P.E. No. 63930  
CIVIL ENG. STATE OF FL.



**CITY OF DORAL**  
**CANAL BANK RESTORATION**  
**PROGRAM - FISCAL YEAR 5**  
**(PHASE II)**

DATE: 06/2020  
SCALE: AS SHOWN  
CADD FILE: 22-37\_CROSS  
DESIGN BY: J.V.  
DRAWN BY: M.K.  
CHECKED BY: C.O.

**DRESSELS CANAL - EAST**  
**STA. 140+50 TO 144+00**  
**CANAL CROSS SECTIONS**

P:\Projects\173 City of Doral\0514\_Canal Bank Stabilization Program Management\01\_Year 5 Design\05\_Drawings\Year 5A - Phase II\22-37 CBOS-SECT\_IR-5.dwg Jun 11, 2020 - 3:18pm CORTEGA

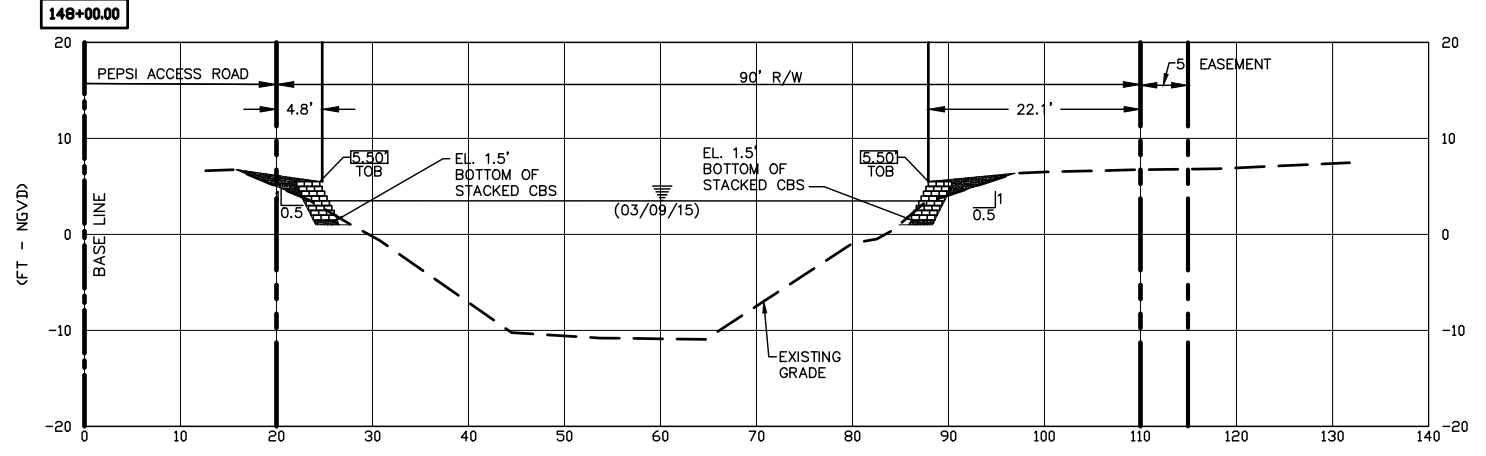
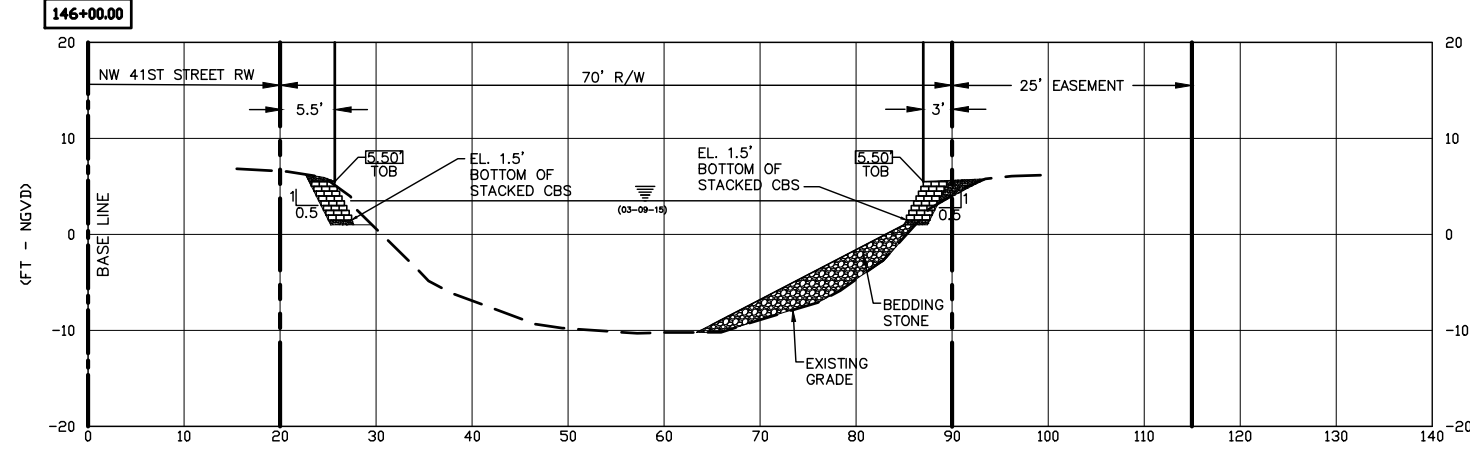
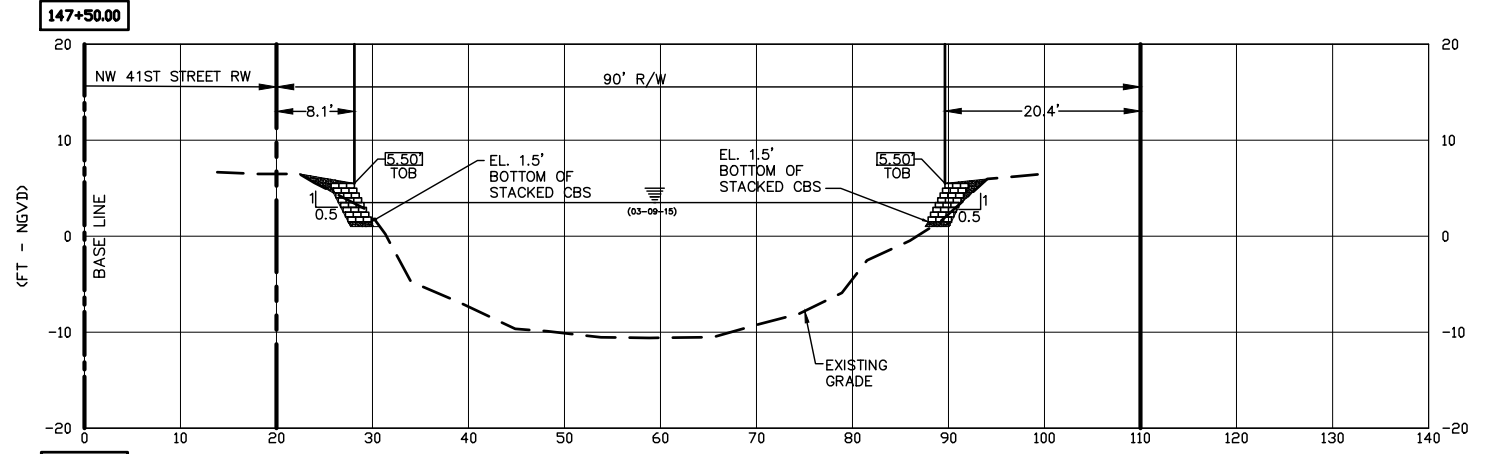
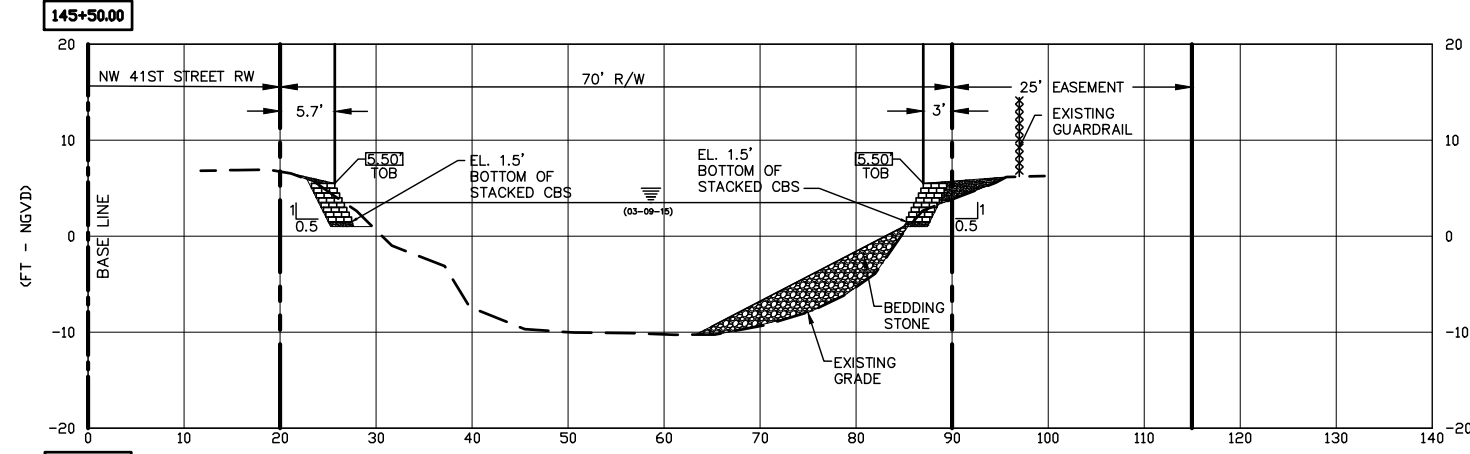
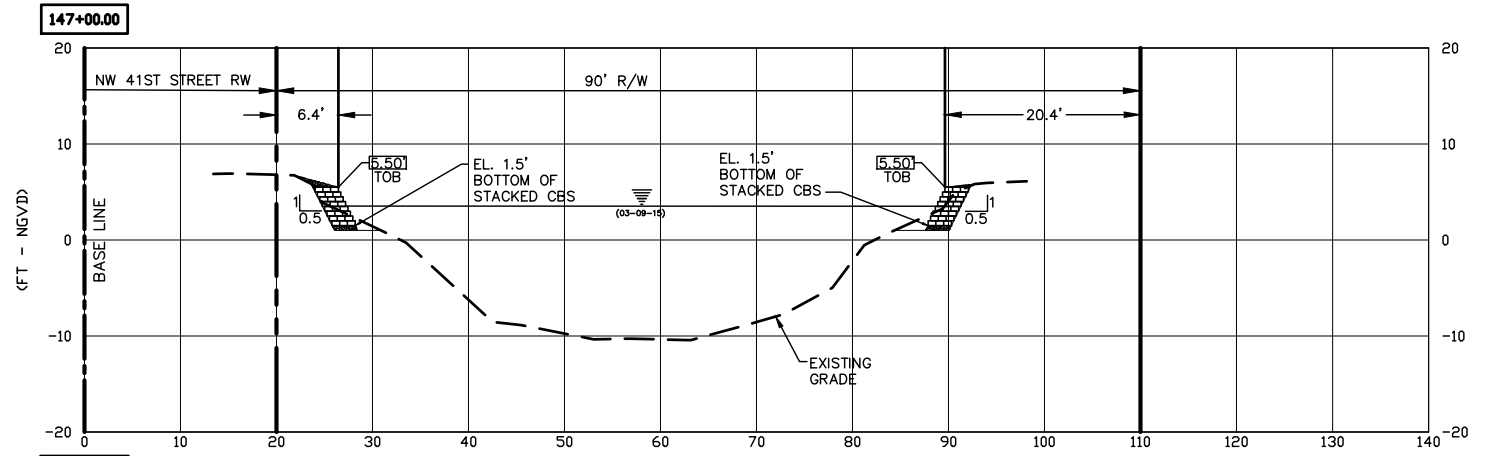
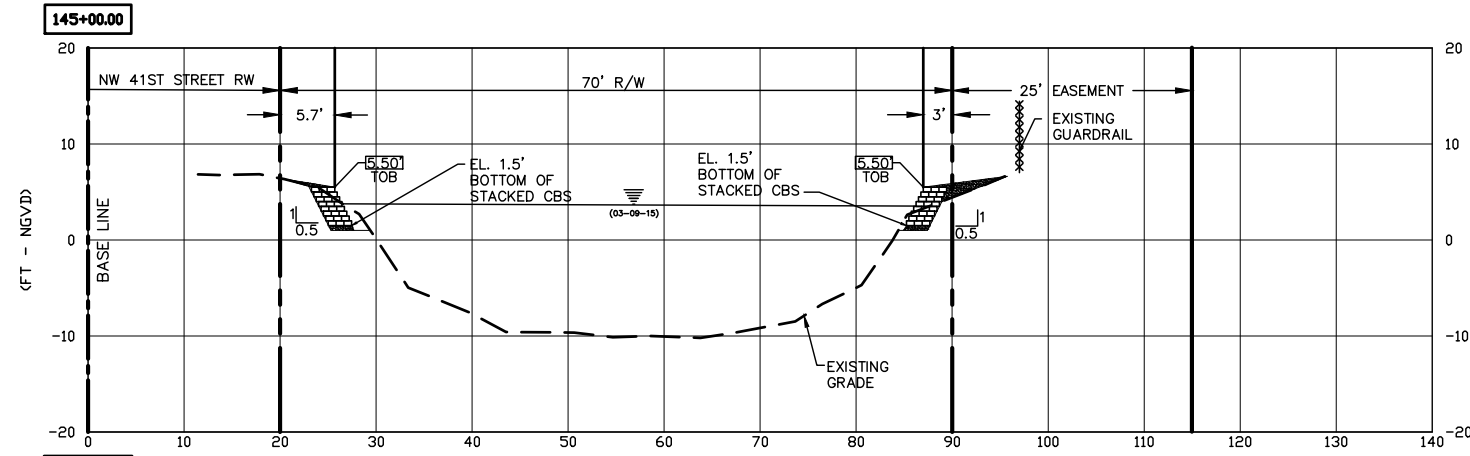
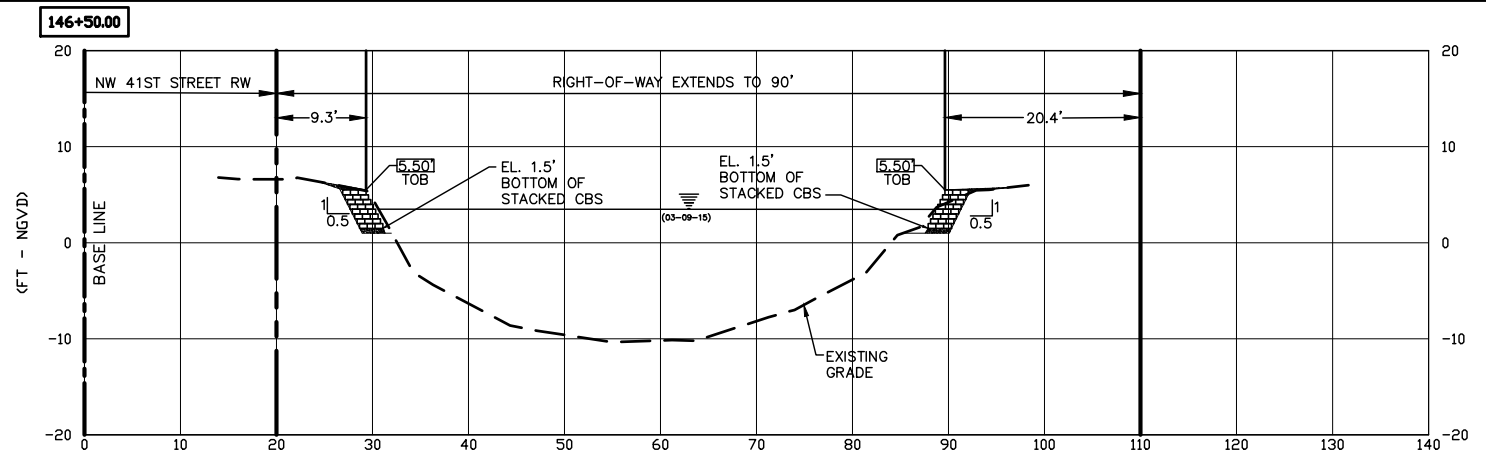
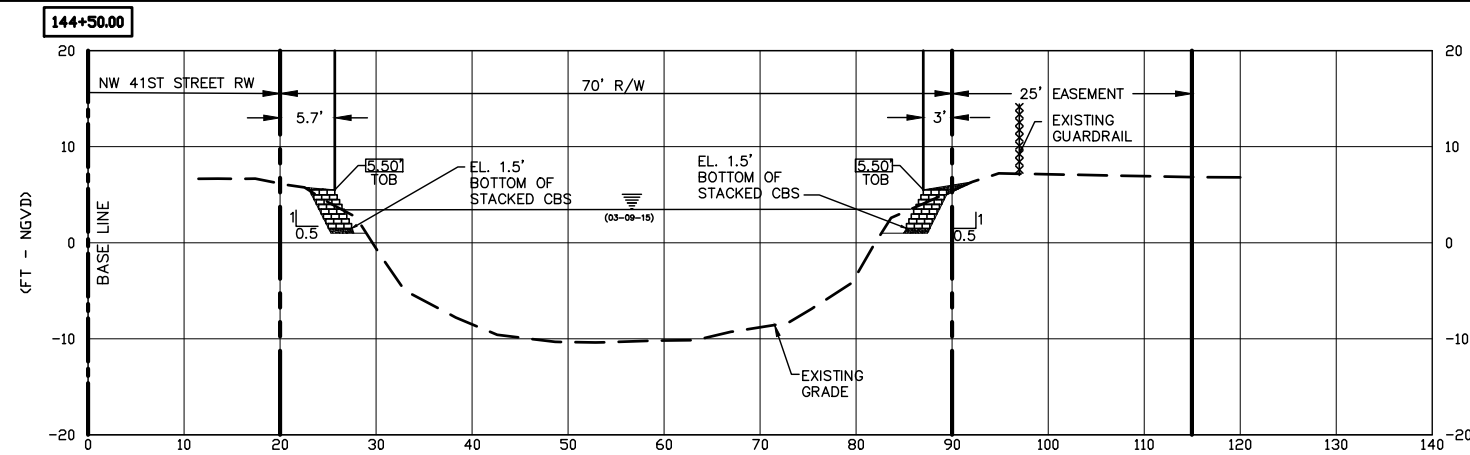

SCALE: 1" = 20' HORIZONTAL  
1" = 20' VERTICAL

**REVISIONS**

DATE	BY	DESCRIPTION	DATE	BY	DESCRIPTION

8550 N.W. 33RD STREET • SUITE 202  
DORAL, FLORIDA 33122  
PHONE (305) 551-4608 • FAX (305) 551-8977  
WWW.ADAENG.NET EB # 00003212

BY:  
**JEFFREY VOLLAT**  
P.E. No. 63930  
CIVIL ENG. STATE OF FL.



**CITY OF DORAL**  
**CANAL BANK RESTORATION**  
**PROGRAM - FISCAL YEAR 5**  
**(PHASE II)**

DATE: 06/2020  
SCALE: AS SHOWN  
CADD FILE: 02 GNRL-NOTES  
DESIGN BY: J.V.  
DRAWN BY: M.K.  
CHECKED BY: C.O.

**DRESSELS CANAL**  
**STA. 144+50 TO 148+00**  
**CANAL CROSS SECTIONS**



P:\Projects\173 City of Doral\0514\_Canal Bank Stabilization Program Management\01\_Year 5 Design\05\_Drawings\Year 5A - Phase II\22-37\_CROS-SECT\_YR-5.dwg Jun 11, 2020 - 3:18pm CORTEGA

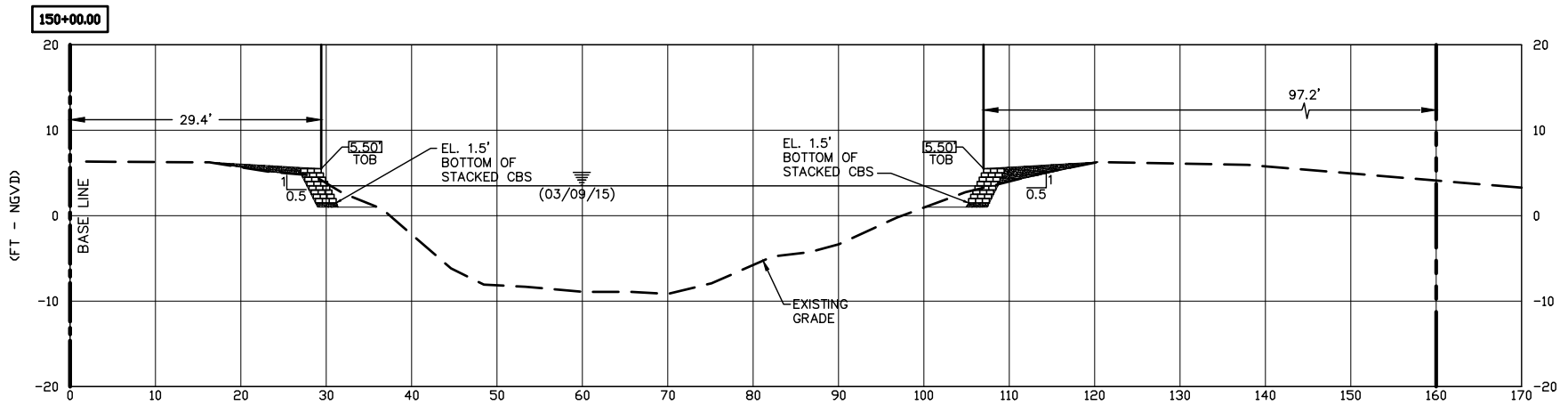
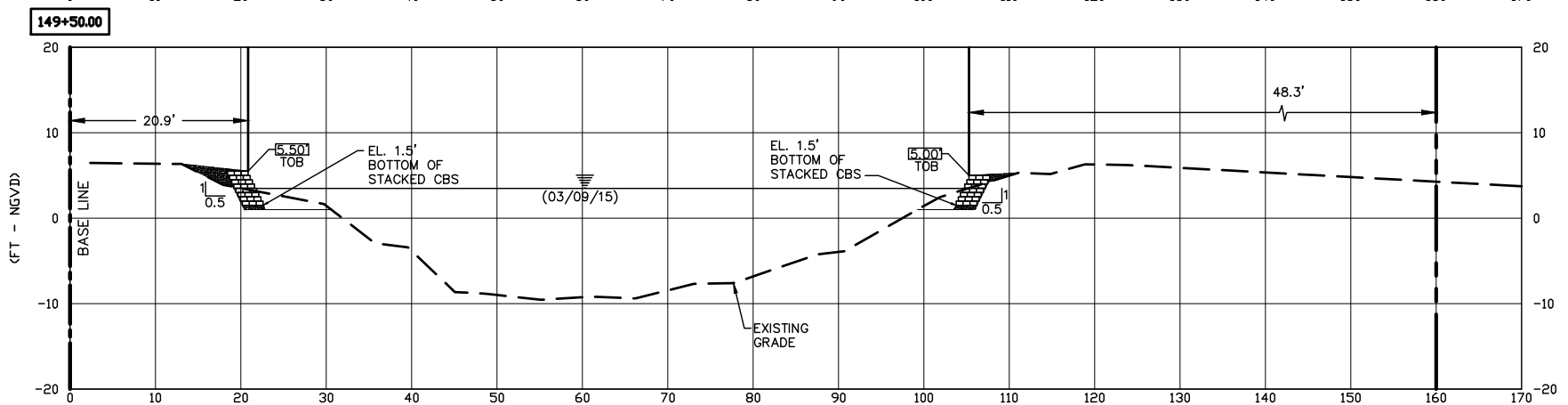
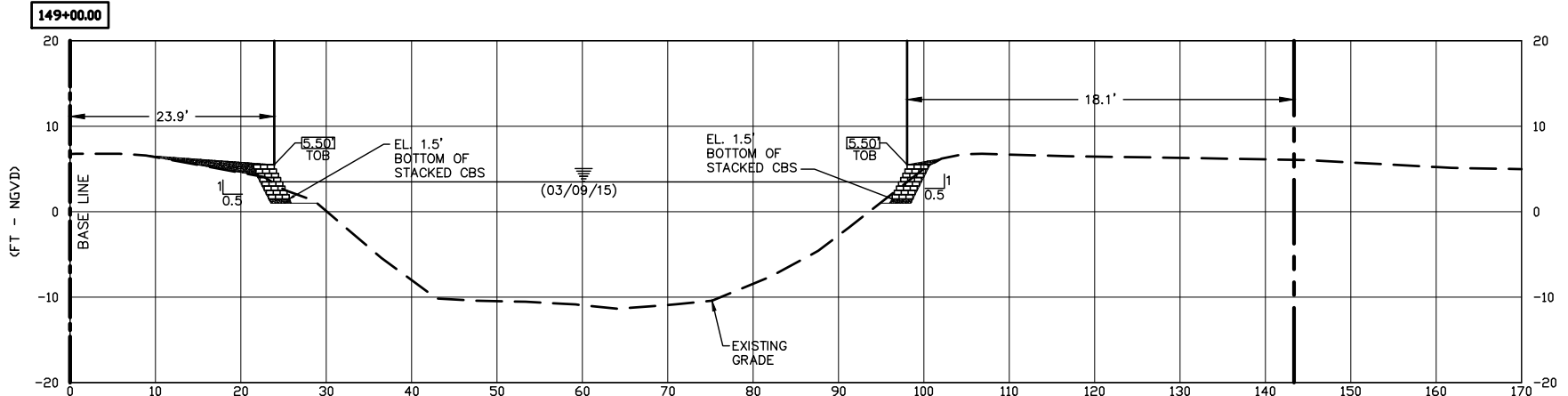
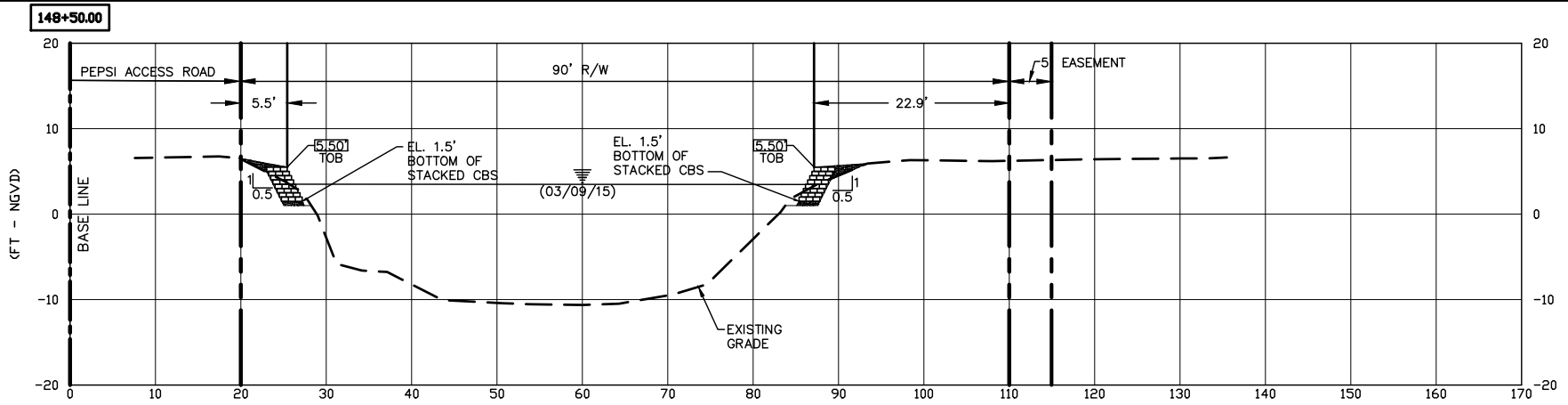

SCALE: 1" = 20' HORIZONTAL  
1" = 20' VERTICAL

**REVISIONS**

DATE	BY	DESCRIPTION	DATE	BY	DESCRIPTION

8550 N.W. 33RD STREET • SUITE 202  
DORAL, FLORIDA 33122  
PHONE (305) 551-4608 • FAX (305) 551-8977  
WWW.ADAENG.NET EB # 00003212

BY: JEFFREY VOLLAT  
P.E. No. 63930  
CIVIL ENG. STATE OF FL.



**CITY OF DORAL  
CANAL BANK RESTORATION  
PROGRAM - FISCAL YEAR 5  
(PHASE II)**

DATE: 06/2020  
SCALE: AS SHOWN  
CADD FILE: 02 GNRL-NOTES  
DESIGN BY: J.V.  
DRAWN BY: M.K.  
CHECKED BY: C.O.

**DRESSELS CANAL  
STA. 148+50 TO 152+00  
CANAL CROSS SECTIONS**

SHEET  
**36**  
OF 54

P:\Projects\173 City of Doral\0514\_Canal Bank Stabilization Program Management\01\_Year 5 Design\05\_Drawings\Year 5A - Phase II\22-37\_CROS-SECT\_IR-5.dwg Jun 11, 2020 - 3:18pm CORTEGA

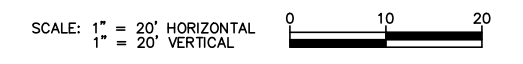
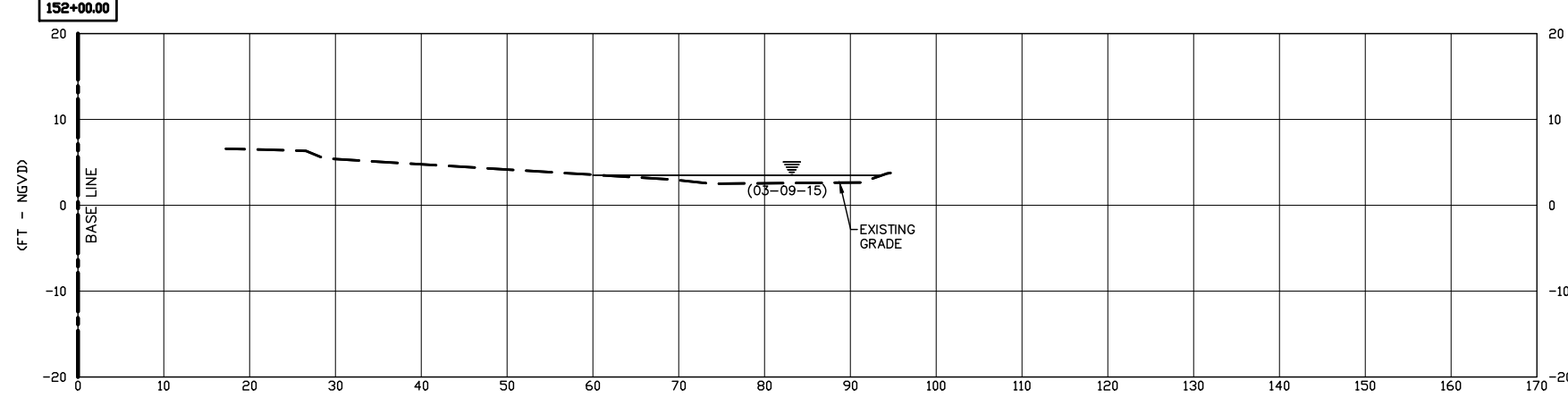
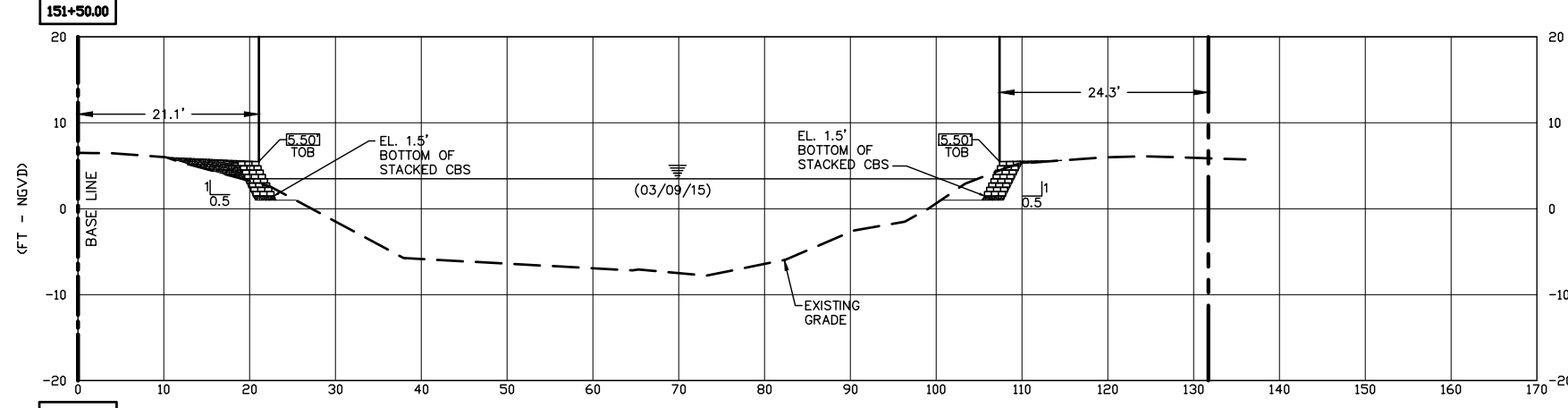
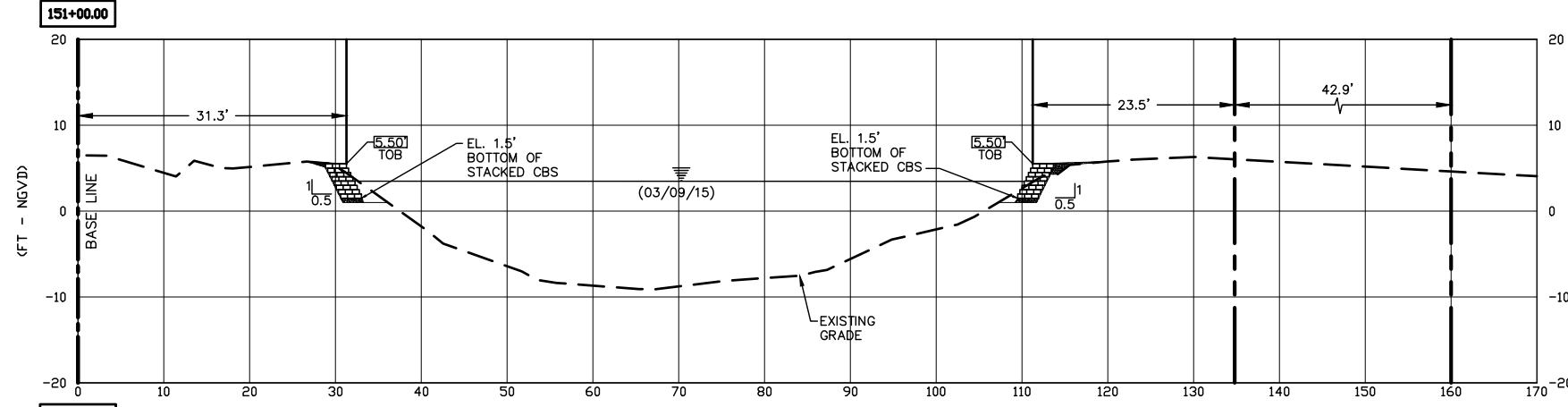
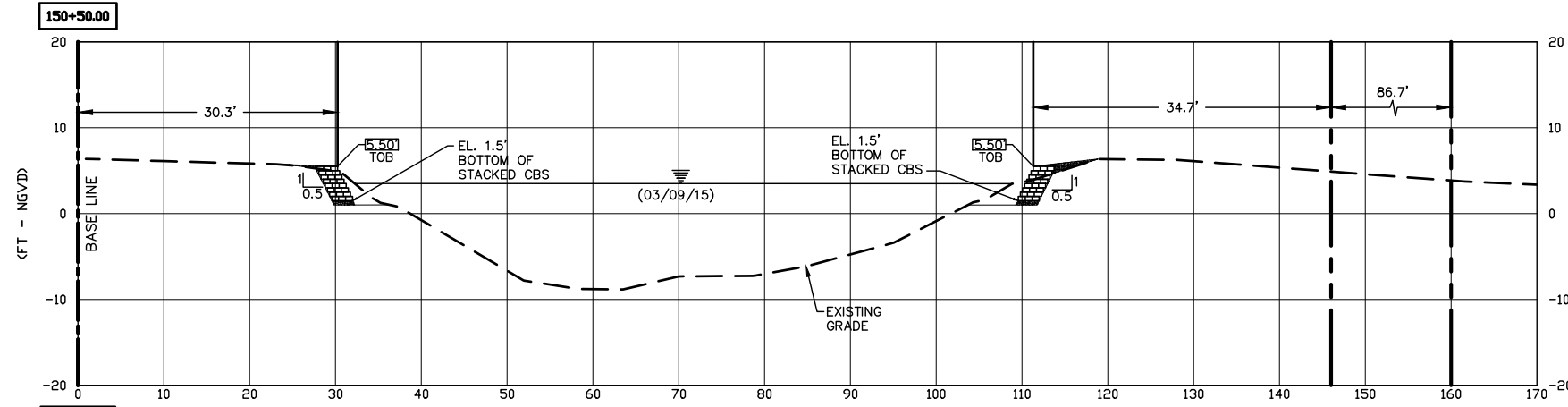

**REVISIONS**

DATE	BY	DESCRIPTION	DATE	BY	DESCRIPTION

8550 N.W. 33RD STREET • SUITE 202  
 DORAL, FLORIDA 33122  
 PHONE (305) 551-4608 • FAX (305) 551-8977  
 WWW.ADAENG.NET EB # 00003212

BY:  
**JEFFREY VOLLAT**  
 P.E. No. 63930  
 CIVIL ENG. STATE OF FL.

**CITY OF DORAL**  
**CANAL BANK RESTORATION**  
**PROGRAM - FISCAL YEAR 5**  
**(PHASE II)**

DATE: 06/2020	SCALE: AS SHOWN	CADD FILE: 02 GNRL-NOTES
DESIGN BY: J.V.	DRAWN BY: M.K.	CHECKED BY: C.O.

**DRESSELS CANAL**  
**STA. 148+50 TO 152+00**  
**CANAL CROSS SECTIONS**

P:\Projects\173 City of Doral\0514\_Canal Bank Stabilization Program Management\01\_Year 5 Design\05\_Details\Year 5A - Phase II\38-45\_DETAILS\_YR-5.dwg Jun 11, 2020 - 3:49pm CORTECA

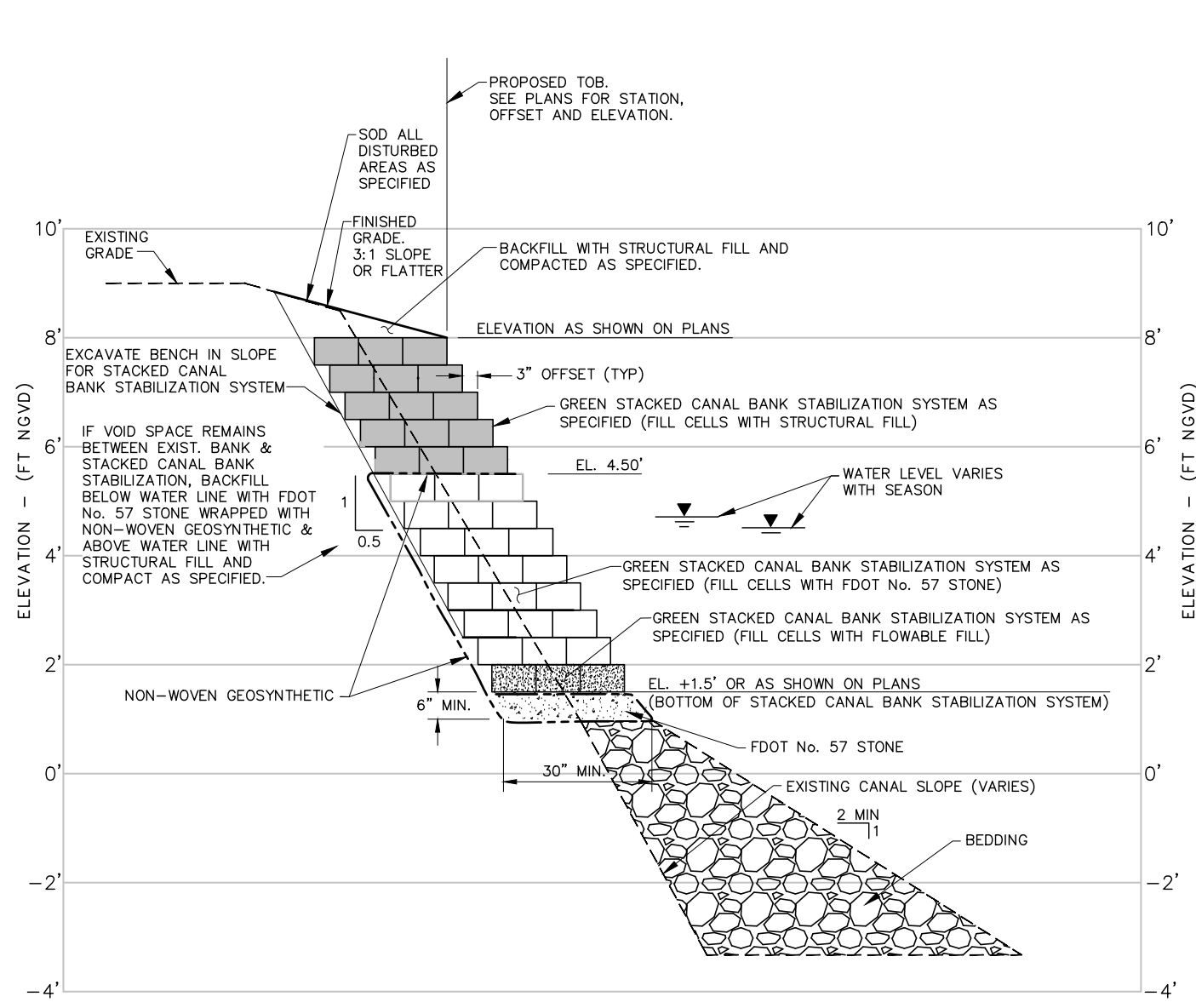

**1** STACKED CANAL BANK STABILIZATION (CBS) WITH BEDDING STONE DETAIL  
 SCALE: 1" = 3' HORIZONTAL  
 1" = 3' VERTICAL

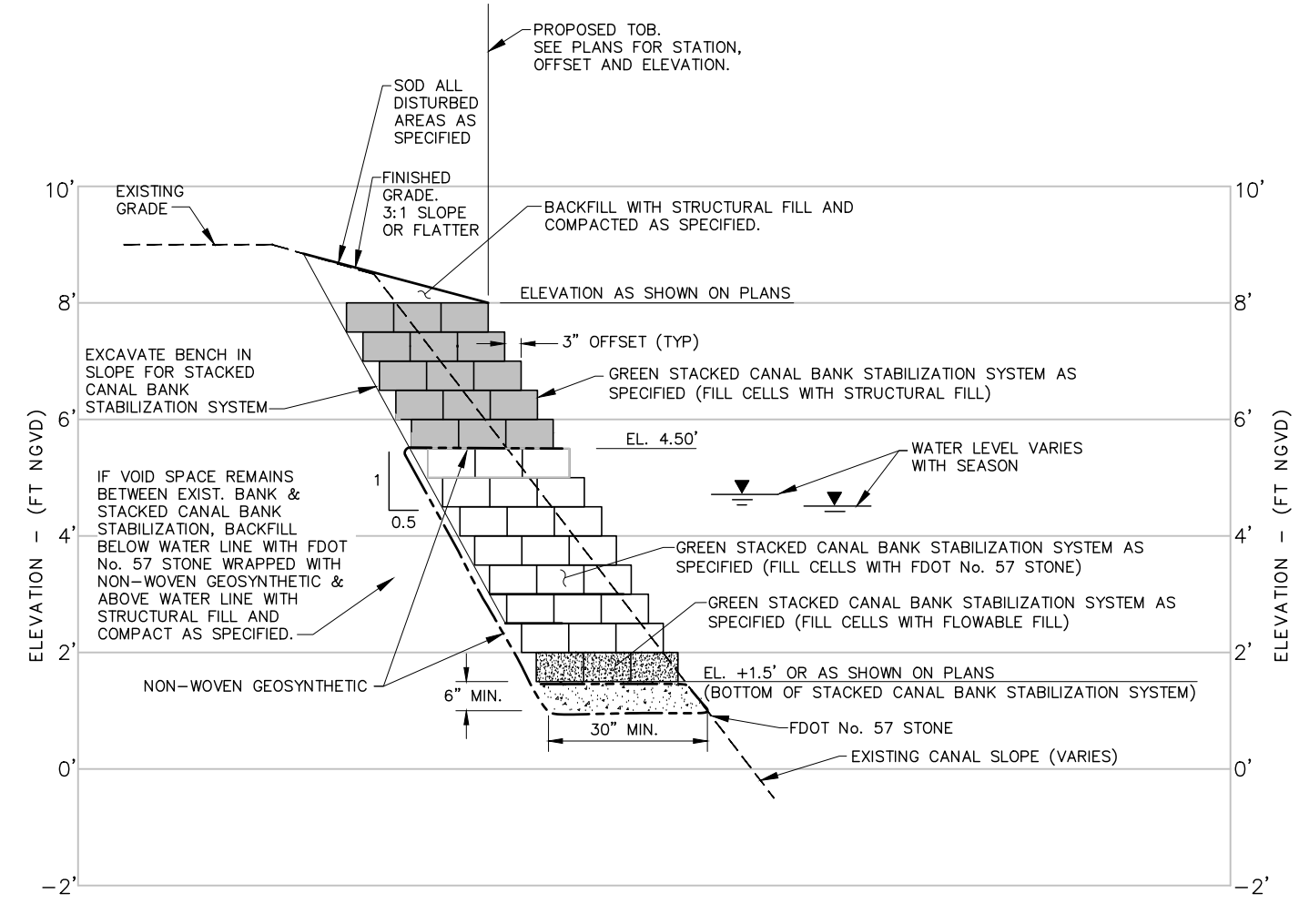

**2** STACKED CANAL BANK STABILIZATION (CBS) DETAIL  
 SCALE: 1" = 3' HORIZONTAL  
 1" = 3' VERTICAL

REVISIONS					
DATE	BY	DESCRIPTION	DATE	BY	DESCRIPTION

 8550 N.W. 33RD STREET • SUITE 202  
 DORAL, FLORIDA 33122  
 PHONE (305) 551-4608 • FAX (305) 551-8977  
 WWW.ADAENG.NET EB # 00003212

BY: **JEFFREY VOLLAT**  
 P.E. No. 63930  
 CIVIL ENG. STATE OF FL.



**CITY OF DORAL**  
**CANAL BANK RESTORATION**  
**PROGRAM - FISCAL YEAR 5**  
**(PHASE II)**

DATE: 06/2020	SCALE: AS SHOWN	CADD FILE: 30-33 DETAILS
DESIGN BY: J.V.	DRAWN BY: M.K.	CHECKED BY: C.O.

**GEOWEB DETAILS**

SHEET **38**  
OF 54

P:\Projects\173 City of Doral\0514\_Canal Bank Stabilization Program Management\01\_Year 5 Design\05\_Details\_YR-5.dwg Year 5A - Phase II\38-45\_DETAILS\_YR-5.dwg Jun 11, 2020 - 3:49pm CORTECA

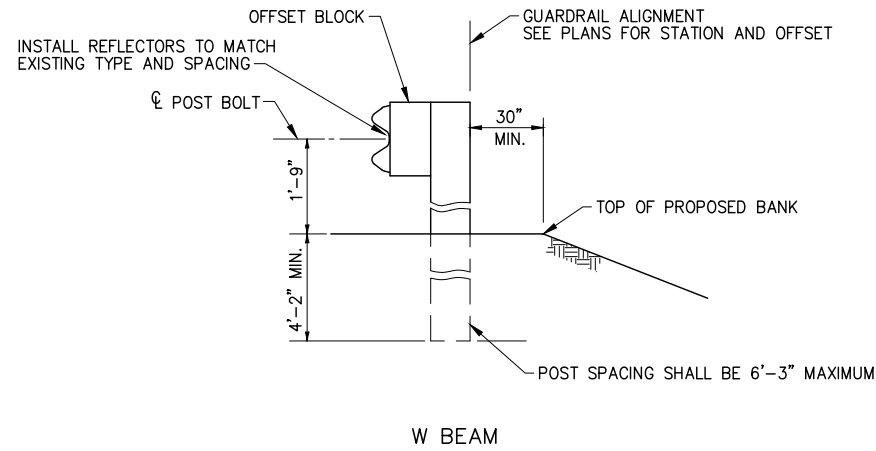

POST	OFFSET BLOCK	REMARKS
STEEL W6 x 8.5 AND 6" C	6" x 8" & 5" x 8" (NOMINAL) x 14" TIMBER W6 x 8.5 x 14" & 6" C x 14" STEEL TO MATCH POST.	SAME AS ABOVE 5/8"Ø x 1½" GALV. HEX HEAD BOLTS WITH FULL LENGTH THREAD AND NUTS (2 REQ'D.) AND WASHERS (4 REQ'D) FOR MOUNTING STEEL BLOCK TO POST. BOLTS ARE TO BE INSTALLED IN OPPOSITE HOLES, TOP AND BOTTOM.
NOTE: THE BEAM BLOCKS ARE 22" IN LENGTH.		

NOTE: AT GUARD RAIL TERMINATION USE END ANCHORAGE ASSEMBLY TYPE II, SEE FDOT INDEX 400 AND DETAIL 21 ON SHEET 43.

**4 GUARDRAIL DETAIL**  
N.T.S.

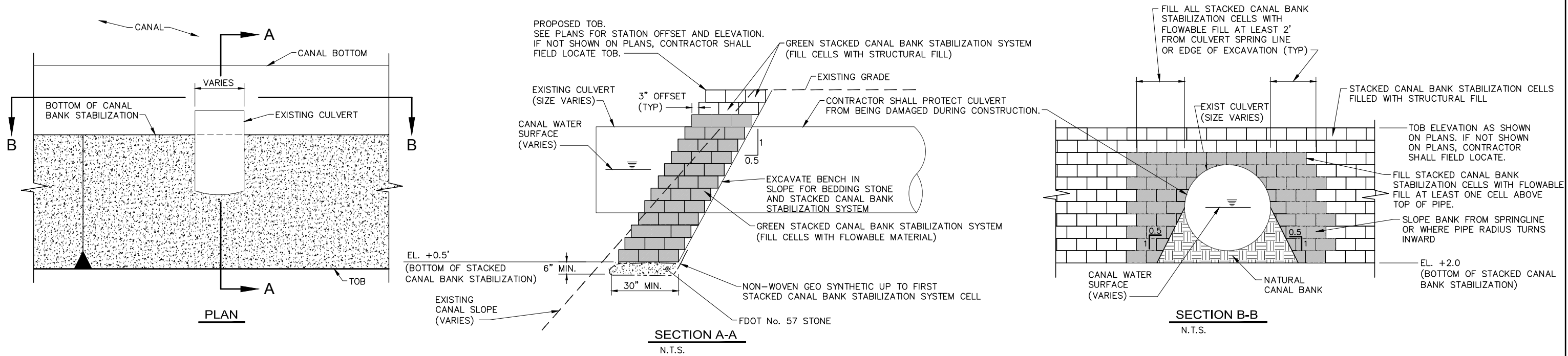

**5 STACKED CANAL BANK STABILIZATION (CBS) - WRAP AROUND EXISTING CULVERT DETAIL**  
N.T.S.

REVISIONS

DATE	BY	DESCRIPTION	DATE	BY	DESCRIPTION

8550 N.W. 33RD STREET • SUITE 202  
 DORAL, FLORIDA 33122  
 PHONE (305) 551-4608 • FAX (305) 551-8977  
 WWW.ADAENG.NET EB # 00003212

BY: **JEFFREY VOLLAT**  
 P.E. No. 63930  
 CIVIL ENG. STATE OF FL.



**CITY OF DORAL**  
**CANAL BANK RESTORATION**  
**PROGRAM - FISCAL YEAR 5**  
**(PHASE II)**

DATE: 06/2020	SCALE: AS SHOWN	CADD FILE: 30-33 DETAILS
DESIGN BY: J.V.	DRAWN BY: M.K.	CHECKED BY: C.O.

DETAILS

P:\Projects\173 City of Doral\0514\_Canal Bank Stabilization Program Management\01\_Year 5 Design\05\_Details\_YR-5.dwg Year 5A - Phase II\38-45\_DETAILS\_YR-5.dwg Jun 11, 2020 - 3:49pm CORTECA

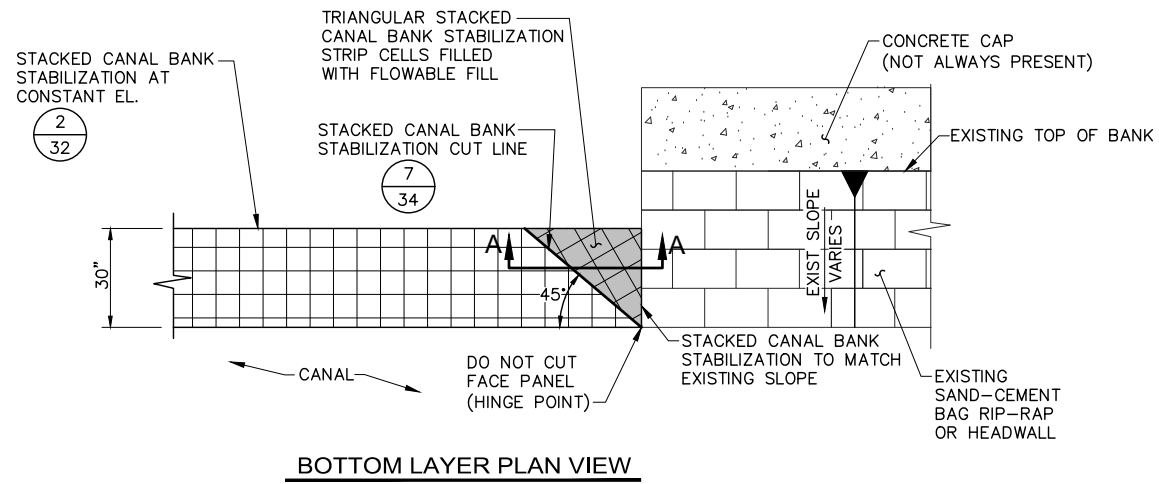

**7** BOTTOM LAYER PLAN VIEW

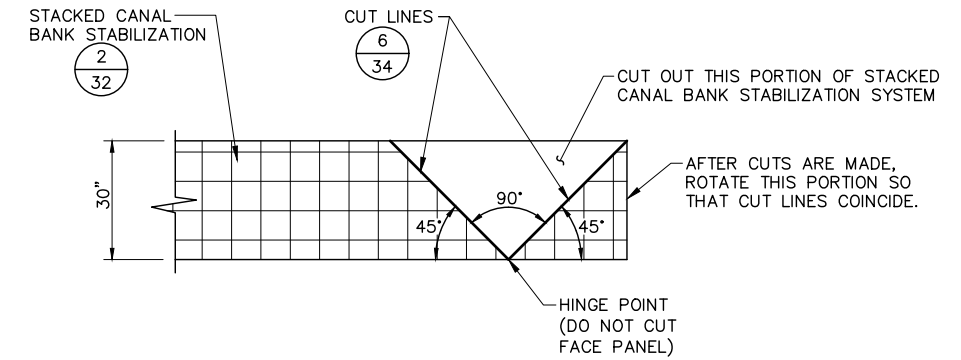

**7** STACKED CANAL BANK STABILIZATION (CBS) CUT LINE HINGE DETAIL  
N.T.S.

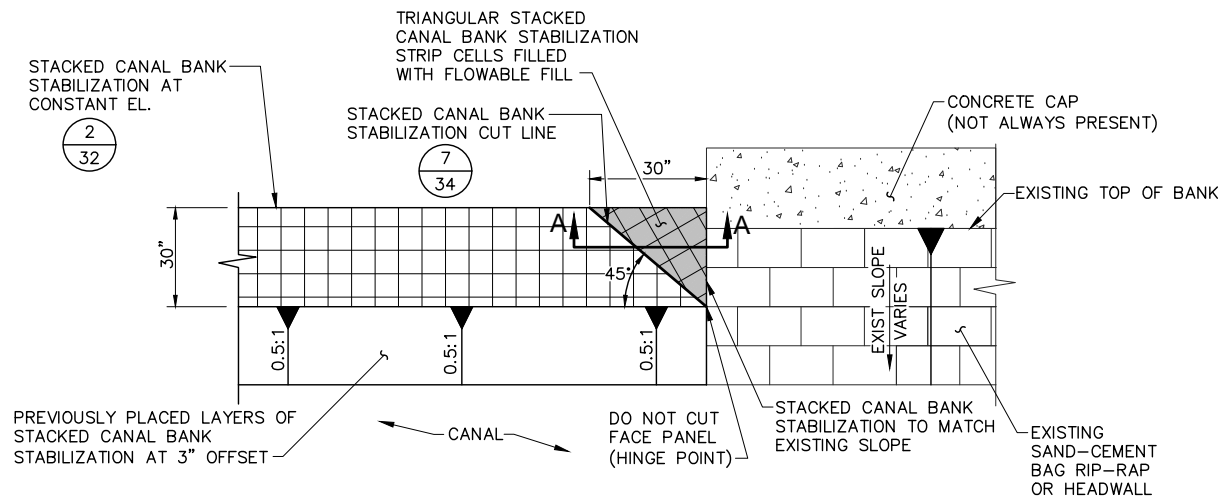

**6** INTERMEDIATE LAYER PLAN VIEW (MULTIPLE)

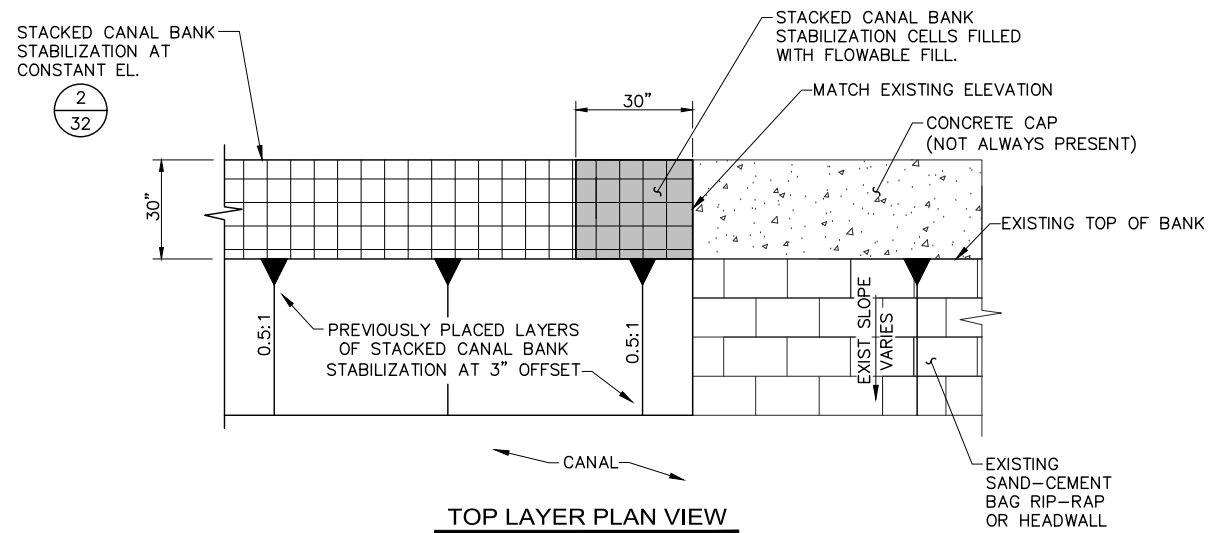

**6** TOP LAYER PLAN VIEW

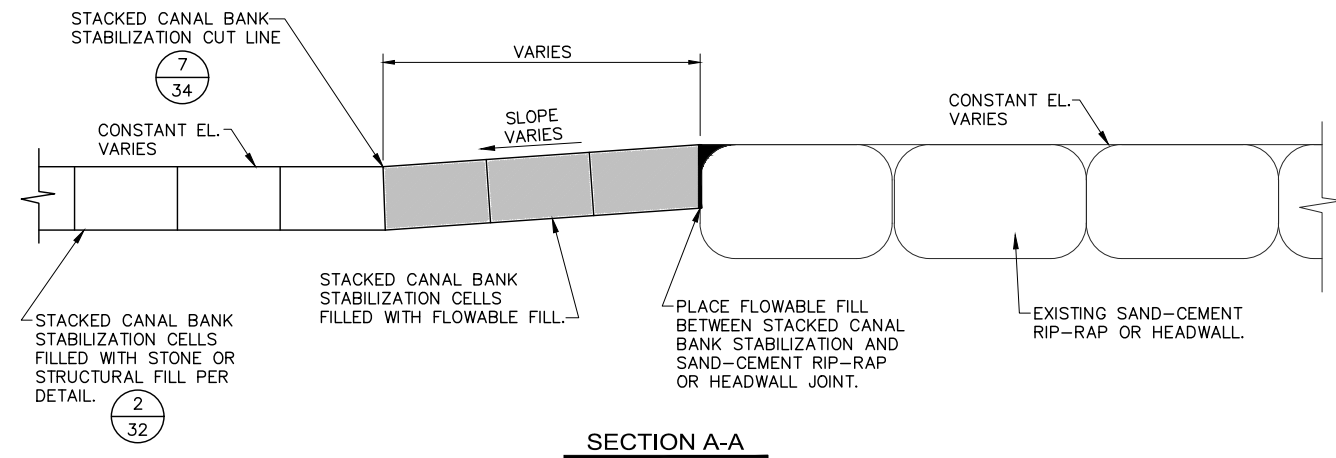

**6** SECTION A-A

**6** STACKED CANAL BANK STABILIZATION (CBS) - TIE-IN TO EXISTING HEADWALL DETAIL  
N.T.S.

**REVISIONS**

DATE	BY	DESCRIPTION	DATE	BY	DESCRIPTION

 8550 N.W. 33RD STREET • SUITE 202  
 DORAL, FLORIDA 33122  
 PHONE (305) 551-4608 • FAX (305) 551-8977  
 WWW.ADAENG.NET EB # 00003212

BY:  
**JEFFREY VOLLAT**  
 P.E. No. 63930  
 CIVIL ENG. STATE OF FL.



**CITY OF DORAL**  
**CANAL BANK RESTORATION**  
**PROGRAM - FISCAL YEAR 5**  
**(PHASE II)**

DATE: 06/2020	SCALE: AS SHOWN	CADD FILE: 30-33 DETAILS
DESIGN BY: J.V.	DRAWN BY: M.K.	CHECKED BY: C.O.

**DETAILS**

P:\Projects\173 City of Doral\0514\_Canal Bank Stabilization Program Management\01\_Year 5 Design\05\_Details\Year 5A - Phase II\38-45\_DETAILS\_YR-5.dwg Jun 11, 2020 - 3:49pm CORTECA

**LEGEND**

- PILE LOCATIONS
- ▨ DREDGE OR FILL AREA
- MOORING BUOY W/ANCHOR
- ┴— ANCHOR
- BARRIER MOVEMENT DUE TO CURRENT ACTION

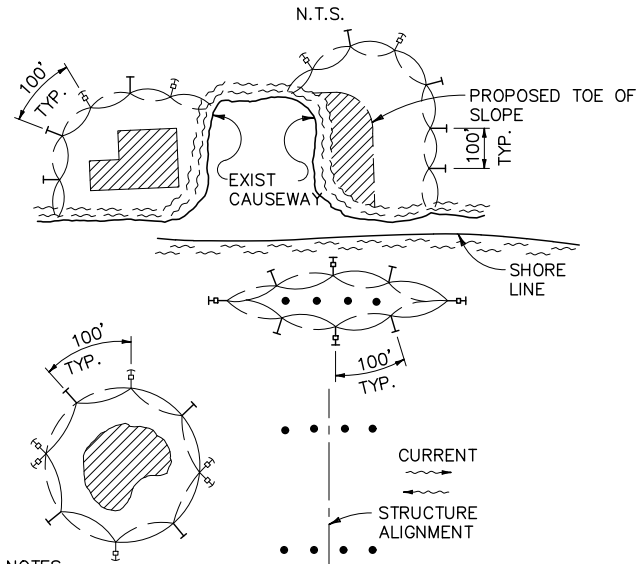

**NOTES:**

1. TURBIDITY BARRIERS ARE TO BE USED IN ALL PERMANENT BODIES OF WATER REGARDLESS OF WATER DEPTH.
2. NUMBER AND SPACING OF ANCHORS DEPENDENT ON CURRENT VELOCITIES.
3. DEPLOYMENT OF BARRIER AROUND PILE LOCATIONS MAY VARY TO ACCOMMODATE CONSTRUCTION OPERATIONS.
4. NAVIGATION MAY REQUIRE SEGMENTING BARRIER DURING CONSTRUCTION OPERATIONS.

**TURBIDITY BARRIER APPLICATIONS**

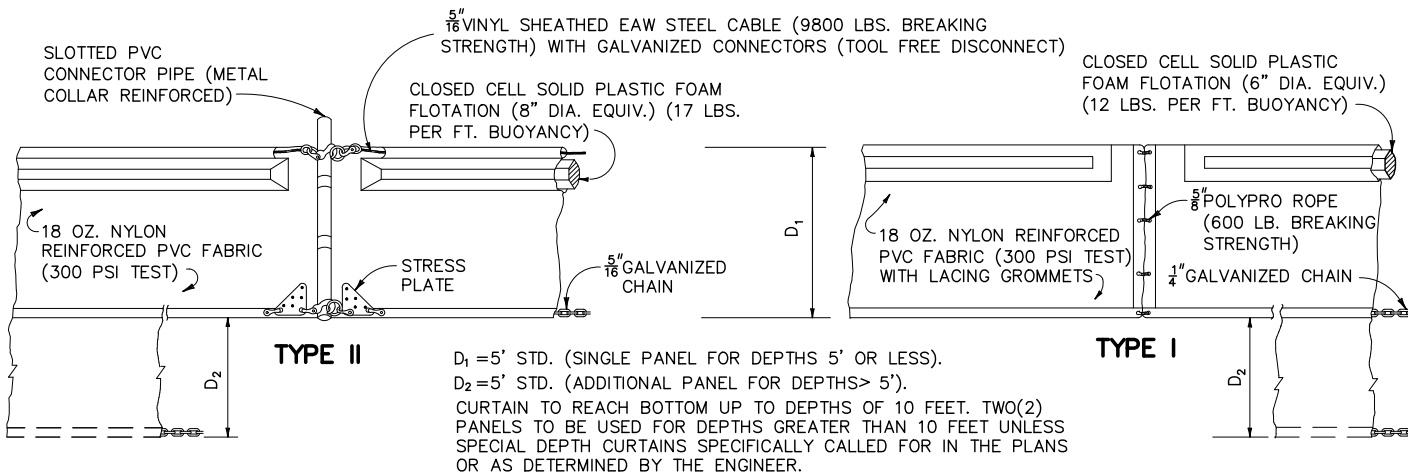

NOTICE: COMPONENTS OF TYPES ~ AND ~ MAY BE SIMILAR OR IDENTICAL TO PROPRIETARY DESIGNS. ANY INFRINGEMENT ON THE PROPRIETARY RIGHTS OF THE DESIGNER SHALL BE THE SOLE RESPONSIBILITY OF THE USER. SUBSTITUTIONS FOR TYPES ~ AND ~ SHALL BE AS APPROVED BY THE ENGINEER.

**TURBIDITY BARRIER DETAIL**

**8 FLOATING TURBIDITY BARRIER DETAIL**  
N.T.S.

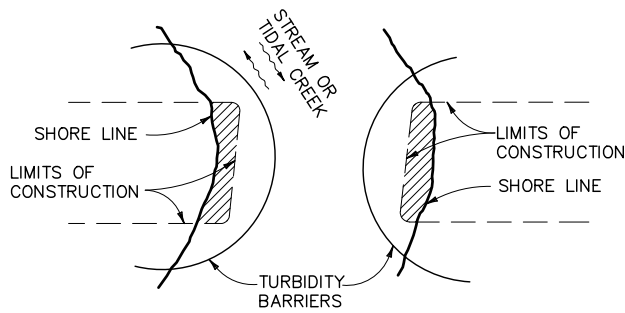

**NOTE:**

TURBIDITY BARRIERS FOR FLOWING STREAMS, CANALS AND TIDAL CREEKS MAY BE EITHER FLOATING, OR STAKED TYPES OR ANY COMBINATIONS OF TYPES THAT WILL SUIT SITE CONDITIONS AND MEET EROSION CONTROL AND WATER QUALITY REQUIREMENTS. THE BARRIER TYPE(S) WILL BE AT THE CONTRACTORS OPTION UNLESS OTHERWISE SPECIFIED IN THE PLANS. POSTS IN STAKED TURBIDITY BARRIERS TO BE INSTALLED IN VERTICAL POSITION UNLESS OTHERWISE DIRECTED BY THE ENGINEER.

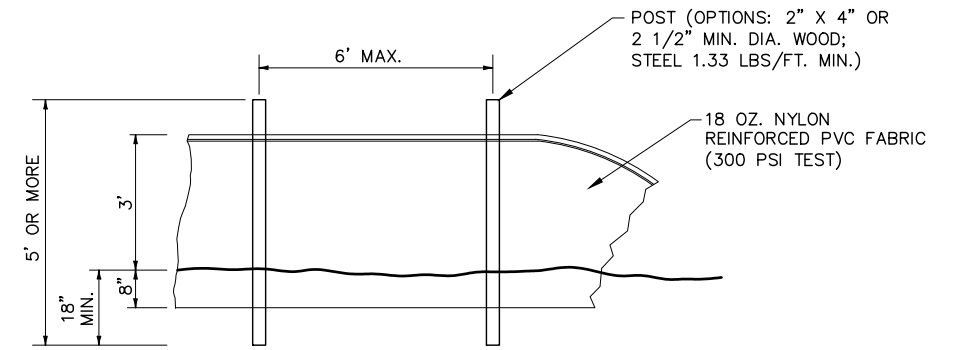

**9 STAKED TURBIDITY BARRIER DETAIL**  
N.T.S.

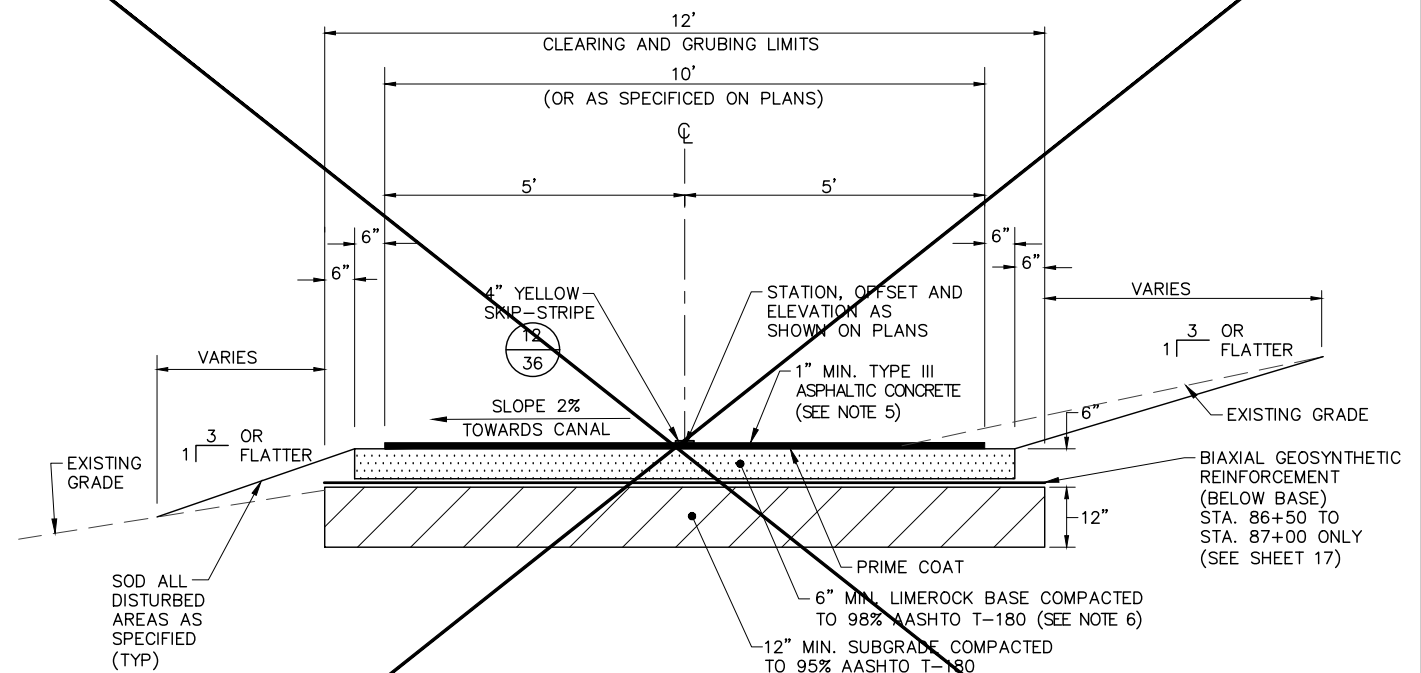

**10 BICYCLE/PEDESTRIAN PATH DETAIL**  
N.T.S.

**NOTES:**

1. BICYCLE/PEDESTRIAN PATHS SHALL BE 10 FEET WIDE UNLESS NOTED OTHERWISE ON PLANS.
2. ALL ROOTS, MUCK, AND OTHER UNSUITABLE MATERIALS SHALL BE REMOVED TO A DEPTH OF 12" BELOW THE BASE ROCK.
3. ASPHALT DENSITY SHALL BE 94% OF MAXIMUM LAB DENSITY.
4. BICYCLE/ PEDESTRIAN PATH LONGITUDINAL SLOPE SHALL BE 1:12 OR FLATTER.
5. ASPHALTIC CONCRETE THICKNESS SHALL BE 2.5" MIN. FOR THICKENED PAVEMENT SECTION WHEN SHOWN ON PLANS.
6. LIMEROCK BASE SHALL BE 8" MIN. FOR THICKENED PAVEMENT SECTION WHEN SHOWN ON PLANS.

**REVISIONS**

DATE	BY	DESCRIPTION	DATE	BY	DESCRIPTION

8550 N.W. 33RD STREET • SUITE 202  
DORAL, FLORIDA 33122  
PHONE (305) 551-4608 • FAX (305) 551-8977  
WWW.ADAENG.NET EB # 00003212

BY:  
**JEFFREY VOLLAT**  
P.E. No. 63930  
CIVIL ENG. STATE OF FL.



**CITY OF DORAL**  
**CANAL BANK RESTORATION**  
**PROGRAM - FISCAL YEAR 5**  
**(PHASE II)**

DATE: 06/2020	SCALE: AS SHOWN	CADD FILE: 30-33 DETAILS
DESIGN BY: J.V.	DRAWN BY: M.K.	CHECKED BY: C.O.

**DETAILS**

P:\Projects\173 City of Doral\0514\_Canal Bank Stabilization Program Management\01\_Year 5 Design\05\_Details\_YR-5.dwg Jun 11, 2020 - 3:53pm CORTECA

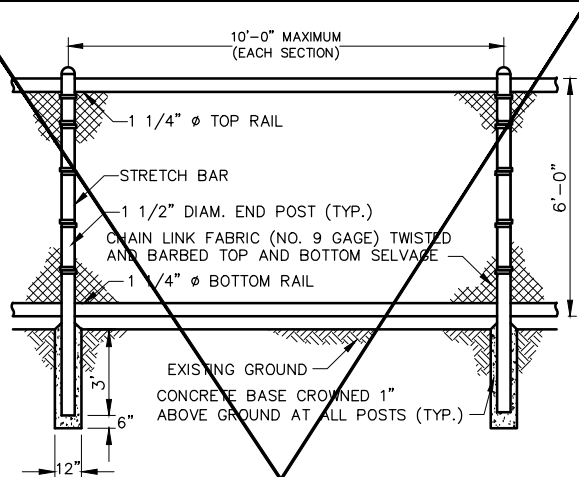

- NOTES:**
1. EACH SECTION SHALL HAVE (2) END POST, (1) TOP RAIL, (1) BOTTOM RAIL AND WIRE MESH.
  2. POSTS AND RAILS SHALL BE GALVANIZED STEEL OR ALUMINUM.
  3. WIRE MESH SHALL BE GALVANIZED, AS WELL AS ALL FITTINGS AND HARDWARE.
  4. PERMIT REQUIRED FROM THE BUILDING AND ZONING DEPARTMENT FOR INSTALLATION.

**11 6' CHAIN LINK FENCE DETAIL**  
N.T.S.

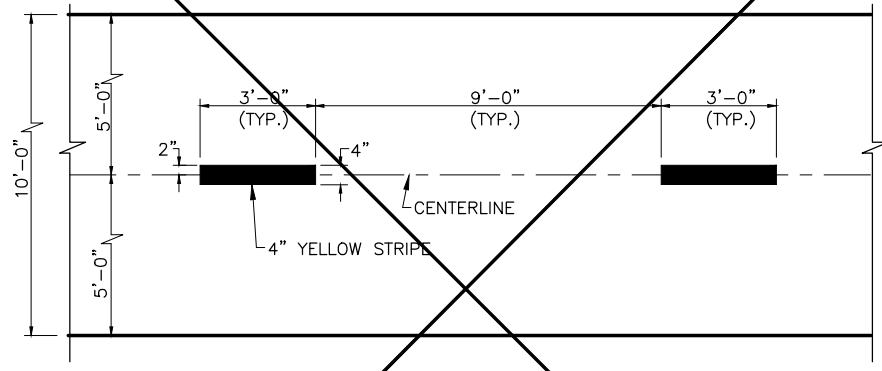

**12 BICYCLE/PEDESTRIAN PATH MARKINGS**  
YELLOW IN COLOR  
N.T.S.

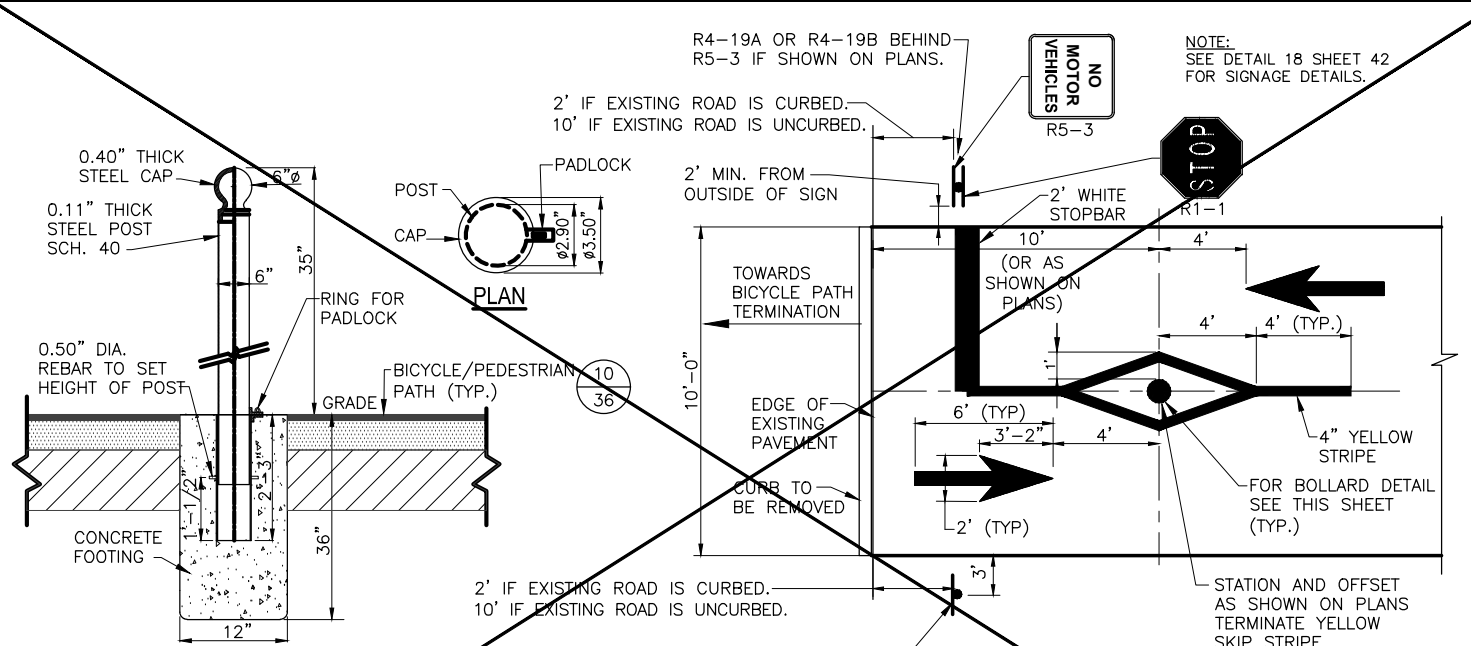

**14 BOLLARD, SIGNAGE AND BOLLARD PAVEMENT MARKING DETAIL**  
N.T.S.

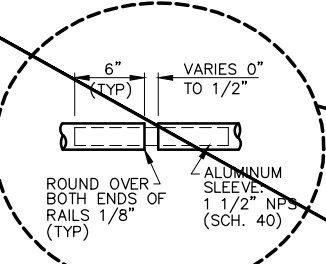

**RAIL EXPANSION JOINT DETAIL "B"**

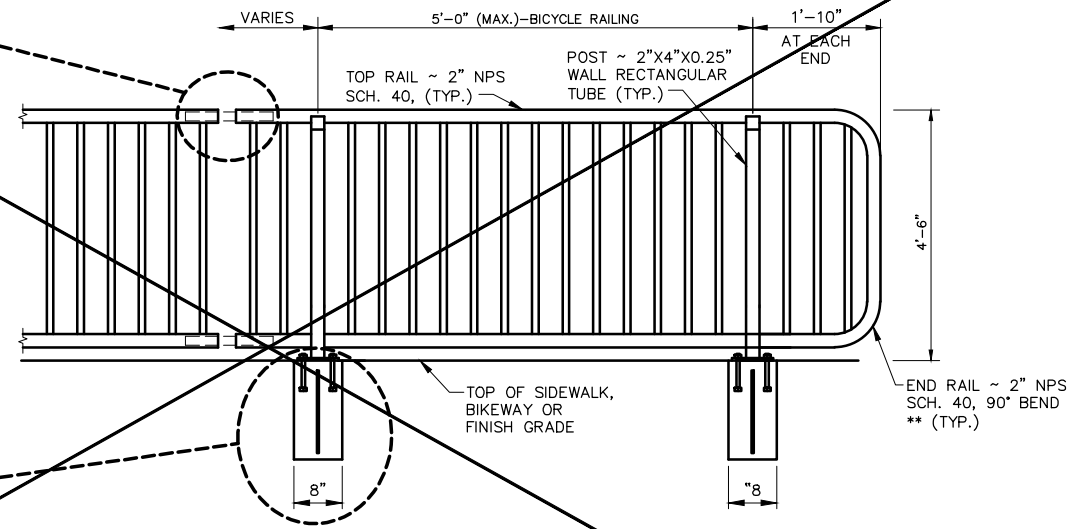

- NOTES:**
1. AS PER FDOT DESIGN STANDARD INDEX No. 860.
  2. CURVED SECTIONS TO BE DEVELOPED USING 8'-8" CHORDS.
  3. INSTALL BICYCLE RAILING A MINIMUM OF 2' FROM EDGE ON BICYCLE/PEDESTRIAN PATH.

**13 BICYCLE RAILING DETAIL**  
N.T.S.

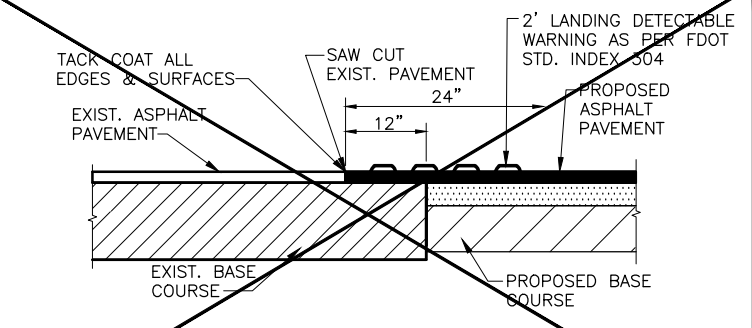

**15 TIE IN TO EXISTING PAVEMENT DETAIL**  
N.T.S.

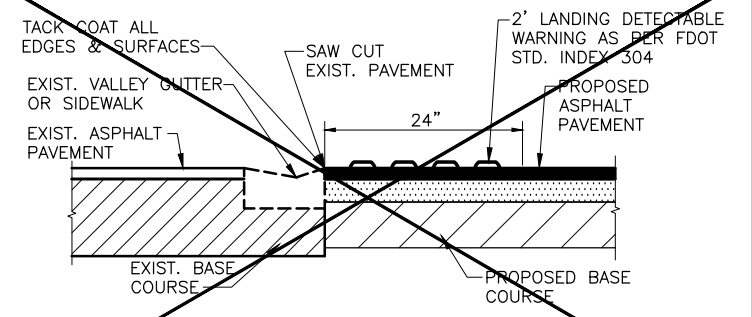

**16 TIE IN TO EXISTING CURB AND GUTTER DETAIL**  
N.T.S.

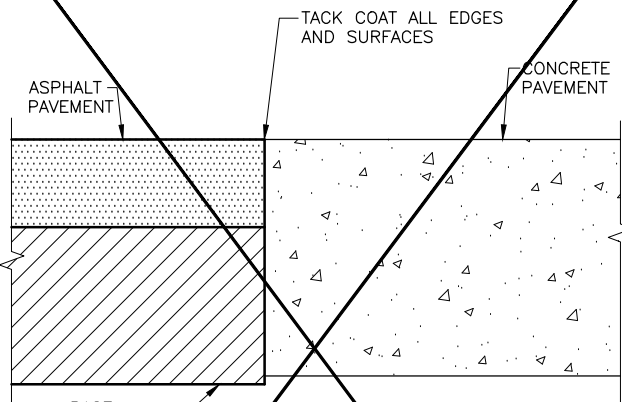

**17 CONCRETE TO ASPHALT JOINT DETAIL**  
N.T.S.

**CAST-IN-PLACE ANCHOR BOLTS SHOWN, ADHESIVE ANCHORS SIMILAR) DETAIL "A"**

**REVISIONS**

DATE	BY	DESCRIPTION	DATE	BY	DESCRIPTION
8/6/10	A.V.	SIGNAGE MODIFICATION			

**ADA**  
8550 N.W. 33RD STREET • SUITE 202  
DORAL, FLORIDA 33122  
PHONE (305) 551-4608 • FAX (305) 551-8977  
WWW.ADAENG.NET EB # 00003212

BY: **JEFFREY VOLLAT**  
P.E. No. 63930  
CIVIL ENG. STATE OF FL.



**CITY OF DORAL**  
CANAL BANK RESTORATION  
PROGRAM - FISCAL YEAR 5  
(PHASE II)

DATE:	SCALE:	CADD FILE:
06/2020	AS SHOWN	30-33 DETAILS
DESIGN BY:	DRAWN BY:	CHECKED BY:
J.V.	M.K.	C.O.

**DETAILS**

P:\Projects\173 City of Doral\0514\_Canal Bank Stabilization Program Management\01\_Year 5 Design\05\_Details\Year 5A - Phase II\38-45\_DETAILS\_YR-5.dwg Jun 11, 2020 - 3:49pm CORTECA

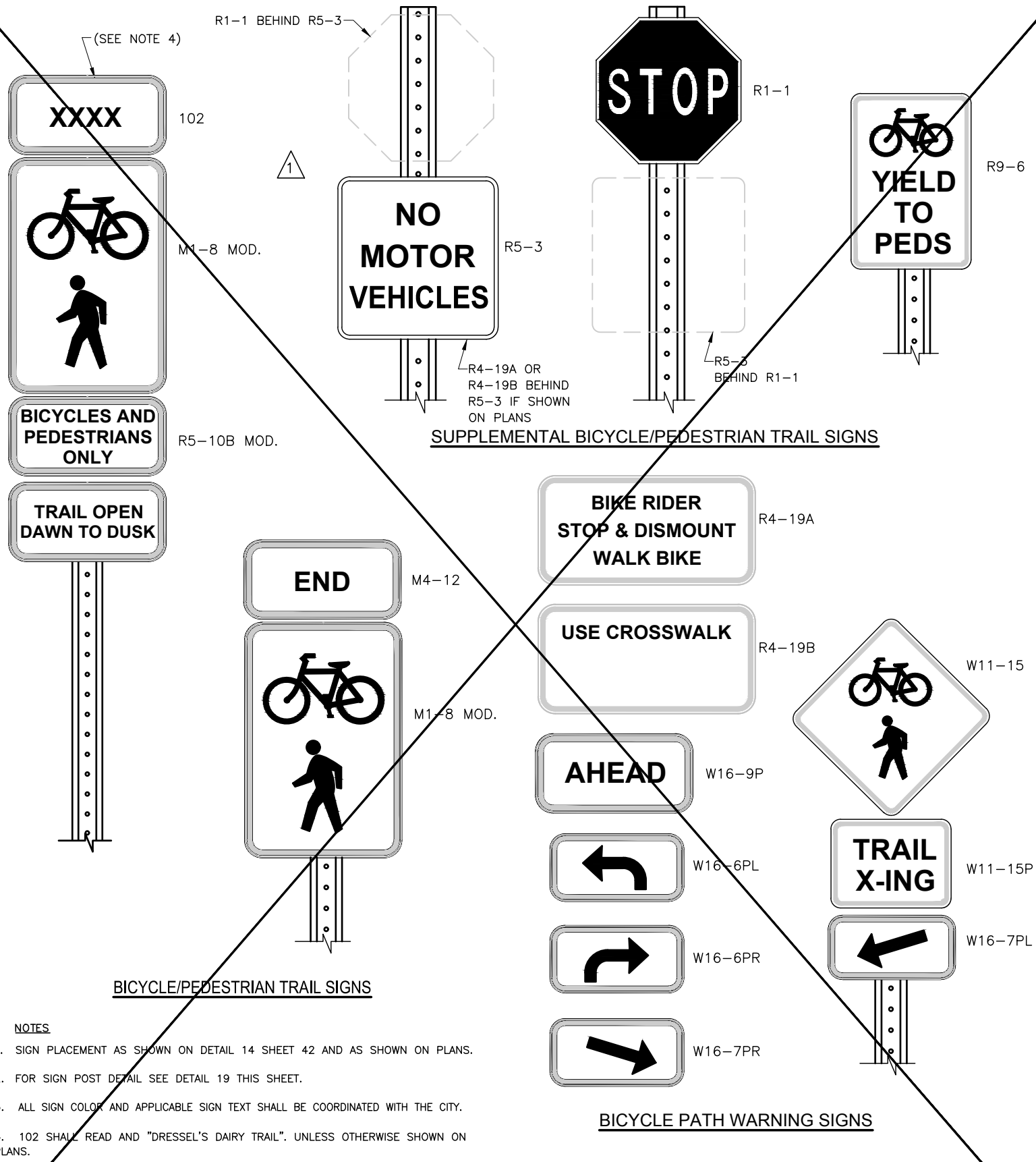

- NOTES**
- SIGN PLACEMENT AS SHOWN ON DETAIL 14 SHEET 42 AND AS SHOWN ON PLANS.
  - FOR SIGN POST DETAIL SEE DETAIL 19 THIS SHEET.
  - ALL SIGN COLOR AND APPLICABLE SIGN TEXT SHALL BE COORDINATED WITH THE CITY.
  - 102 SHALL READ AND "DRESSEL'S DAIRY TRAIL", UNLESS OTHERWISE SHOWN ON PLANS.

**18 BICYCLE/PEDESTRIAN SIGNAGE DETAILS**  
N.T.S.

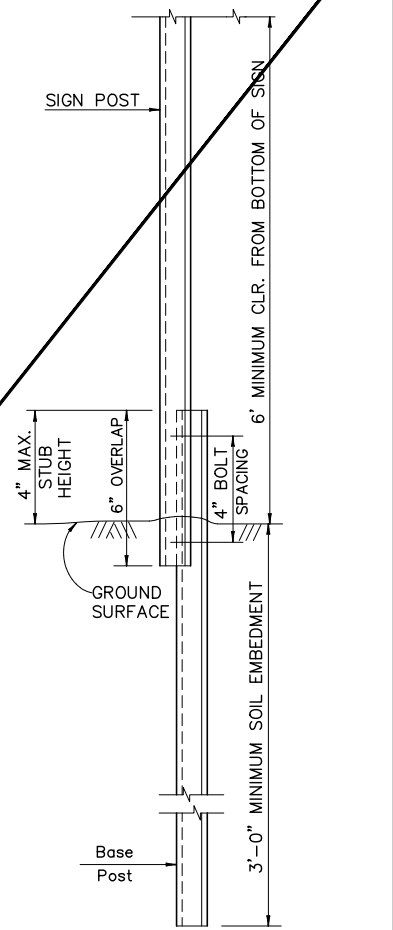
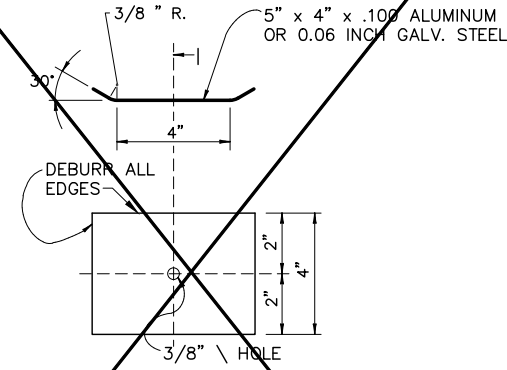
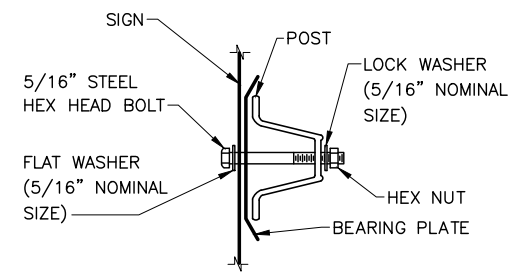
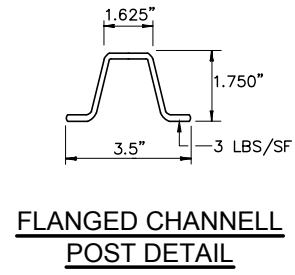
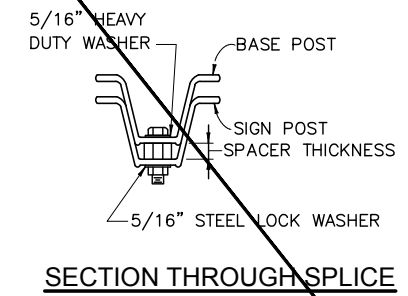

**SIGN ATTACHMENT DETAIL**

**BEARING PLATE DETAIL**

**SIGNPOST EMBEDMENT DETAIL**

- NOTES**
- STEEL FOR FLANGED CHANNEL POSTS SHALL CONFORM WITH ASTM A499 GRADE 60, OR ASTM A576 GRADE 1080.
  - BOLTS, NUTS AND WASHERS SHALL CONFORM TO ASTM A307.
  - ALL STEEL POSTS, PLATES, AND HARDWARE SHALL BE GALVANIZED PER ASTM A123 OR ASTM A153.
  - SPLICE REQUIREMENTS: BASE AND SIGN POSTS SHALL BE SAME SIZE & TYPE. SPLICE SHALL BE SIX INCHES IN LENGTH, FASTENED WITH TWO BOLTS FOUR INCHES APART, WITH WASHERS AND SPACER, AS SHOWN. BOLTS SHALL BE WRENCH-TIGHTENED SUFFICIENTLY TO CLAMP SPLICE ASSEMBLY TIGHTLY TOGETHER.
  - THE BASE POST SHALL BE INSTALLED TO LEAVE ONLY A 4-INCH STUB HEIGHT ABOVE GROUND.
  - ALL SPLICE COMPONENTS AND POST SHALL BE GALVANIZED PER ASTM A123 OR A153. FASTENERS MAY BE MECHANICALLY GALVANIZED TO ASTM B695 CLASS 50.

**19 SIGN POST DETAILS**  
N.T.S.

**REVISIONS**

DATE	BY	DESCRIPTION	DATE	BY	DESCRIPTION
8/6/10	A.V.	△ SIGNAGE MODIFICATION			
8/6/10	A.V.	△ NOTE MODIFICATION			

8550 N.W. 33RD STREET • SUITE 202  
DORAL, FLORIDA 33122  
PHONE (305) 551-4608 • FAX (305) 551-8977  
WWW.ADAENG.NET EB # D0003212

BY: **JEFFREY VOLLAT**  
P.E. No. 63930  
CIVIL ENG. STATE OF FL.



**CITY OF DORAL**  
**CANAL BANK RESTORATION**  
**PROGRAM - FISCAL YEAR 5**  
**(PHASE II)**

DATE: 06/2020	SCALE: AS SHOWN	CADD FILE: 30-33 DETAILS
DESIGN BY: J.V.	DRAWN BY: M.K.	CHECKED BY: C.O.

**DETAILS**



P:\Projects\173 City of Doral\0514\_Canal Bank Stabilization Program Management\01\_Year 5 Design\05\_Drawings\Year 5A - Phase II\44\_DETAILS\_YR-5.dwg Jun 11, 2020 - 3:55pm CORTEGA

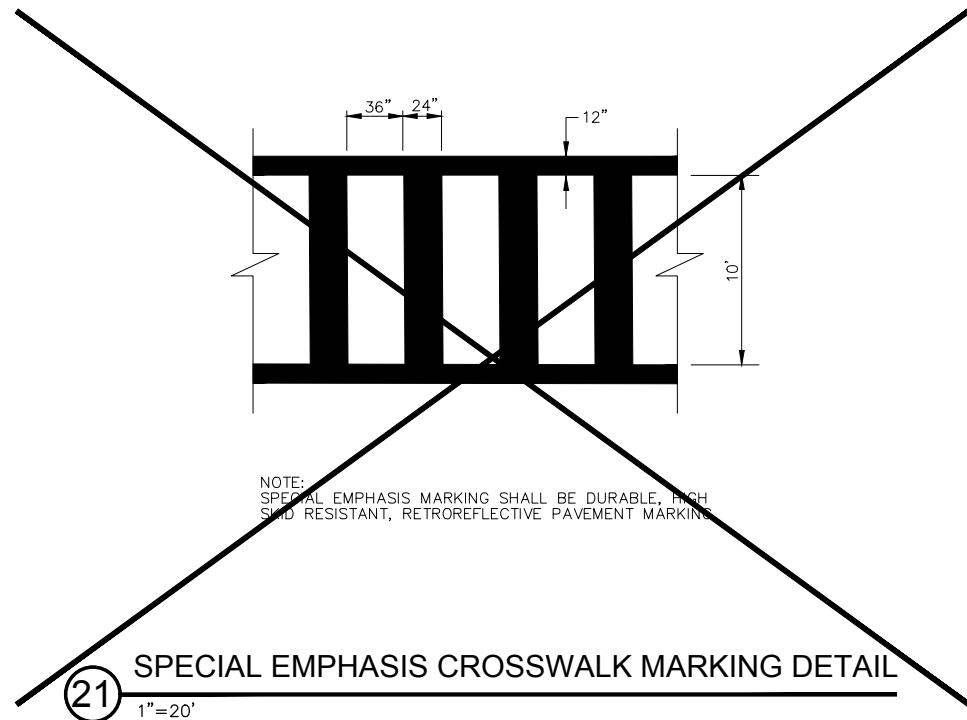

**21** SPECIAL EMPHASIS CROSSWALK MARKING DETAIL  
1"=20'

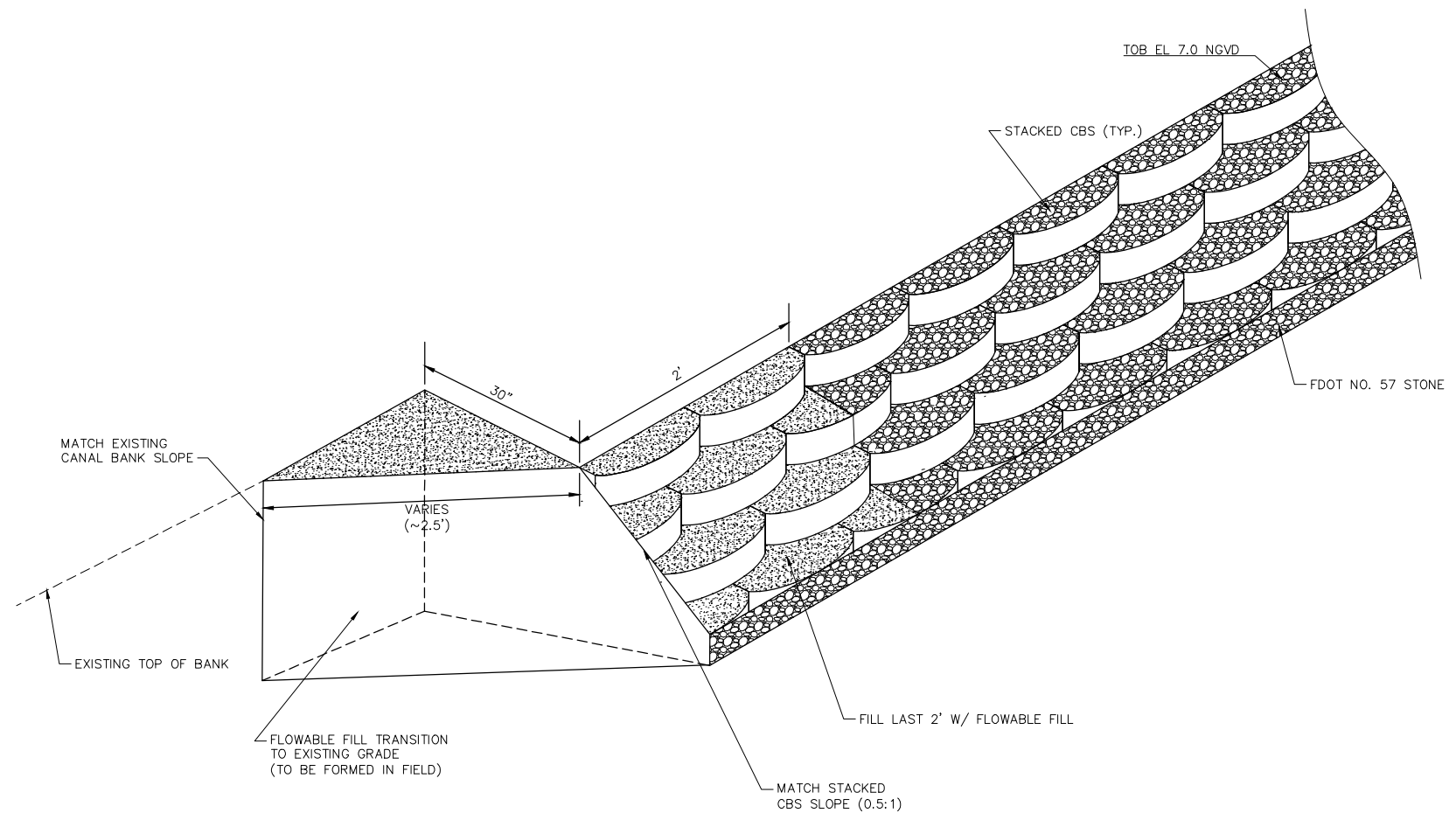

**22** STACKED CBS SPECIAL END TREATMENT  
N.T.S.

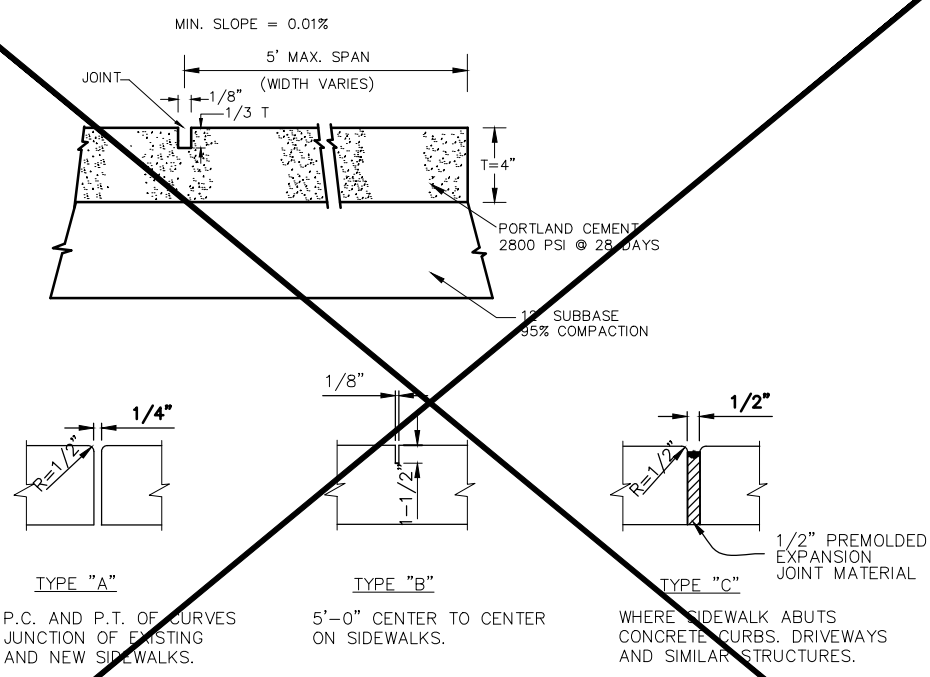

**23** CONCRETE SIDEWALK DETAIL  
N.T.S.

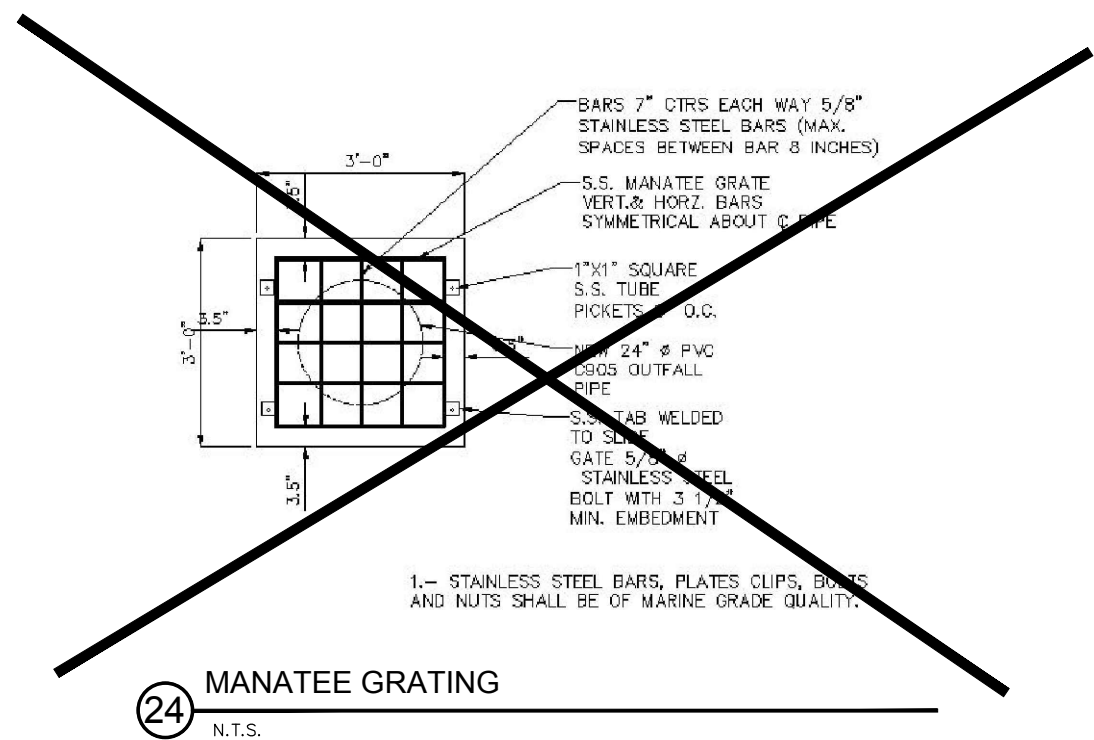

**24** MANATEE GRATING  
N.T.S.

**REVISIONS**

DATE	BY	DESCRIPTION	DATE	BY	DESCRIPTION

8550 N.W. 33RD STREET • SUITE 202  
DORAL, FLORIDA 33122  
PHONE (305) 551-4608 • FAX (305) 551-8977  
WWW.ADAENG.NET EB # 06003212

BY: **JEFFREY VOLLAT**  
P.E. No. 63930  
CIVIL ENG. STATE OF FL.



**CITY OF DORAL  
CANAL BANK RESTORATION  
PROGRAM - FISCAL YEAR 5  
(PHASE II)**

DATE: 06/2020  
SCALE: AS SHOWN  
CADD FILE: 10-22 PLAN  
DESIGN BY: J.V.  
DRAWN BY: M.K.  
CHECKED BY: C.O.

DETAILS

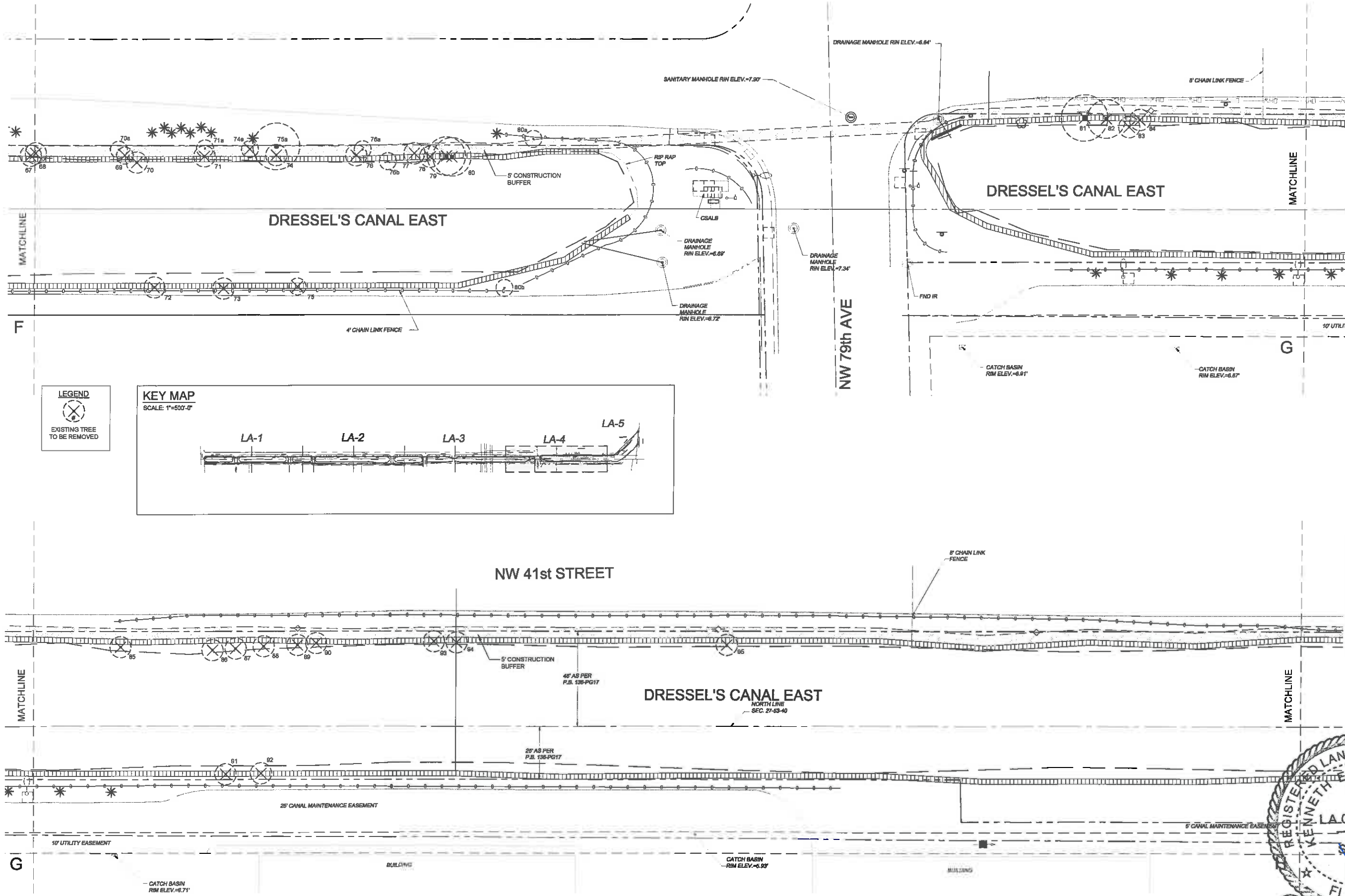

**LEGEND**  
 EXISTING TREE TO BE REMOVED

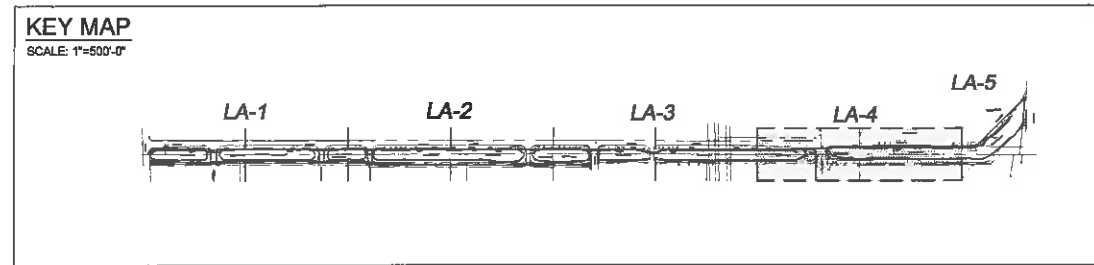

EXISTING TREE DISPOSITION PLAN  
 SCALE: 1"=20'-0"

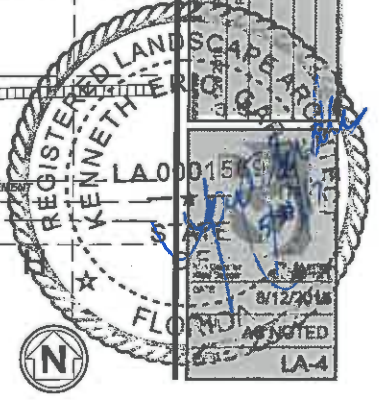

Doral, FL

LA-4

PEPSI MANUFACTURING  
COMPANY



NW 41st STREET

8' CHAIN LINK FENCE

8' CONSTRUCTION BUFFER

DRESSSEL'S CANAL EAST

25' CANAL MAINTENANCE EASEMENT

8' CHAIN LINK FENCE

MATCHLINE

**LEGEND**  
  
EXISTING TREE TO BE REMOVED

**KEY MAP**  
SCALE: 1"=500'-0"

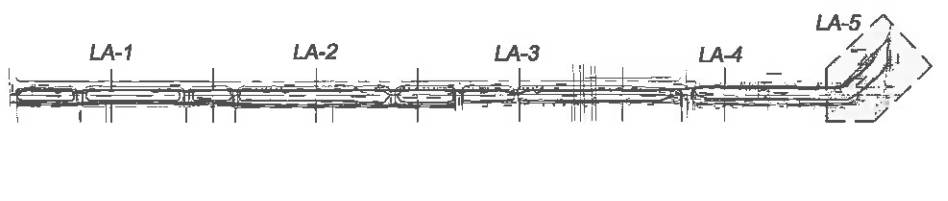

EXISTING TREE DISPOSITION LIST

KEY	BOTANICAL NAME	COMMON NAME	SIZE		REMAIN	REMOVE	TRANSPL.	MITIGATION
			HT. (ft.)	SPD. (ft.)				
1	Ficus aurea	Strangler Fig	28	30	18.6	X		
1a	Ficus aurea	Strangler Fig	28	36	36"		X	1923
2	Royaltone regia	Royal Palm	35	15	16		X	177
3	Royaltone regia	Royal Palm	40	18	17	X		177
3a	Royaltone regia	Royal Palm	40	18	17	X		
3b	Schefflera actinophylla	Schefflera	32	12	12.5		X	exempt by ordinance
3c	Sabal palmetto	Sabal Palm	12	10	10	X		
4	Psychopoma elegans	Spotted Palm	20	12	14		X	113
4a	Ficus nitida	Laurel Fig	35	45	28	X		
4b	Bursera simaruba	Gumbo Limbo	24	14	7	X		
5	Sabal palmetto	Sabal Palm	12	10	10		X	79
6	Ficus aurea	Strangler Fig	20	25	38		X	961
6a	Royaltone regia	Royal Palm	40	18	18	X		
6b	Psychopoma elegans	Spotted Palm	17	8	8	X		
7	Sabal palmetto	Sabal Palm	8	10	10		X	79
8	Sabal palmetto	Sabal Palm	12	10	10		X	79
9	Bursera simaruba	Gumbo Limbo	18	20	9		X	314
9a	Rogersia parviflora	Rogersia	20	38	11	X		
9b	Royaltone regia	Royal Palm	40	18	17	X		
10	Bacopa bacarum	Black Olive	20	25	9		X	491
11	Asclepias tuberosa	Asclepias	30	40	24		X	2512
12	Royaltone regia	Royal Palm	30	18	14		X	177
12a	Royaltone regia	Royal Palm	36	15	17	X		
12b	Royaltone regia	Royal Palm	40	18	21	X		
13	Schefflera actinophylla	Schefflera	30	18	10		X	exempt by ordinance
14	Rogersia parviflora	Rogersia	20	20	5		X	exempt by ordinance
14a	Royaltone regia	Royal Palm	40	18	15.5	X		
14b	Royaltone regia	Royal Palm	40	18	17	X		
14c	Royaltone regia	Royal Palm	38	20	18	X		
14d	Royaltone regia	Royal Palm	38	20	18	X		
14e	Royaltone regia	Royal Palm	38	12	14	X		
14f	Royaltone regia	Royal Palm	40	18	19	X		
14g	Schinus molle	Brazilian Pepper	14	22	17		X	
14h	Royaltone regia	Royal Palm	40	18	18	X		exempt by ordinance
14i	Sabal palmetto	Sabal Palm	16	10	10	X		
14j	Royaltone regia	Royal Palm	28	18	19	X		exempt by ordinance
14k	Royaltone regia	Royal Palm	38	18	16.5	X		
14l	Royaltone regia	Royal Palm	30	18	15	X		
15	Sabal palmetto	Sabal Palm	14	10	10	X		
15a	Sabal palmetto	Sabal Palm	14	10	10	X		
15b	Sabal palmetto	Sabal Palm	14	10	10	X		79
15c	Sabal palmetto	Sabal Palm	14	10	10	X		79
17	Sabal palmetto	Sabal Palm	20	10	10	X		79
18	Royaltone regia	Royal Palm	38	18	15	X		177
19	Psychopoma elegans	Spotted Palm	20	10	14	X		79
20	Ficus aurea	Strangler Fig	18	6	12	X		26
20a	Royaltone regia	Royal Palm	42	18	14	X		
21	Swietenia mahagoni	Mahogany	25	35	24	X		1923
21a	Swietenia mahagoni	Mahogany	32	40	24.5	X		
21b	Royaltone regia	Royal Palm	38	8	17	X		
22	Sabal palmetto	Sabal Palm	10	10	10	X		79
23	Sabal palmetto	Sabal Palm	10	10	10	X		79
23a	Royaltone regia	Royal Palm	30	14	18	X		
25	Swietenia mahagoni	Mahogany	25	35	17	X		962
25a	Royaltone regia	Royal Palm	32	18	16	X		
25b	Swietenia mahagoni	Mahogany	30	42	18	X		
25c	Royaltone regia	Royal Palm	40	18	19	X		
25d	Schefflera actinophylla	Schefflera	12	15	7.5	X		exempt by ordinance
26	Sabal palmetto	Sabal Palm	10	10	10	X		79
26a	Sabal palmetto	Sabal Palm	14	10	10	X		
26b	Bursera simaruba	Gumbo Limbo	24	28	11.5	X		
27	Coccoloba vitifera	Sawgrass	15	30	8		X	707
27a	Sabal palmetto	Sabal Palm	14	10	10	X		
27b	Swietenia mahagoni	Mahogany	30	28	18	X		
27c	Swietenia mahagoni	Mahogany	30	42	26	X		
28	Sabal palmetto	Sabal Palm	8	10	10	X		79
29	Sabal palmetto	Sabal Palm	8	10	10	X		79
29a	Swietenia mahagoni	Mahogany	38	45	28	X		
30	Sabal palmetto	Sabal Palm	5	10	10	X		79
30a	Sabal palmetto	Sabal Palm	18	10	10	X		
30b	Sabal palmetto	Sabal Palm	16	10	10	X		
30c	Swietenia mahagoni	Mahogany	48	40	19	X		
30d	Swietenia mahagoni	Mahogany	48	40	36.5	X		
30e	Swietenia mahagoni	Mahogany	25	30	12	X		
31	Sabal palmetto	Sabal Palm	6	10	10	X		79
31a	Sabal palmetto	Sabal Palm	14	10	10	X		
32	Sabal palmetto	Sabal Palm	7	10	10	X		79
33	Sabal palmetto	Sabal Palm	10	10	10	X		25
34	Sabal palmetto	Sabal Palm	10	7	10	X		35
35	Bursera simaruba	Gumbo Limbo	15	8	6	X		50
36	Bursera simaruba	Gumbo Limbo	10	8	4	X		60
37	Bursera simaruba	Gumbo Limbo	13	8	6	X		50
38	Sabal palmetto	Sabal Palm	10	10	10	X		79
39	Sabal palmetto	Sabal Palm	8	10	10	X		79
40	Sabal palmetto	Sabal Palm	7	10	10	X		79
41	Sabal palmetto	Sabal Palm	18	10	10	X		79
41a	Sabal palmetto	Sabal Palm	24	10	10	X		79
42	Ficus nitida	Laurel Fig	30	40	16	X		exempt by ordinance
42a	Ficus nitida	Laurel Fig	30	45	18	X		exempt by ordinance
42b	Ficus nitida	Laurel Fig	30	45	18	X		exempt by ordinance
42c	Ficus nitida	Laurel Fig	30	45	22	X		exempt by ordinance
43	Sabal palmetto	Sabal Palm	9	10	10	X		79

KEY	BOTANICAL NAME	COMMON NAME	SIZE	REMAIN	REMOVE	TRANSPL.	MITIGATION
43a	Swietenia mahagoni	Mahogany	44	58	31.5	X	
43b	Swietenia mahagoni	Mahogany	42	52	28.0	X	
43c	Swietenia mahagoni	Mahogany	18	14	6.5	X	
43d	Swietenia mahagoni	Mahogany	46	60	39	X	
43e	Swietenia mahagoni	Mahogany	48	28	27.6	X	
43f	Swietenia mahagoni	Mahogany	44	35	35	X	
44	Royaltone regia	Royal Palm	22	15	16	X	177
45	Casuarina spp.	Australian Pine	30	40	18	X	exempt by ordinance
46	Sabal palmetto	Sabal Palm	8	15	10	X	177
46a	Royaltone regia	Royal Palm	24	18	16	X	
46b	Baccharis halimifolia	Hong Kong Orchid (poor)	18	26	22	X	1091
46c	Swietenia mahagoni	Mahogany	26	26	11.6	X	
47	Callitriche viminalis	Red Sotolobush	10	10	11	X	79
47a	Swietenia mahagoni	Mahogany	44	58	38.5	X	
47b	Swietenia mahagoni	Mahogany	36	50	21	X	
47c	Sabal palmetto	Sabal Palm	10	10	9	X	
47d	Swietenia mahagoni	Mahogany	40	62	33	X	
47e	Swietenia mahagoni	Mahogany	48	64	33.5	X	
47f	Swietenia mahagoni	Mahogany	38	48	34.5	X	
48	Callitriche viminalis	Red Sotolobush	15	12	12	X	115
48a	Callitriche viminalis	Red Sotolobush (Dead)	0	0	0	X	
48b	Sabal palmetto	Sabal Palm	16	10	10	X	
49	Callitriche viminalis	Red Sotolobush	18	20	18	X	82e
49a	Sabal palmetto	Sabal Palm	16	10	10	X	
49b	Sabal palmetto	Sabal Palm	17	10	10	X	
49c	Sabal palmetto	Sabal Palm	16	10	10	X	
49d	Sabal palmetto	Sabal Palm	18	10	10	X	
50	Schefflera actinophylla	Schefflera	18	18	6	X	exempt by ordinance
50a	Sabal palmetto	Sabal Palm	18	10	10	X	
50b	Sabal palmetto	Sabal Palm	15	10	10	X	
50c	Sabal palmetto	Sabal Palm	18	10	10	X	
50d	Sabal palmetto	Sabal Palm	18	10	10	X	
50e	Sabal palmetto	Sabal Palm	18	10	10	X	
51	Schefflera actinophylla	Schefflera	22	15	8	X	exempt by ordinance
52	Sabal palmetto	Sabal Palm	18	10	10	X	79
53	Sabal palmetto	Sabal Palm	20	10	10	X	79
54	Schefflera actinophylla	Schefflera	18	15	6	X	exempt by ordinance
55	Sabal palmetto	Sabal Palm	10	10	10	X	79
56	Tabebuia heterophylla	Pink Trumpet Tree	22	12	8	X	113
57	Sabal palmetto	Sabal Palm	3	10	10	X	79
57a	Sabal palmetto	Sabal Palm	16	10	10	X	
57b	Sabal palmetto	Sabal Palm	18	10	10	X	
58	Sabal palmetto	Sabal Palm	2	10	10	X	79
59	Sabal palmetto	Sabal Palm	2	10	10	X	79
60	Sabal palmetto	Sabal Palm	2	10	10	X	79
61	Sabal palmetto	Sabal Palm	2	10	10	X	79
62	Sabal palmetto	Sabal Palm	2	10	10	X	79
63	Sabal palmetto	Sabal Palm	2	10	10	X	79
64	Sabal palmetto	Sabal Palm	2	10	10	X	79
65	Sabal palmetto	Sabal Palm	8	10	10	X	79
66	Schefflera actinophylla	Schefflera	11	10	3	X	exempt by ordinance
66a	Sabal palmetto	Sabal Palm	14	10	10	X	
67	Sabal palmetto	Sabal Palm	18	10	10	X	79
67a	Schefflera actinophylla	Schefflera	24	9	8	X	exempt by ordinance
67b	Sabal palmetto	Sabal Palm	24	10	10	X	
67c	Sabal palmetto	Sabal Palm	16	10	10	X	
67d	Sabal palmetto	Sabal Palm	18	10	10	X	
68	Sabal palmetto	Sabal Palm	10	10	10	X	79
69	Schefflera actinophylla	Schefflera	15	8	4	X	exempt by ordinance
70	Sabal palmetto	Sabal Palm	12	10	10	X	79
71	Sabal palmetto	Sabal Palm	7	10	10	X	
71a	Sabal palmetto	Sabal Palm	4	10	10	X	79
71b	Sabal palmetto	Sabal Palm	8	10	10	X	
72	Sabal palmetto	Sabal Palm	3	10	10	X	79
73	Sabal palmetto	Sabal Palm	3	10	10	X	79
74	Sabal palmetto	Sabal Palm	18	10	10	X	79
75	Ficus aurea	Strangler Fig	13	8	4	X	50
76	Ficus aurea	Strangler Fig	28	22	18	X	
76a	Sabal palmetto	Sabal Palm	3	10	10	X	79
76b	Sabal palmetto	Sabal Palm	10	10	10	X	
77	Sabal palmetto	Sabal Palm	8	10	10	X	79
78	Sabal palmetto	Sabal Palm	5	10	10	X	79
79	Tabebuia heterophylla	Pink Trumpet Tree	23	18	12	X	254
80	Tabebuia heterophylla	Pink Trumpet Tree	23	18	11	X	254
80a	Sabal palmetto	Sabal Palm	10	10	10	X	
80b	Sabal palmetto	Sabal Palm	12	10	10	X	
81	Swietenia mahagoni	Mahogany	24	22	10	X	360
82	Bursera simaruba	Gumbo Limbo	20	18	8	X	254
83	Sabal palmetto	Sabal Palm	4	10	10	X	79
84	Sabal palmetto	Sabal Palm	8	10	10	X	79
85	Sabal palmetto	Sabal Palm	8	10	10	X	79
86	Sabal palmetto	Sabal Palm	4	10	10	X	79
87	Sabal palmetto	Sabal Palm	4	10	10	X	79
88	Sabal palmetto	Sabal Palm	8	18	10	X	79
89	Sabal palmetto	Sabal Palm	4	10	10	X	79
90	Sabal palmetto	Sabal Palm	5	10	10	X	79
91	Sabal palmetto	Sabal Palm	3	10	10	X	79
92	Sabal palmetto	Sabal Palm	5	10	10	X	79
93	Sabal palmetto	Sabal Palm	4	10	10	X	

**LANDSCAPE SPECIFICATIONS  
PART 1 - GENERAL**

**1.1 SCOPE**  
A. Contractor shall provide all labor, materials, equipment, supervision, and related work necessary to complete the landscape work in accordance with the intent of the landscape plans, schedules and these specifications. The extent of work is shown on the drawings which are a part of this document.

**1.2 CONTRACTOR QUALIFICATIONS**  
A. Landscape installation work to be performed by a Contractor Certified by the Florida Nurserymen, Growers and Landscape Association (FNLGA) as a Certified Landscape Contractor. Any planting to be supervised by an Arborist, certified by the International Society of Arboriculture (ISA) and licensed in Miami-Dade County.

**1.3 INVESTIGATION OF UTILITIES**  
A. Prior to beginning work, the Contractor shall be responsible to locate existing underground utilities. Check with all utility companies and Sunshine State, call (811).

**1.4 SUBSTITUTIONS**  
A. Only materials specified will be accepted, unless approved in writing by the Landscape Architect in advance.

**1.5 PLANT SIZES**  
A. All plant sizes shall equal or exceed the minimum sizes as specified in the plant list. When plant sizes are specified as a range of sizes, installed materials shall average the mean of the range specified. Plants shall be measured following pruning, with branches in normal position. All necessary pruning shall be done at the time of planting.

**1.6 PLANT QUALITY**  
A. All plant material shall be equal to or better than Florida No. 1 as classified by "Grades and Standards for Nursery Plants" by the Division of Plant Industry, Florida Department of Agriculture. They shall have a growth habit that is normal for the species, healthy, vigorous, free from insects, disease and injury.  
B. The Owner or Landscape Architect reserves the right to refuse any plant material which does not conform to the intent of the written specifications or design.

**C. CIRCLING ROOTS FOUND ON CONTAINER-GROWN MATERIAL WILL NOT BE ACCEPTED UNLESS REMEDIAL ROOT PRUNING, APPROVED BY THE LANDSCAPE ARCHITECT IS DONE BEFORE PLANTING.**

**1.7 PLANT QUANTITY**  
A. The plant quantities shown on the plant list are to be used only as an aid to bidders. In the case of discrepancy between the plant list and the plan, the quantity on the plan shall override the plant list.

**1.8 UNIT PRICES**  
A. The successful bidder shall furnish to the Owner and the Landscape Architect, a unit price breakdown for all materials. The Owner may, at his discretion, add to or delete from the materials utilizing the unit price breakdown submitted to and accepted by the Owner.

**1.9 SUBMITTALS**  
A. Fertilizer: The Contractor shall submit to the Owner and Landscape Architect documentation that all fertilizer used for the project is of the analysis specified and placed at the rates specified in section 2.2 FERTILIZER.

**B. Planting soil:** The Contractor shall submit a sample of the planting soil (approximately 1 cu. ft.) for approval by the Landscape Architect prior to delivery to the site.

**1.10 CLEANUP & MAINTENANCE OF TRAFFIC**  
A. Follow procedures in FDOT Index 600 for maintenance of traffic during construction.  
B. At the end of each work day, the Contractor shall remove debris and shall barricade the unfilled holes in a manner appropriate in the path of pedestrians and motorists.

**C. Upon completion of the work or any major portion of the work or as directed by the Landscape Architect, all debris and surplus material from the work shall be removed from the job site.**

**1.11 MAINTENANCE PRIOR TO ACCEPTANCE**  
A. The Contractor is responsible to maintain the plantings until they are accepted under the provisions of 1.12 "ACCEPTANCE OF INSTALLATION".

1. Plants: Begin maintenance immediately following the final plant installation operation for each plant and continue until all plant installation is complete and accepted. Maintenance shall include watering all plants, weeding, mulching, pest and disease control, lightening and repairing of gaps, repair of brows, removal of dead growth, rewatering of plants in proper grade or up-right position, restoration of plant sources, filter pick-up in plant beds and other necessary operations to ensure specified minimum grade of Florida No. 1.

2. Turf Areas: Begin maintenance of turf immediately following the placement of sod and continue until sod installation is complete and accepted. Maintenance shall include but not be limited to, watering, leveling, mowing, weed and pest control, fungus and disease control and other necessary operations as determined by the Landscape Architect and good nursery practice.

3. Re-watering or straightening trees and palms:  
The Contractor shall re-water and/or straighten trees and palms as required at no additional cost to the Owner unless caused by sustained winds of 75 mph or more. Then, the costs of the operation may be charged to the owner. Re-water trees within 48 hours.

**1.12 ACCEPTANCE OF INSTALLATION**  
A. Inspection: Inspection of the work to determine completion of contract work, exclusive of the possible replacement of plants and turf will be made by the Landscape Architect at the completion of the maintenance period. Written notices requesting such an inspection and submitted by the Contractor at least ten (10) days prior to the anticipated date.

**1.13 GUARANTEE**  
A. Guarantee all plants for a period of one year (100%). Guarantee shall commence from the date of written acceptance. Plant material which on the site and scheduled to be relocated is not covered by the guarantee except in the case of Contractor's negligence or work that has been done in an unworkman-like manner. The Contractor is not responsible for loss due to acts of god, (i.e.) sustained winds of 75 mph or more, floods, frost, lightning, vandalism or theft.

**1.14 REPLACEMENT**  
A. Replacement shall be made during the guarantee period as directed by the Landscape Architect within ten (10) days from time of notification. For all replacement plants installed, the guarantee period shall extend for an additional forty-five (45) days beyond the original guarantee period. The Contractor shall be responsible to provide water to the replacement plants in sufficient quantity to aid in their establishment. At the end of the guarantee period, inspection will be made by the Landscape Architect, upon written notice requesting such inspection and submitted by the Contractor at least five (5) days before the anticipated date. Replacement plants must meet the requirements of Florida No. 1 at time of inspection. Remove from the site all plants that are dead or in a state of unsatisfactory growth, as determined by the Landscape Architect. Replace trees and any plants missing due to the Contractor's negligence as soon as conditions permit.

1. Materials and Operations: All replacement plants shall be of the same kind and size as indicated on the plant list. The Contractor shall supply and plant the plants as specified under planting operations.

2. Cost of Replacement: A sum sufficient to cover the estimated cost of possible replacements, including material and labor will be retained by the Owner and paid to the Contractor after all replacements have been satisfactorily made and approved by the Landscape Architect.

**PART 2 - MATERIALS**  
**2.1 PLANTING SOIL**  
A. Planting soil for trees, shrubs and ground covers shall be of the composition noted on the plans, measured by volume.  
B. Soil for Sodded Areas: shall be coarse loam sand.

**2.2 FERTILIZER**  
A. Fertilizer for trees, palms, shrubs, and groundcovers shall be as follows: LE800 Palm Special 15-5-13 or equal, Sulfol coated with iron and zinc and maximum of 2% chlorine, or brand with equal analysis. The fertilizer shall be uniform in composition, dry and free flowing and shall be delivered to the site in the original unopened containers, bearing the manufacturer's guaranteed analysis. Fertilizer for sod and seeded areas shall be 8-8-8, 50% organically derived nitrogen, or equal.

**2.3 WATER**  
A. The Contractor shall provide potable water on site, available from the start of planting. The Contractor is responsible to ascertain the location and accessibility of the water source. The Contractor is responsible to provide the means of distribution (i.e. water truck, hoses, etc.) for distribution of water to the planting areas.

**2.4 MULCH**  
A. Mulch shall be shredded Melaleuca mulch (Fimbricula) as manufactured by Forestry Resources, Inc., or equal.  
**2.5 ROOT BARRIER MATERIAL**  
A. When specified in the plans, root barrier material shall be Biobarrier (10.5 inch width) Reemay or approved equal.

B. Install per details in the plans.  
**PART 3 - INSTALLATION PROCEDURES**  
**3.1 LAYOUT**  
A. Verify location of all underground utilities and obstructions prior to excavation.

**3.2 HERBICIDE TREATMENT**  
A. In all areas indicated with weed and/or grass growth, a systemic herbicide, such as Roundup, shall be applied per manufacturer's rates. When it has been established where work will be done, the systemic herbicide shall be applied in accordance with manufacturer's labeling to kill all noxious growth. Contractor shall schedule his work to allow more than one application to obtain at least 80% kill of undesirable growth. If necessary, Contractor shall conduct a test to establish suitability of product and applicator to be used on this project, prior to execution of the full application.

**3.3 PLANT PIT EXCAVATION AND BACKFILLING**  
A. Trees: See the Planting and Bracing Details and notes.  
B. All planting holes shall be hand dug where machine dug holes may adversely affect utilities or improvements.

C. Shrubs and Groundcover: Shrubs and groundcover shall be planted in a soil bed as described in the notes and details. Space shrubs and provide setback from curb and pavement as shown in the plans.  
D. Watering of field-grown plants: Thoroughly puddle in water to remove any air pockets in the plant hole.

**3.4 WATERING**  
A. The Contractor is responsible to provide the water for all new plants and transplants and means of distribution (i.e. hand watering or water truck) during the maintenance period and extending into the period after acceptance until the full schedule as stated below is complete. Water for trees and other large field-grown plants shall be supplemented by hand or water truck, in addition to the irrigation system, if one is provided. Contractor can adjust watering schedule during heavy rain season upon approval of the Landscape Architect.

**AMOUNT OF WATER PER APPLICATION**  
For trees up to 5 inch caliper - 5 gallons  
From 6 to 8 inch caliper - 25 gallons  
8 inch and up caliper - 50 gallons

**FREQUENCY OF WATER**  
Daily for the first week  
3 times per week for weeks 2 - 5  
2 times per week for weeks 6 - 8  
1 time per week for weeks 9 - 12

B. Water shrubs, sod and groundcover a minimum of once daily for a week or until an irrigation system is fully operational. If no irrigation system is to be installed, the Contractor shall be responsible for watering the shrubs, sod, and groundcover for the time specified above, after installation of each section of the planting installed.

**3.5 FERTILIZING**  
A. Add fertilizer on top of the surface of shrubs beds and trees and palms root balls two (2) months after installation. Fertilize sod within two (2) days after installing after planting of each segment of the job. Fertilizer shall be applied after soil has been well mulched. Fertilizer shall be washed off of plant leaves and stems immediately after application. Apply at the following rates:  
1. Trees and Large Shrubs: One (1) pound per inch of trunk diameter, spread evenly over the root ball area.  
2. Shrubs: One half (1/2) handful per shrub, spread evenly over the root ball area.  
3. Groundcover: Twelve (12) pounds per 100 sq. ft. of bed area.  
4. Sod: Twelve (12) pounds per 1,000 sq. ft. Wash fertilizer off blades immediately after spreading.

**3.6 MULCHING**  
A. Spread mulch two (2) inches thick uniformly over the entire surface of shrubs and groundcover beds, depth measured after settling, unless otherwise specified in the plans. Provide 36" diameter bed of mulch, measured from outer edge of the trunk, for all trees and palms planted in sod areas. Keep mulch away from contact with the trunk. Create a 6" high ring of mulch at the outer edge of tree and palm limbs.

**3.7 GUYING AND BRACING**  
A. See the details bound herewith or made part of the plans.

**3.8 ROOFCING**  
A. Provide a blanket of lawn sand as described in the notes in these plans. Prior to planting, remove stones, sticks, etc. from the sub-soil surface. Excavate existing non-conforming soil as required so that the finish grade of sod is flush with adjacent pavement or top of curb as well as adjacent grade in the case of sod patching.

B. Place sod on moistened soil, with edges tightly butted, in staggered rows at right angles to slopes. The sod shall be rolled with a 500 pound hand roller immediately after placing.  
C. Keep edges of sod bed a minimum of 18" away from groundcover beds and 24" away from edges of shrub beds and 36" from trees, measured from the edge of plant or tree trunk.

D. Sod shall be watered immediately after installation to uniformly wet the soil to at least two inches below the bottom of sod strips.  
E. Apply fertilizer to the sod as specified in Section 3.5.  
F. Excavate and remove excess soil to top of sod and flush with top of curb or adjacent pavement, or adjacent existing sod.

**PLANT BED PREPARATION NOTES**

1. In all areas where new sod and shrub and groundcover masses are to be planted, kill all existing weeds by treating with Roundup prior to beginning soil preparation.  
2. In all shrub and groundcover beds, prepare soil as described for either condition, over the entire area to be planted:

**Condition A:**  
If any compacted sand, loam or silt or rocky soil is encountered, remove compacted material entirely to allow an 18" depth of planting soil. Backfill the entire area of the shrub and groundcover beds with 18" planting soil (as specified in Plans) to within 2 inches of the adjacent pavement or top of curb. Remove all debris and rocks and pebbles larger than 1 inch in size and level the grade before planting.

**Condition B:**  
Where no compacted soil is encountered, thoroughly mix 6 inches of planting soil into the existing soil to a depth of 18 inches. If required, excavate and remove the existing soil to lower the grade, so that the prepared mix is finished to a minimum of 2 inches below top of curb or adjacent walkway. Remove all debris and rocks and pebbles larger than 1 inch in size and level the grade before planting.

**For all sod areas:** spread a 2" deep layer of lawn sand prior to sodding. Remove all debris and rocks and pebbles larger than 1 inch in size and level the grade before sodding. Remove, if required, existing soil so that top of sod is flush with and adjacent top of curb or pavement.

**SPACING OF PLANTS (SEE PLANT SPACING DETAIL)**  
1. Plants shall be planted sufficiently away from edges of pavements or curbs, to allow for growth toward the edges of the bed.

**PROTECTION OF PLANTS**  
1. The Contractor shall be responsible to protect existing trees and shrubs in and existing to the area of work. Erect barriers as necessary to keep equipment and materials away from existing trees and shrubs. DO NOT PILE SOIL OR DEBRIS AGAINST TREE TRUNKS OR DEPOSIT NOXIOUS BUILDING SUPPLIES OR CHEMICALS WITHIN THE DRIP LINE.



**TREE PROTECTION DETAIL**

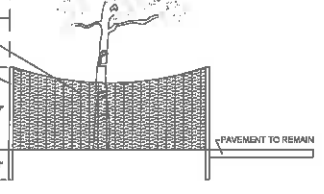

**ROOT BARRIER INSTALLATION DETAIL**



**BATTEN DETAIL B**

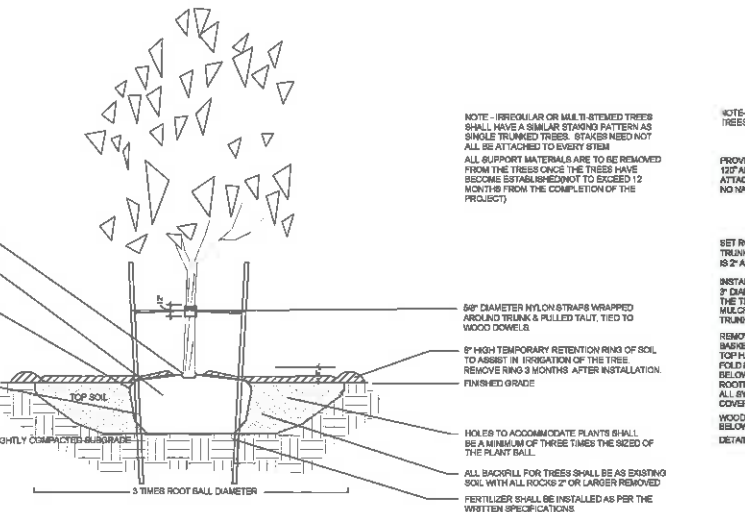

**PLANTING & BRACING DETAIL UNDER 3 1/2" CALIPER**

N.T.S.

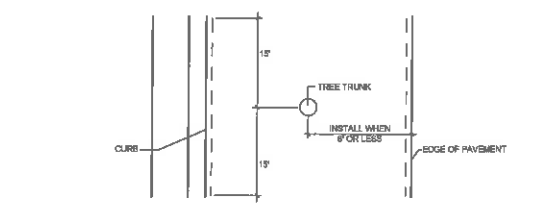

**PLANTING & BRACING DETAIL OVER 3 1/2" CALIPER**

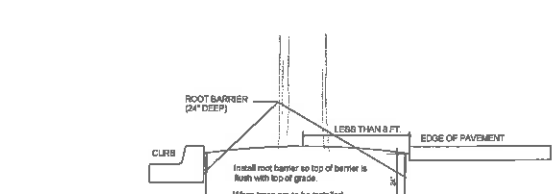

**BATTEN DETAIL A**

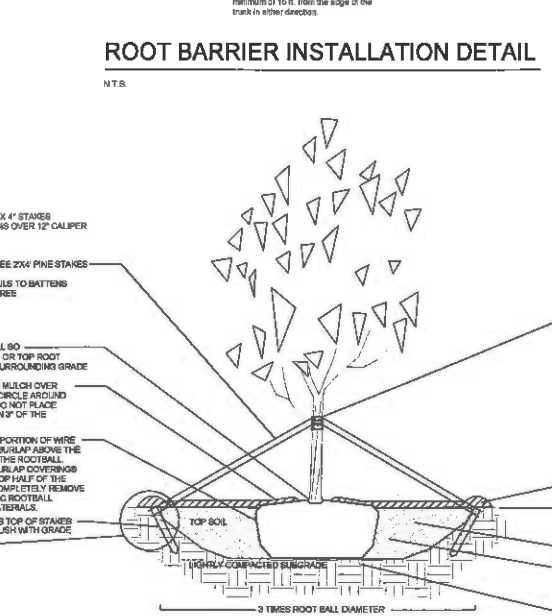

**PLANTING & BRACING DETAIL OVER 3 1/2" CALIPER**

N.T.S.



**DORAL CANAL BANK STABILIZATION - YEAR 5**  
Doral, FL  
PLANTING NOTES, SPECIFICATIONS, AND DETAILS

