

CITY OF DORAL

FACADE IMPROVEMENT GRANT AGREEMENT

THIS AGREEMENT is made and entered into this 4 day of October, 2018 by and between the City of Doral, Florida, ("City") and **Alfe Holdings LLC**, owner of a property located at **3400 NW 78th Avenue, Doral, FL 33122**, whose Federal I.D. No. is **47-3804463** ("Recipient").

RECITALS

WHEREAS, the City of Doral is desirous of encouraging activities which contribute to the enhancement of redevelopment activities in Doral, Florida; and

WHEREAS, the Doral Façade Improvement Grant Program provides financial assistance to businesses, home owner associations and property owners in Doral in order to stimulate private sector investment, beautification, economic growth and job creation in the City by improving the appearance of the buildings within City boundaries; and

WHEREAS, the program will provide financial assistance by contributing up to 50% of the costs, in an amount not to exceed \$10,000 per project, associated with façade and beautification projects for properties throughout the City limits; and

WHEREAS, pursuant to the FACADE IMPROVEMENT GRANT PROGRAM, **Fernando Jimenez**, as a duly authorized representative of Recipient, has applied for a Grant to assist it in making exterior property improvements to the property located at **3400 NW 78th Avenue, Doral, FL 33122**; and

WHEREAS, after reviewing the application submitted by Recipient, the City has found and determined that it would be beneficial to its economic development and beautification efforts to support Recipient's improvement project through a grant of funds upon the terms and conditions hereinafter described; and

NOW, THEREFORE, for the mutual considerations described herein and other good and valuable consideration, the parties agree as follows:

I) CITY Obligations and Responsibilities:

- (A) Upon Recipient completing the comprehensive exterior improvements acceptable to the City Manager and after construction is completed and upon receipt of all documentation relating to the projects improvement costs, the City shall reimburse Recipient for 50 % of the construction cost up to a maximum grant of **\$10,000.00**. In the event that Recipient fails to complete the comprehensive exterior improvements by the completion date, City shall not be liable for reimbursement for any construction costs unless the City Manager agrees in writing.
- (B) The CITY shall not be liable for payments for services beyond the scope of the City authorized improvements, nor shall the City be liable for improvements which are made after the exterior property improvement project is completed or after the City has authorized reimbursement to the Recipient.
- (C) The City shall not be a party to nor is it liable for any contractual payments to any contractors, architects or other third parties. Payments to any contractors, architects or other parties are the sole responsibility of the Recipient.

II) Recipient Obligations and Responsibilities:

- (A) Recipient agrees to accept grant funds in an amount not to exceed **\$10,000.00**. Such grant funds shall be done on a reimbursement basis and shall only be for 50% of the construction cost up to a maximum grant amount of \$10,000.00; and
- (B) Recipient acknowledges and agrees that the grant funds are to be used solely for property improvements approved by the City on the property located at: **3400 NW 78th Avenue, Doral, FL 33122**; and
- (C) Recipient acknowledges that it is the owner of the subject property, or if the Recipient is not the owner, it has received the owner's written consent to improve the subject property (shown in Exhibit "A" which is attached hereto and incorporated by reference) and as such it is authorized to contract for exterior property improvements; and
- (D) Recipient shall submit grant application within grant cycle and before submission deadline. A final design sketch of the exterior property improvements along with the selected contractor's bid for the improvements will be included as part of the Façade Improvement Grant Application Packet (which is attached hereto within Exhibit "B" and is incorporated herein by reference.) At least two additional comparable estimates by licensed contractors will also be required as part of the Grant Application Packet. All general exterior property improvements shall be consistent with all applicable Federal, State and City of Doral codes and design regulations; and
- (E) Recipient agrees that all exterior property improvements as set forth in Exhibit "B" shall be completed by 10/04/19 (the completion date) and no grant fund reimbursement payments shall be made prior to completion; and
- (F) Recipient shall comply with all applicable federal, state, county and municipal laws, ordinances, codes and regulations; and

- (G) Recipient shall maintain books, records, and documents in accordance with generally accepted accounting procedures and practices to maintain adequate internal controls which, relating to façade improvements, sufficiently and properly reflect all expenditures of funds provided by the City under this Agreement; and
- (H) Recipient shall make all books pertaining to the business and exterior property improvements project available to the City for inspection, review or audit purposes at all reasonable times upon demand the term of this Agreement and for three (3) years thereafter; and
- (I) The Recipient shall submit to the City not more than sixty (60) days after the exterior property improvement project is completed, all supporting documentation, including but not limited to paid receipts, two color photographs of the completed exterior property improvements and documentation relating to the construction costs expended for the exterior property improvements project on the subject property; and
- (J) The Recipient and or the Recipient's contractor(s) shall carry worker's compensation insurance to cover all workers involved in the project. Recipient shall maintain, at its own expense, General Liability Insurance covering the subject property and the resultant uses thereof in the amount of \$1,000,000.00 and will maintain property damage coverage for a minimum of \$100,000.00 the premium of which shall be paid prior to execution of this Agreement. Said insurance shall name the City as an additional insured; and shall provide that the City will receive notice of any cancellation or change in coverage. Recipient shall furnish City with certificates of Insurance. Any lapse of this coverage during this period of the Agreement shall be grounds for termination of the Agreement by the City.

(III) Representations

As a material consideration in granting the funds which are the subject of this agreement, the City has relied upon the following representatives of the Recipient:

1. Recipient, or any of its officers, directors, or employees has not been convicted of any felony or crime involving dishonesty, fraud, misrepresentation or moral turpitude.
2. To the best knowledge of the Recipient, there is no action, investigation or proceeding pending against the Recipient or any of its officers, directors or employees involving dishonesty, fraud, misrepresentation, moral turpitude or like matters, nor is there any factual basis which is likely to give rise to such an action, investigation or proceeding.
3. The Recipient is a duly authorized representative of the business and is authorized to execute this Agreement.
4. The Recipient shall comply with all applicable laws and procedures in connection with the expenditure of funds including but not limited to obtaining all necessary permits and licenses.

(IV) Term of Agreement

This Agreement shall commence upon execution and shall expire sixty (60) days after the Completion Date. In the event that the Recipient fails to complete the project within one (1) year from the date of execution of this

Agreement, City reserves the right to terminate this Agreement upon twenty-four (24) hours notice to Recipient.

(V) Designated Representatives

The names and addresses of the Designated Representatives of the parties in connection with this Agreement are as follows:

AS TO AGENCY: **City Manager**
City of Doral, FL
8401 NW 53rd Terrace
Doral, FL 33166

WITH A COPY TO: **General Counsel**
City of Doral, FL
8401 NW 53rd Terrace
Doral, FL 33166

AS TO RECIPIENT: **Alfe Holdings LLC**
3400 NW 78th Avenue,
Doral, FL 33122

WITH A COPY TO: _____

- (A) Recipient acknowledges that the City is not affiliated with or responsible for Recipient's activities hereunder or otherwise. Further, Recipient hereby indemnifies and holds harmless the City for any actions, suits, or proceedings arising out of the subject matter of this Agreement. Such obligation to indemnify and hold harmless shall continue notwithstanding any negligence or comparative negligence on the part of the City relating to such loss or damage and shall include all costs, expenses and liabilities incurred by the City in connection with any such claim, suit, action proceeding brought thereon and any order, judgment or decree which may be entered in any such action or proceeding or as a result thereof.
- (B) Recipient agrees that nothing herein contained is intended or should be construed as in any way creating or establishing the relationship of partners or joint ventures between the City and the Recipient as an agent, representative or employee of the City for any purpose or in any manner whatsoever, and that it shall not represent to any third parties that such is the case.
- (C) Recipient may not assign any rights under this Agreement without the prior written consent of the City, which may be withheld in its sole discretion.
- (D) The name and address of the official payee to whom payments hereunder will be made is:

Alfe Holdings LLC, 3400 NW 78th Avenue, Doral, FL 33122

- (E) This Agreement shall be governed by the laws of the State of Florida. Any and all legal action necessary to enforce this Agreement will be heard in Miami-Dade County, Florida. No remedy herein conferred upon any part is intended to be in addition to every other remedy given hereunder or now or hereafter existing at law or in equity or by statute or otherwise. No single or partial exercise by any part of any right, power or remedy hereunder shall preclude any other of further exercise thereof.
- (F) This Agreement may only be amended or modified by an instrument in writing signed by both parties.
- (G) The Recipient acknowledges and agrees that the City may in its sole discretion discontinue this program at any time. At all other times, either party can cancel this agreement by thirty-(30) days written notice to the other. In the event that Recipient cancels this Agreement, the City shall not be liable to any contractor (s) or subcontractor (s) with relation to any work performed pursuant to the contract between Recipient and the Contractor(s) or subcontractor(s).
- (H) As a condition of receiving funds through the Façade Improvement Program, property owners must agree to keep the façade improvements well maintained, and to refrain from substantial modification of same, for a period of one (1) year. Removal, substantial alteration, or failure to maintain the façade improvements with the specified time frame shall be cause for the City to demand reimbursement of granted funds. Upon demand from the City, the applicant's failure to repair and/or replace the improvements or to reimburse the granted funds may cause the City to place a lien on the property for the amount of granted funds and administrative fees. The property owner further agrees to execute, as a condition to the award, a covenant or other instrument in a form prescribed by the City which will be recorded in the Public Records as an encumbrance upon the property for one (1) year from the project completion date.

FACADE IMPROVEMENT GRANT PROGRAM AGREEMENT (ALFE HOLDINGS LLC)

ATTEST:

DORAL, FLORIDA



CONNIE DIAZ, CMC
CITY CLERK



EDWARD ROJAS
CITY MANAGER

Approved as to Form and Legality for
the Use and Reliance of the City of Doral,
Florida, only.

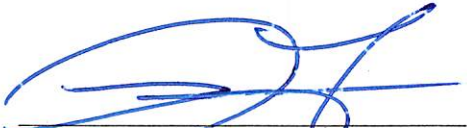

Wis Figueredo
GENERAL COUNSEL

AS TO RECIPIENT

ATTEST:

Alfe Holdings LLC

Maria Jacome

CORPORATE SECRETARY

By: 
Signature

Print Name: FERNANDO JIMENEZ

Title: MGR ALFE HOLDINGS LLC

E: Permit expeditorsmg@gmail.com
(786) 252-3770



17 AUG '18 PM 2:06

Applications Forms
Doral Façade Improvement Grant Program

Date 8/14/18

Name and Type of Business

ALFE HOLDINGS LLC dba KER ART Space

Location of Business
(Street address, name of building if applicable)

3400 NW 78 Ave
Doral FL 33122

Name/Address of Property Owner

3281 NW 78 Ave
Miami, FL 33122

Property Owner Phone

305-477-0096 x1006

Property Owner Mobile Phone

305-301-1508



Applicant's Mailing Address

3281 NW 78 Ave
Miami FL 33122

Email Address

Firmenet@KERTILES.com
PermitExpeditor@gmail.com

Property Folio # (s)

35-3027-007-0011

Permit #:

*Total Cost of Project \$ 85,000.

(attach itemized breakdown)

*Requested Grant Amount \$ 10k



General description of proposed improvement:

- Façade
- Siding
- Walls/Fencing/Railings
- ADA improvements
- Pedestrian amenities
- Windows/Doors
- Awnings/Canopies
- Lighting
- Painting
- Signage
- Detached monument signs
- Sidewalks/Surface Parking
- Landscape
- Other

Other details: Attach sheet if needed.

APPLICATION MUST BE ACCOMPANIED BY THREE (3) BONA FIDE BIDS FROM LICENSED CONTRACTORS FOR THE WORK TO BE COMPLETED UNDER THIS PROGRAM.

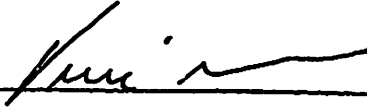
Signature of Property Owner 

Print Name of Property Owner Fernando Jimenez

Date 8.14.18



Work

Please provide a brief, general description of the work to be performed, materials to be used, color and material samples (if applicable).

☉ Exterior Walls (Includes façade (if applicable) structural, decorative and non-functional elements)

- *Decorative clip on panels on facade*

- Siding

- Windows/Doors

- Awnings/Canopies

- Walls/Fencing

- Lighting

DORAL

INDEMNITY AND HOLD HARMLESS AGREEMENT

Fernando Jimenez (the Property Owner) agree(s) to indemnify and hold harmless The City of Doral and their officers, employees, agents or instrumentalities (the indemnified parties), from any and all claims, liabilities, demands, suits, causes of actions or proceedings of any kind or nature, losses or damages including attorneys' fees and costs of defense, which the indemnified parties may incur arising out of the negligence, error, omission, intentional acts, or other cause arising out of or resulting from the Property Owner's participation in the Doral Facade Improvement Grant Program. The obligation to indemnify and hold harmless specifically includes claims, liabilities, demands, suits, causes of actions or proceedings arising from the negligent acts or omissions of the indemnified parties. The Property Owner shall pay claims and losses in connection with the all of the foregoing and shall investigate and defend all claims, suits, or action of any kind or nature, including appellate proceedings in the name of the applicable indemnified party, and shall pay all costs and judgments and attorney's fees which may issue thereon. The parties agree that this agreement, and its underlying obligations, will be construed under Florida law. The Property Owner further agrees not to contest jurisdiction nor venue in the courts situated in Miami-Dade County, Florida. In consideration of being granted monies for restoration, modifications, signage, or other physical changes to the property located at the above address, the Property Owner is solely responsible for providing contractors, and assuring that contractors are fully insured and licensed and have obtained all necessary permits in accordance with City regulations.

Property Owner agrees that this indemnity and hold harmless agreement is intended to be as broad and inclusive as permitted by the laws of the State of Florida and that if any portion of the agreement is held invalid, it is agreed that the balance shall, notwithstanding, continue in full legal force and effect. Property Owner further states that he/she has carefully read the above indemnity and hold harmless agreement and he/she knows its contents and signs this agreement as his/her own free act. Property Owner's obligations and duties hereunder shall in no manner be limited or restricted by the maintaining of any insurance coverage related to the above referenced event. The undersigned hereby represents and warrants that he/she has full and legal authorization to enter into this agreement.

Dated this 14 day of AUGUST, 2018.

Property Owner
Signature

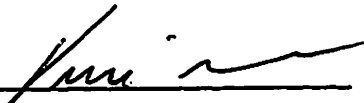

Print Name

FERNANDO JIMENEZ

Witness

NARVA PERA

Print Name

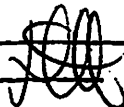



Certification Regarding Lobbying

Certification for Contracts, Grants – Loans, and Cooperative Agreements

The undersigned certifies, to the best of his or her knowledge and belief, that:

1. No Federal appropriated funds have been paid or will be paid, by or on behalf of the undersigned, to any person for influencing or attempting to influence an officer or employee of any agency, a Member of Congress, an officer or employee of Congress, or an employee of a Member of Congress in connection with the awarding of any Federal contract, the making of any Federal grant, the making of any Federal loan, the entering into of any cooperative agreement, and the extension, continuation, renewal, amendment, or modification of any Federal contract* grant, loan, or cooperative agreement.
2. If any, funds other than Federal appropriated funds have been paid or will be paid to any person for influencing or attempting to influence an officer or employee of any agency, a Member of Congress, an officer or employee of Congress, or an employee of a Member of Congress in connection with this Federal Contract, grant loan, or cooperative agreement, the undersigned shall complete and submit standard Form- LLL, "Disclosure Form to Report Lobbying," in accordance with its instructions.
3. The undersigned shall require that the language of this certification be included in the award documents for all sub-awards at all tiers (including sub-contracts, sub-grants, and contracts under grants, loans, and cooperative agreements) and that all sub-recipients shall certify and disclose accordingly.

This certification is a material representation of fact upon which reliance was placed when this transaction was made or entered into. Submission of this certification is prerequisite for making or entering into this transaction imposed by section 1352, title 31, U.S. Code. Any person who fails to file the required certification shall be subject to a civil penalty for no less than \$10,000 and not more than \$100,000 for each such failure.

BY: ALFE HOLDINGS LLC Fernando Jimenez (Print business name & owner's name)

NAME: [Signature] (Signature of owner)

TITLE: MGRM

DATE: 2-14-18

SWORN STATEMENT PURSUANT TO SECTION 287.133 (3) (a)



FLORIDA STATUTES ON PUBLIC ENTITY CRIMES

THIS FORM MUST BE SIGNED AND SWORN TO IN THE PRESENCE OF A NOTARY PUBLIC OR OTHER OFFICIAL AUTHORIZED TO ADMINISTER OATHS

1. This form statement is submitted to Miami-Dade County

by FERNANDO JIMENEZ MONY (Print individual's name and title)

for ALFE HOLDINGS (Print name of business submitting sworn statement)

whose business address is: 3400 NW 78AVE (Address, City, State, Zip Code) Doral, FL 33122

and if applicable its Federal Employer Identification Number (FEIN) is 47-3804463.

If the entity has no FEIN, include the Social Security Number of the individual signing this sworn statement.

2. I understand that a "public entity crime" as defined in paragraph 287.133(1)(g), Florida Statutes, means a violation of any state or federal law by a person with respect to an directly related to the transactions of business with any public entity or with an agency or political subdivision of any other state or with the United States, including, but not limited to any bid or contract for goods or services to be provided to public entity or agency or political subdivision of any other conspiracy, or material misinterpretation.

3. I understand that "convicted" or "conviction" as defined in Paragraph 287.133(1)(b), Florida Statutes, means a finding of guilt or a conviction of a public entity crime, with or without an adjudication of guilt, in an federal or state trial court of record relating to charges brought by indictment or information after July 1, 1989, as a result of a jury verdict, non-jury trial, or entry of a plea of guilty or nolo contendere.

4. I understand that an "Affiliate" as defined in paragraph 287.133(1)(a), Florida Statutes, means:

1. A predecessor or successor of a person convicted of a public entity crime, or
2. An entity under the control of any natural person who is active in the management of the entity and who has been convicted of a public entity crime. The term "affiliate" includes those officers, directors, executives, partners, shareholders, employees, members, and agents who are active in the management of an affiliate. The ownership by one person of shares constituting a controlling interest in another person, or a pooling of equipment or income among persons when not for fair market value under an arm's length agreement, shall be prima facie case that one person controls another person. A person who knowingly enters into a joint venture with a person who has been convicted of a public entity crime Florida during the preceding 36 months shall be considered an affiliate.

5. I understand that a "person" as defined in Paragraph 287.133(1)(e), Florida Statutes, means any natural person or entity organized under the laws of any state or of the United States within the legal power to enter into a binding contract and which bids or applies to bid on contracts of the provision of goods or entity. The term "person" includes those executives, partners, shareholders, employees, members, and agents who are active in management of an entity.



6. Based on information and belief, the statement which I have marked below is true in relation to the entity submitting this sworn statement. (Please indicate which statement applies.)

Neither the entity submitting sworn statement, not any of its officers, director, executives, partners, shareholders, employees, members, or agents who are active in the management of the entity, nor any affiliate of the entity has been charged with and convicted of a public entity crime subsequent to July 1, 1989.

The entity submitting this sworn statement, or one or more of its officers, directors, executives, partners, shareholders, employees, members, or agents who are active in the management of the entity, or any affiliate of the entity had been charged with and convicted of a public entity crime subsequent to July 1, 1989, AND (please indicate which additional statement applies.)

The entity submitting this sworn statement, or one or more of its officers, directors, executives, partners, shareholders, employees, members, or agents who are active in the management of the entity, nor any affiliate of the entity has been charged with and convicted of a public entity crime subsequent proceeding before a Hearing Officer of the State of the State of Florida, Division of Administrative Hearings and the Final Order entered by the Hearing Officer determined that it was not in the public interest to place the entity submitting this sworn statement on the convicted vendor list. Attach a copy of the final order.

I UNDERSTAND THAT THE SUBMISSION OF THIS FORM TO THE CONTRACTING OFFICER FOR THE PUBLIC ENTITY IDENTIFIED I PARAGRAPH 1(ONE) ABOVE IS FOR THAT PUBLIC ENTITY ONLY AND THAT THIS FORM IS VALID THROUGH DECEMBER 31 OR THE CALENDAR YEAR IN WHICH IT IS FILED. I ALSO UNDERSTAND THAT I AM REQUIRED TO INFORM THAT PUBLIC ENTITY PRIOR TO ENTERING INTO A CONTRACT IN EXCESS OF THE THRESHOLD AMOUNT PROVIDED IN SECTION 28.017 FLORIDA STATUTES FOR A CATEGORY TWO OF ANY CHANGE IN THE INFORMATION CONTAINED IN THIS FORM.

[Signature]
(Signature)

Sworn to and subscribed before me this 14 day of AUGUST, 2018.

Personally Known Fernando Jimenez

Or produced identification DL Notary Public-State of Florida

My commission expires (Printed, typed or stamped commissioned name of notary public)

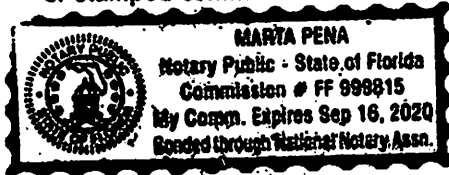

[Signature]



CRIMINAL RECORD AFFIDAVIT

The individual, officer, director, president or entity entering into a contract or receiving funding from the City has _____ has not as of the date of this affidavit been convicted of a felony during the past ten (10) years.

ALFE HOLCOMBS LLC dba KEA ART SPACE
(Printed Name of Business)

3400 NW 78 Ave
(Business Address)

DORAL FL 33122
(City, State, Zip)

FERNANDO SIMENER
(Print Owner or President Name)

STATE OF FLORIDA

COUNTY OF MIAMI

DADE

The a foregoing instrument was acknowledged before me this 14 day of AUGUST 2018, by [Signature] on behalf of ALFE HOLCOMBS LLC ^{c dba} _{Kea art space}
(Signature) (Business Name)
who is personally known to me or has produced DL, as identification

Notary Signature: [Signature]

Type or Print Name: MARTA PEÑA

Notary Seal:





AFFIDAVIT OF FINANCIAL AND CONFLICT OF INTEREST

1. Do you have any past due financial obligations with the City of Doral?

	YES	NO
Single Family House Loans	_____	
Multi-Family Housing Rehab	_____	
CDBG Commercial Loan Project	_____	✓
U.S. HUD Funded Programs	_____	✓
Other (liens, fines, loans, Occupational licenses, etc.)	_____	✓

If YES, please explain:

2. Are you a relative of or do you have any business or financial interest with any elected City of Doral official, Employee, or Member of any Advisory Boards?

YES _____ NO ✓

If yes, please explain:

Any false information provided on this affidavit will be reason for rejection and disqualification of your project-funding request to The City of Doral.

The answers to the foregoing questions are correctly stated to the best of my knowledge and belief.

By FERNANDO JIMENEZ
(Print Name)

Date 8/14/18

SUBSCRIBED AND SWORN TO (or affirmed) before me this 14 day of AUGUST 2018

By [Signature] He/She is personally known to me or has presented
(Signature)

DLJ552240721700 as Identification.
(Type of Identification)

[Signature]
(Signature of Notary)

(Print or Stamp of Notary)

FF999815
(Serial Number)

9-16-2020
(Expiration Date)

Notary Public - Stamp of FLORIDA
(State)

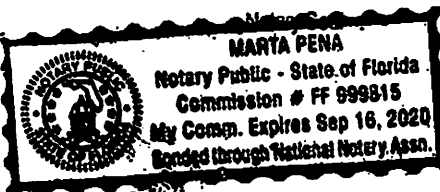

Florida

DRIVER LICENSE

USA



9 CLASS E

1 JIMENEZ
2 FERNANDO

8 140 MERIDIAN AVE UNIT 341
MIAMI, FL 33139

3 DOB 05/10/1972 15SEX M

4C EXP 05/10/2026 16HGT 6'-03"

12 REST NONE 9a END A

SAFE DRIVER

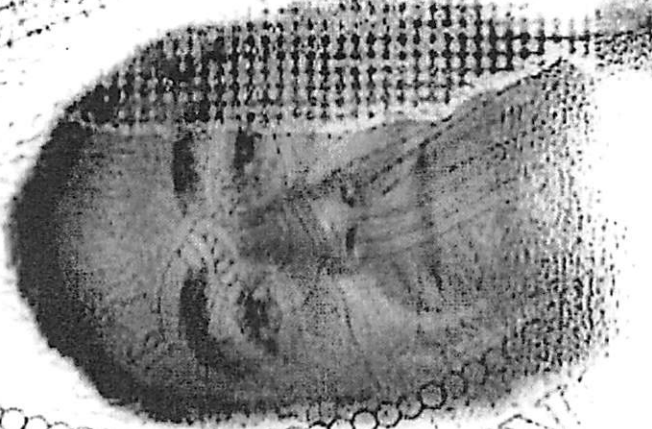

07/2018

9206070021

DONOR

Operation of a motor vehicle constitutes consent to any sobriety test required by law.

**Electronic Articles of Organization
For
Florida Limited Liability Company**

**L15000066473
FILED 8:00 AM
April 15, 2015
Sec. Of State
jshivers**

Article I

The name of the Limited Liability Company is:

ALFE HOLDINGS LLC

Article II

The street address of the principal office of the Limited Liability Company is:

**3287 NW 78 AVE.
MIAMI, FL. 33122**

The mailing address of the Limited Liability Company is:

**3287 NW 78 AVE.
MIAMI, FL. 33122**

Article III

The name and Florida street address of the registered agent is:

**FERNANDO JIMENEZ
3287 NW 78 AVE.
MIAMI, FL. 33122**

Having been named as registered agent and to accept service of process for the above stated limited liability company at the place designated in this certificate, I hereby accept the appointment as registered agent and agree to act in this capacity. I further agree to comply with the provisions of all statutes relating to the proper and complete performance of my duties, and I am familiar with and accept the obligations of my position as registered agent.

Registered Agent Signature: **FERNANDO JIMENEZ**

Article IV

The name and address of person(s) authorized to manage LLC:

Title: MGR
FERNANDO JIMENEZ
3287 NW 78 AVE.
MIAMI, FL. 33122

L1500066473
FILED 8:00 AM
April 15, 2015
Sec. Of State
jshivers

Signature of member or an authorized representative

Electronic Signature: FERNANDO JIMENEZ

I am the member or authorized representative submitting these Articles of Organization and affirm that the facts stated herein are true. I am aware that false information submitted in a document to the Department of State constitutes a third degree felony as provided for in s.817.155, F.S. I understand the requirement to file an annual report between January 1st and May 1st in the calendar year following formation of the LLC and every year thereafter to maintain "active" status.

2018 FLORIDA LIMITED LIABILITY COMPANY ANNUAL REPORT

DOCUMENT# L15000066473

Entity Name: ALFE HOLDINGS LLC

Current Principal Place of Business:

3287 NW 78 AVE.
MIAMI, FL 33122

Current Mailing Address:

3287 NW 78 AVE.
MIAMI, FL 33122

FEI Number: 47-3804463

Certificate of Status Desired: No

Name and Address of Current Registered Agent:

JIMENEZ, FERNANDO
3287 NW 78 AVE.
MIAMI, FL 33122 US

The above named entity submits this statement for the purpose of changing its registered office or registered agent, or both, in the State of Florida.

SIGNATURE:

Electronic Signature of Registered Agent

Date

Authorized Person(s) Detail :

Title MGR
Name JIMENEZ, FERNANDO
Address 3287 NW 78 AVE.
City-State-Zip: MIAMI FL 33122

I hereby certify that the information indicated on this report or supplemental report is true and accurate and that my electronic signature shall have the same legal effect as if made under oath; that I am a managing member or manager of the limited liability company or the receiver or trustee empowered to execute this report as required by Chapter 605, Florida Statutes; and that my name appears above, or on an attachment with all other like empowered.

SIGNATURE: FERNANDO JIMENEZ

MGR

03/20/2018

Electronic Signature of Signing Authorized Person(s) Detail

Date

Miami-Dade Water and Sewer Department
P O Box 026055
Miami, FL 33102-6055

Name: **ALFE HOLDINGS LLC**
Account Number: 1501408157
Billing Date: 04/16/2018
Past Due Date: 05/07/2018

Billing Inquiries (hours 8:00 AM - 7:00 PM) 305-665-7477
Report any hazardous conditions to 305-274-9272
Water Conservation Program Information- Call 311

Messages

Go green by enrolling in Paperless Billing and/or Auto Pay. Pay your bill and view your account on-line at www.miamidade.gov/water. To pay by phone using your bank account, call 1-800-565-1800. To use a credit card call 1-800-510-0880.

On 4/28 DISPOSE OF UNWANTED MEDICATIONS
WWW.MIAMIDADE.GOV/POLICE

Account Summary

Previous Balance \$ 863.92
Payment Received -918.92
Current Charges 893.50
Additional Fees 55.00
Total Account Balance \$ 893.50

Unpaid Balance -55.00

Service From	Service To	Meter Number	Days of Service	Prior Reading	Current Reading	Consumption in CCF	Consumption in Gallons
01/08/18	04/09/18	14226244	91	655	752	97	72556

Service Address: 3400 NW 78TH AVE



Water Charges

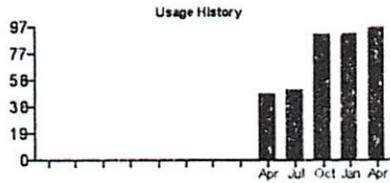

Water Charges 450.09
Hydrant Charge 2.40
Water Charges Subtotal \$ 452.49

Additional Fees
CONP Field Visit Charge \$ 20.00
Reconnect Charge Fee \$ 35.00

04 - 23.2018

For more information see back of bill
Return this portion with Payment
Miami-Dade Water and Sewer Department
P O Box 026055
Miami, Fl. 33102-6055

Account Number	Past Due Date	Amount Due (US \$)	Amount Enclosed
1501408157	05/07/2018	\$ 893.50	Thank you for your prompt payment

- Payment in US funds must be received by the past due date to avoid discontinuance of service. A 10% late charge will be assessed if payment is not received by the past due date
- Check box for address change. Please print changes on reverse side.
- Pay by phone or Online:
1-800-565-1800 checking/savings
1-800-510-0880 credit card www.miamidade.gov/water

ALFE HOLDINGS LLC
3281 NW 78TH AVE
DORAL FL 33122-1121



**Miami-Dade Water and Sewer Department
P O Box 026055
Miami, FL 33102-6055**

Name: ALFE HOLDINGS LLC
Account Number: 1501408157
Billing Date: 04/16/2018
Past Due Date: 05/07/2018

Billing Inquiries (hours 8:00 AM - 7:00 PM) 305-665-7477
Report any hazardous conditions to 305-274-9272
Water Conservation Program Information- Call 311

Water Fees and Taxes
Meter Number: 14226244

Excise Tax	45.01
Utility Service Fee	27.00
Water Fees and Taxes Subtotal	\$ 72.01

Stormwater
For information Call: 305-593-6740

Stormwater Charge	369.00
Stormwater Subtotal	\$ 369.00

Description of Billing Terms

- DEPOSIT REFUND/CREDIT** - Retail customers with a good credit history will have their deposit credited to their account. Good credit history is defined as a period of two (2) years with no service interruptions combined with a record of less than three (3) late payments for a quarterly customer or less than five (5) late payments (for a monthly customer). Retail customers closing their accounts will be refunded their deposit, less any amount still due.
- Consumption CCF (hundred cubic feet)** - The department bills in hundred cubic feet which is expressed as CCF. One CCF is equivalent to 748 gallons. (For example: 10 CCF x 748 gallons = 7,480 gallons)
- UTILITY SERVICE FEE** - All water and sewer utilities in Miami-Dade County are required to pay this fee to support regulatory activities of the Permitting, Regulatory and Economic Resources Department.
- HYDRANT CHARGE** - A charge to the customer for the hydrant water service and for the installation, maintenance and repair of the hydrants. Customers in the unincorporated areas of Miami-Dade County and certain municipalities are billed this charge if their property is located within a radius of 860 feet of an existing fire hydrant, as per Miami-Dade County Code.
- EXCISE TAX & STORMWATER CHARGE** - This is a charge imposed by Unincorporated Miami-Dade County or certain municipalities. It is collected and remitted to either Miami-Dade County or the appropriate municipality.

AREA OFFICES

For payment of bills and requests for application for water and sewer service.

3575 South LeJeune Road
HOURS: 8:00 A.M. - 4:30 P.M.
(Cashiers Only)

10710 S.W. 211th Street
HOURS: 8:00 A.M. - 4:30 P.M.
(South Dade Government Center)

2525 N.W. 62nd Street
HOURS: 8:00 A.M. - 4:30 P.M.
(Martin Luther King Plaza)

3071 S.W. 38th Avenue
HOURS: 8:00 A.M. - 4:30 P.M.
(Douglas Road Metrorail Station)

CONNECT WITH US



miamidadewater

To change your mailing address, please visit www.miamidade.gov or complete the form below and return with your payment

Name: _____ Home Phone # _____
Street Address: _____ Work Phone # _____
City: _____ State: _____ Zip: _____
E-mail Address: _____ @ _____

150092605423



[Previous on List](#) [Next on List](#) [Return to List](#)

Fictitious Name Search

No Filing History

Fictitious Name Detail

Fictitious Name

KER ART SPACE

Filing Information

Registration Number G18000089730
Status ACTIVE
Filed Date 08/13/2018
Expiration Date 12/31/2023
Current Owners 1
County MULTIPLE
Total Pages 1
Events Filed NONE
FEI/EIN Number NONE

Mailing Address

3287 NW 78 AVE
MIAMI, FL 33122

Owner Information

ALFE HOLDINGS LLC
3281 NW 78TH AVE
DORAL, FL 33122
FEI/EIN Number: 47-3804463
Document Number: L15000066473

Document Images

08/13/2018 -- Fictitious Name Filing

[Previous on List](#) [Next on List](#) [Return to List](#)

Fictitious Name Search

No Filing History



Go paperless. Sign up for paperless billing and we'll send you an email reminder to pay. It's easier, safer, and more convenient.

Easily manage your account with myAT&T. You can pay your bill online, sign up for paperless billing and AutoPay, and manage your account. Go to att.com/myatt to get started.

Total due
\$77.00
 Autopay is scheduled for:
 Aug 01, 2018

Account summary

Your last bill	\$77.00
Payment, Jul 02 - Thank you!	-\$77.00
Remaining balance	\$0.00

Service summary

 Internet	\$77.00
<i>Page 2</i>	
Total services	\$77.00

Total due **\$77.00**

Autopay is scheduled to debit your bank account on Aug 01, 2018

2370.8.370.77135 1 AV 0.378 rc



ALFE HOLDING LLC
 DBA DORAL DEKOR CENTER
 3281 NW 78TH AVE
 DORAL FL 33122-1121

Service activity **Internet****Monthly charges***Jul 12 - Aug 11*

1. Internet Basic 6 <i>(Promotional Offer)</i>	\$50.00
2. Static IP 8	\$15.00
3. Internet Equipment Fee	\$10.00

Surcharges & fees

4. Cost Assessment Charge	\$1.30
---------------------------	--------

Government taxes & fees

5. FL County Sales Tax	\$0.10
6. FL State Sales Tax	\$0.60

Total for Internet**\$77.00****Important information****Late payment charge**

A late payment charge of \$9.25 will be assessed if payment is not received on or before the due date.

Electronic check conversion

Paying by check authorizes AT&T to use the information from your check to make a one-time electronic fund transfer from your account. Funds may be withdrawn from your account as soon as your payment is received. If we cannot process the transaction electronically, you authorize AT&T to present an image copy of your check for payment. Your original check will be destroyed once processed. If your check is returned unpaid you agree to pay such fees as identified in the terms and conditions of your agreement, up to \$30. Returned checks may be presented electronically. If you want to save time and stamps, sign up for AutoPay at att.com/autopay using your checking account. It's easy, secure, and convenient!

How to read your bill

See att.com/bill for information on how to read your bill.

AT&T U-verseSM TV, AT&T Internet and AT&T Phone provided by AT&T Florida.

© 2018 AT&T Intellectual Property. All rights reserved.



ARK DEVELOPMENT GROUP INC.
GENERAL CONTRACTORS - CONSTRUCTION MANAGEMENT
LICENSE CGC1505424



8/17/ 2018

Proposal for Exterior Façade
KER ART SPACE
3400 NW 78TH AV
DORAL, FL 33122

SCOPE OF WORK:

Ark Development group will provide all materials, supervision, labor, tools and equipment necessary to complete THE EXTERIOR MODIFICATIONS of the above referenced building.

SCOPE OF WORK

1-Work to be done based on Architectural drawings and designs by "The Goris Group Corp"
Dated 8/14/2018.

2- Demo: as per plans.

3- Provide ADA Ramps, railings, pathways, exterior walls, lighting, stairs, sidewalks, store front windows
Frame all walls, provide electrical outlets install insulation, install drywall.

all detailed work to be done as per plans

4-PRICE: Total price for materials and labor is \$117,000.00 One Hundred Seventeen Thousand Dollars
and 00 cts.

- After signing \$20,000.00
- Rest on Weekly draws to be mutually arranged according to progress.

ARK DEVELOPMENT GROUP INC.
GENERAL CONTRACTORS - CONSTRUCTION MANAGEMENT
LICENSE CGC1505424



5- Effective Date and Signature

This contract shall become effective on the date it is signed by both parties.

We, the undersigned, have read understood, and agree to each of the provisions of this contract and hereby acknowledge receipt of a copy of this contract.

By: Randolph Amaya on behalf of _____
ARK Development Group, Inc.

Title: President Date: 8/17/2018

By: _____ Date: _____
Owner

Title _____ Date: _____

Exemption:
Permit fees, engineering/professional services for plans, permits by other, owner understand that any previous work done not inspected is not responsibility of Ark Development, as per owner instructions we will complete all outlined work and proceed, and owner will take care of inspections when all work is complete, Ark will cooperate and assist owner to comply to get final inspections.



**SAE | SOUTHERN ASPHALT
ENGINEERING, INC.**

Your Partners in Asphalt Restoration & Maintenance.

1430 NW 108th Ave. Suite 200 Miami, FL. 33172
Ph: 305-667-8390 / Fax: 305-667-0396
Licensed & Insured Dade E981900 Broward 06-3B-12901X
www.southernasphaltengineering.com

Proposal/Contract

Date 8/16/2018 Proposal # 20181056

Customer:

Ker Art Space
C/O Fernando Jimenez
3400 NW 78th Ave.
Doral, Fl. 33122

Job Name:

Facade Renovations

Phone # 305-477-0096 Fax #

Email: fjimenez@Kertiles.com

We hereby submit specifications to furnish labor material & equipment for the following work as requested:

Fernando,

This proposal is for the facade renovations encompassing the 4 Concrete Entrance Stairways, Accesible Ramps and the architectural handrails and pedestrian walkways leading from the sidewalk to Staircases.

- 1-Provide Elevation and Grade Stakes for construction of Stairways and Accesible Ramps
- 2-Forming and Pouring of Concrte Foundations, Landing and Steps Walkways and Curb and Gutters
- 3-Construction and Installation of Architectural Steel Railings conforming to dimensions as provided on site plans.

Price includes minimal regrading and re-sodding of disturbed areas

No Sales Agent, or any other Employee of SAE Inc. , customer or customer representative shall have the authority to waive or modify any terms and conditions of this agreement nor deviate from the specifications and terms set herein proposal. No verbal representations expressed or implied can be relied on and will not supersede the terms and conditions of the written specifications set forth.

Any change, alteration, or deviation from the specifications as set forth in the proposal, which involve additional charge or cost, will only be permitted upon written confirmation via Change Order which will be completed at an additional cost and payable upon execution thereof.

WITH PAYMENTS TO BE MADE AS FOLLOWS: 100% upon completion. TOTAL \$195,500.00

Permit and procurement fees are not included, additional work required by such permit may be an additional charge aside from contract price. Permit Cost are due upon receiving Invoice for Permit Fees and Expediting Services of issued permits. Permit Costs and Fees are due immediately upon receipt.

Owner or Association management will provide 2 copies of site plans for permitting purposes. Provided surveys or site plans are to be up to date and matching existing conditions of pavement area.

NOTE: This Proposal may be withdrawn by us if not accepted within 30 Days.

The above price, specifications and conditions are satisfactory and are hereby accepted. You are authorized to do the work as specified. Payment will be made as outlined above. A monthly service charge of 1-1/2% will be added if payment is not received under the terms of the contract.

Respectfully Submitted: Jose Franco / President

Accepted by _____
Name Signature Title Date

PLEASE EMAIL ACCEPTED PROPOSAL TO INFO@SOUTHERNASPHALTENGINEERING.COM OR FAX TO (305) 667-0396

In any dispute, associated with this agreement between the client and Southern Asphalt Engineering, the prevailing party shall be entitled to reasonable attorney's fees and costs. Venue shall be Dade County, Florida.

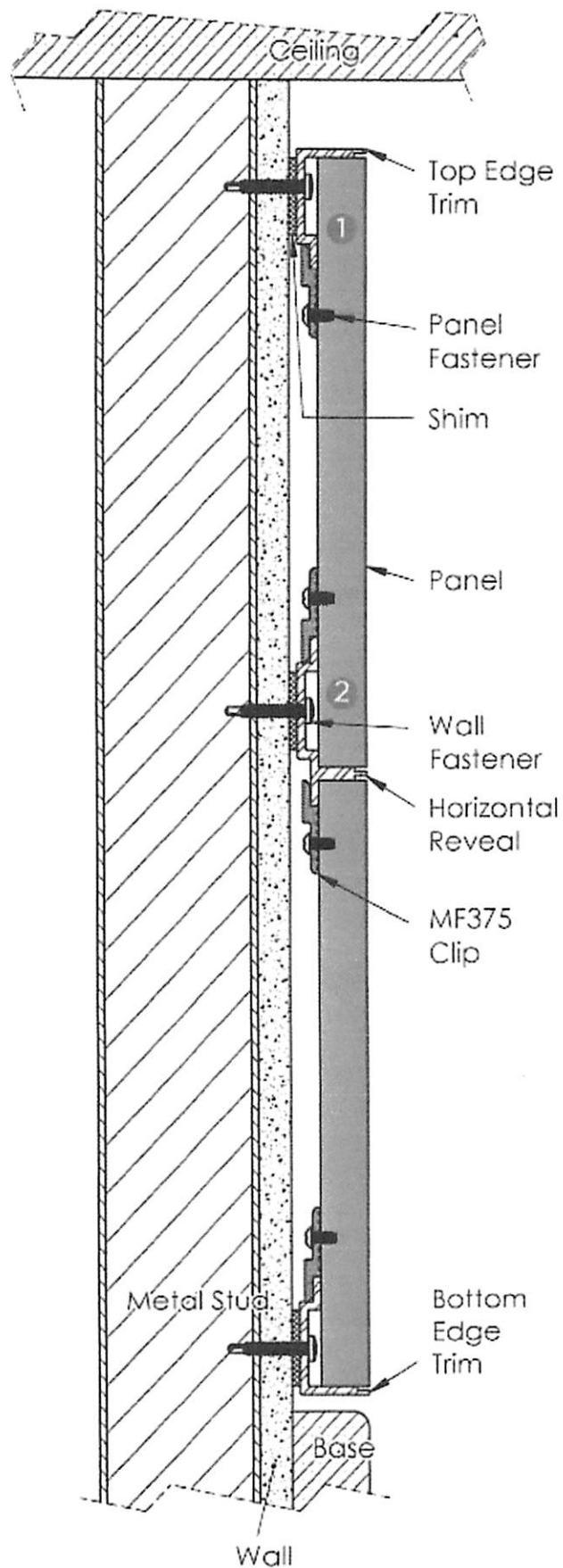

PATENT PENDING

- Ships from stock
- Anodized in clear, black and custom colors

1 Fast & simple installation centered around the intuitive Monarch Z Clip System

2 Horizontal Reveals & Edge Trim to be punched with slotted holes for adjusting into place after mounting.

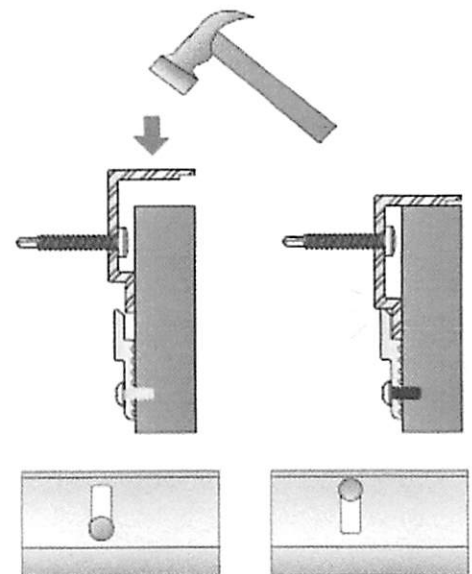

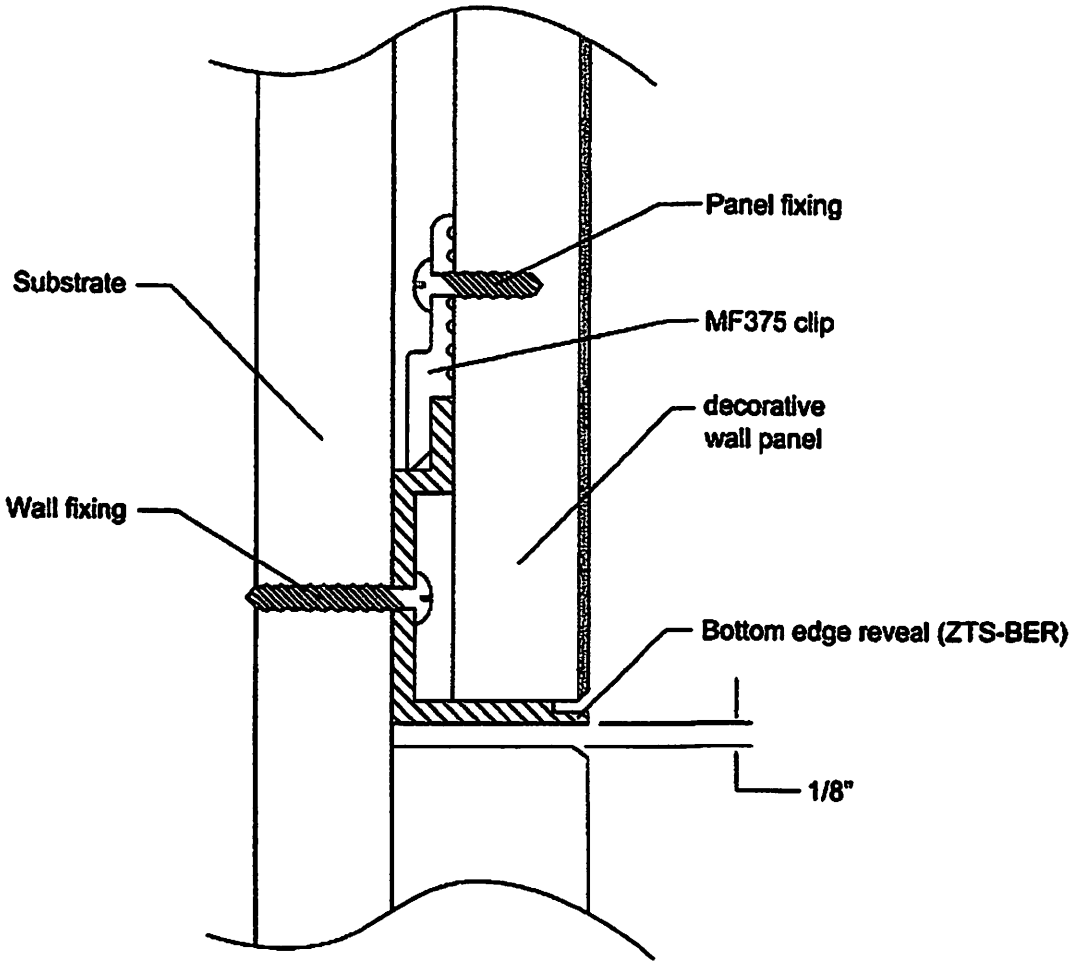



5731 NW 55th Lane
 Tamarac, FL 33319
 Cel: 561-213-9735
 E-mail: alterss@outlook.com

Estimate

DATE August 17, 2018
Estimate # 14

Bill To:

KER ART SPACE
 3400 NW 78th Ave., Doral, FL 33122
 Phone:
 E-mail:

Prepared by: Vincent Mansour
Cel: 561-506-3900
E-mail: alterss@outlook.com

Job Description:

Exterior Work

Location of Job:

3400 NW 78th Ave., Doral, FL 33122

Comments or special instructions:

This estimate covers the renovation of the fascade. Alter Simple Solutions Inc. will furnish all the materials necessary, labor, equipment rental, tools, etc. to complete all modification. Scope of work is based on the Architectural drawing provided.

Description	AMOUNT
Work: Installation of exterior Pre-fabricated Paneling system	\$ 102,000.00
◆ All demolition needed	
◆ Installation of pre-fabricated clip-on exterior paneling system as per manufacturer's installation specifications or NOA	
◆ Exterior paint	
TOTAL	\$ 102,000.00

**Change of order will be billed separately according to the work added.
 We appreciate your Business!**



Design Solution of South Florida, Inc.

www.dssflorida.com

Construction Division

August 17, 2018

Ker Art Space – Exterior Proposal

3400 N.W. 78th Avenue,
Doral, FL 33122

Re: Project Number: DSSFL (18) 203

Dear Fernando,

As requested, Design Solution of South Florida, Inc. is pleased to provide you with the following proposal for the façade renovations entailing the construction preparation for the installation of the prefabricated panel system on a clip system. This is based on the architectural plans provided by Design Solution of South Florida. This is also based on owner's requirements and directions while compliant with city codes and regulations.

Scope of Services:

Installation of prefabricated wall panel system and paint throughout the entire 34,000 s.f. building:

- 1.) Equipment rental
- 2.) Painting for entire warehouse
- 3.) Complete project management from start to finish
- 4.) Demolition and site work as needed for preparation of installation of panel system
- 5.) Installation of prefabricated wall panel system on a clip system.

Architectural plans as provided by Design Solution of South Florida, Inc. Any deviation of the plans shall notify the architect, contractor or engineer of record. Any change order shall be notified to the owner as soon as possible. No verbal representation shall supercede the drawings permitted by the city and interpreted by the city.

Any change, alteration, or deviation from the specifications as set forth in the proposal, which involve additional charge or cost, will only be permitted upon written confirmation via Change Order which will be completed at an additional cost and payable upon execution thereof.

WITH PAYMENTS TO BE MADE AS FOLLOWS: 100% upon completion. TOTAL \$93,000.00

Design • Construction Management • Planning

1243 FAIRLAKE TRACE - # 1203, WESTON, FL 33326
TEL (954) 200-2255 www.dssflorida.com



Design Solution of South Florida, Inc.

www.dssflorida.com

Construction Division

Exclusions:

- 1.) Permit and procurement fees are not included.
- 2.) Additional work with unforeseen complications arising from construction.

NOTE: The proposal is valid 30 Days within received by client.

If the proposal is acceptable with the specifications and plans provided and the conditions are satisfactory, then a payment of 20% is due upon initial agreement of the signing of this proposal. Billing will be done monthly here then after. Any delay is subject to penalties and fees.

Best regards,

Hector Ampuero, President

If payment by check, please make payable to:

Design Solution of South Florida, Inc.

Mailing address:

1243 Fairlake Trace, # 1203

Weston, FL 33326

Sincerely,

Design Solution of South Florida, Inc.

Hector Ampuero, Assoc. AIA, NCARB

Project Manager-Design Consultant

hector@dssflorida.com

Agreed as to scope of services and fees proposed:

Name: _____

Signature: _____

Date: _____

Design • Construction Management • Planning

1243 FAIRLAKE TRACE - # 1203, WESTON, FL 33326
TEL (954) 200-2255 www.dssflorida.com

KER ART SPACE - F.

3400 N.W. 78th AVENUE,
Doral, Florida

DRAWING INDEX	CODE RESEARCH	
<p>A-00 GENERAL NOTES A-01 EXISTING OVERALL SURVEY PLAN A-02 EXISTING ELEVATION & PLAN A-03 PROPOSED ELEVATIONS AND 3-D VIEW A-04 CURRENT PICTURES A-05 PROPOSED RENDERINGS</p>	<p>GOVERNING CODE</p> <p>BUILDING HEIGHT</p> <p>PROJECT AREA</p> <p>TYPE OF CONSTRUCTION</p> <p>LEVEL OF ALTERATION</p> <p>MAXIMUM TRAVEL DISTANCE</p> <p>OCCUPANCY CLASSIFICATION</p> <p>FOLIO #:</p> <p>LEGAL DESCRIPTION</p>	<p>2017 Florida Building Code, 6th Ed., Existing Florida Building Code, 2014 Accessibility Code, Florida Fire Prev Fifth Edition.</p> <p>24'-8" Approximately</p> <p>39,000 S.F.</p> <p>Type III</p> <p>2</p> <p>200</p> <p>S-2 / M</p> <p>30-3027-007-0011</p> <p>CRUDELE AIRPORT INDUSTRIAL F 86-29 E352FT OF S235FT OF TRAC</p>

TRACT "A"
CRUDELE AIRPORT INDUSTRIAL
(P.B. 86, PG. 29)
N88°31'27"E 352.00'

EXIST. CONC.
BASE (TYP.)

GREEN AREA

GREEN AREA

CONC.
PLATFORM

METAL
RAMP

CONC.
RAMP

WALK

POINT

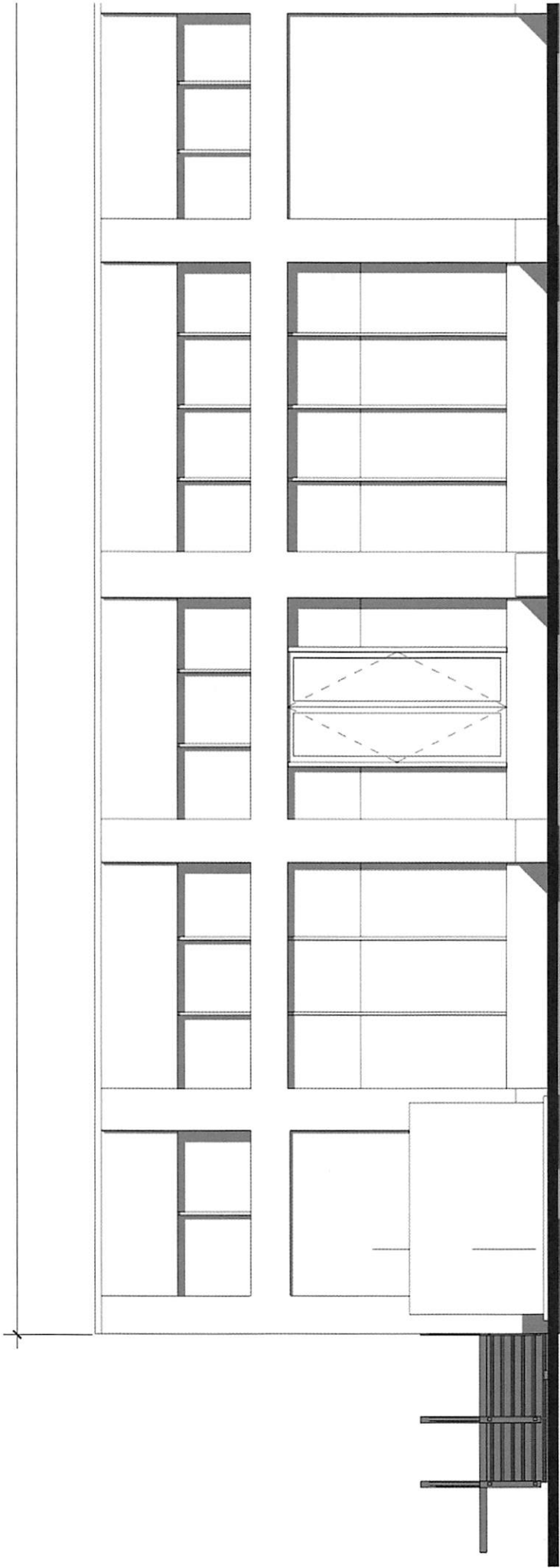

EXISTING NORTH SIDE (FRONT)
ELEVATION

1 1/8" = 1'-0"

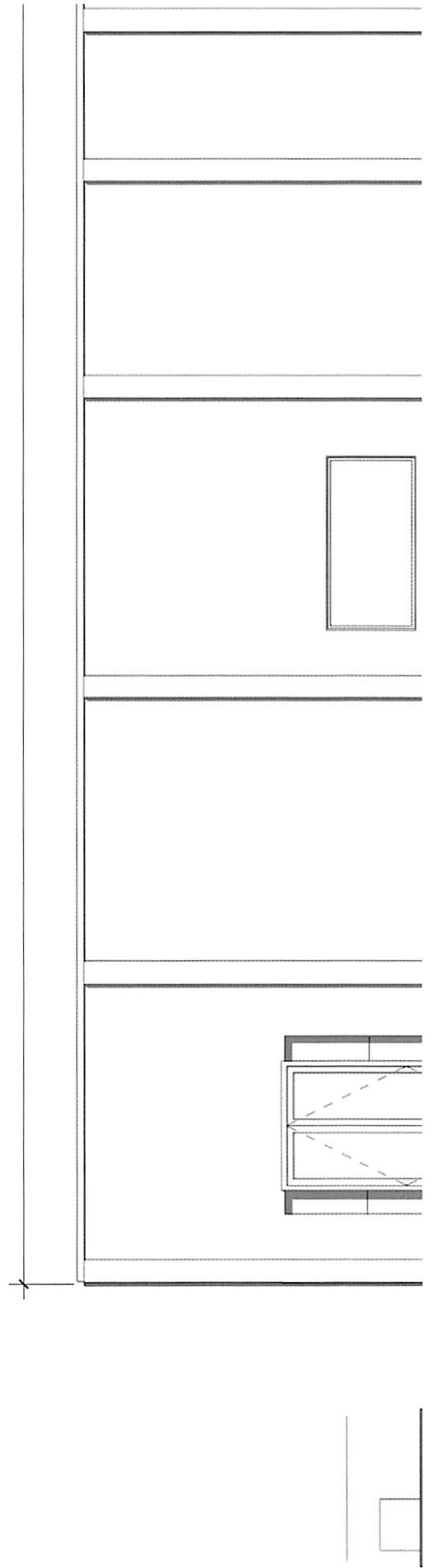

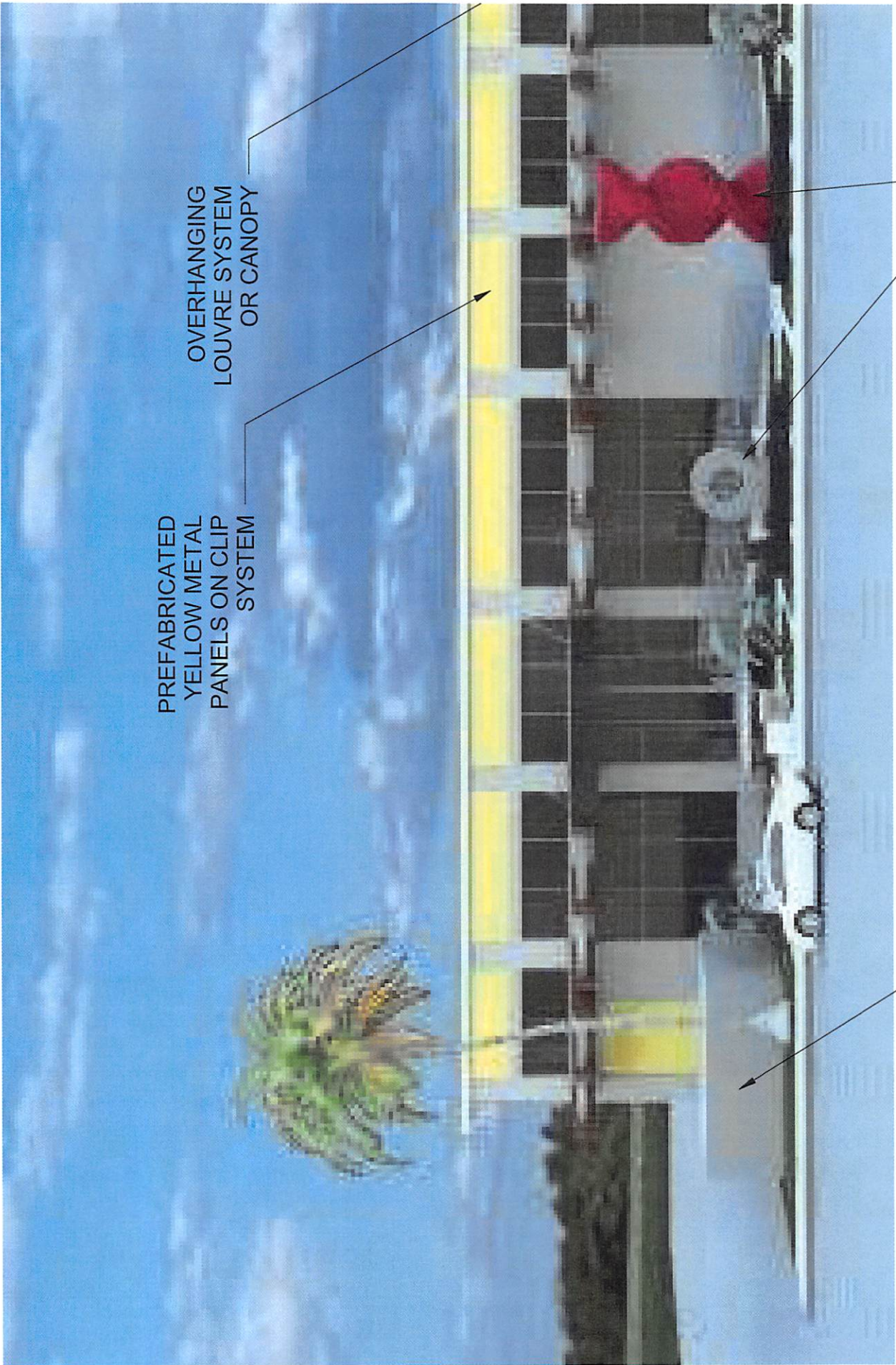

PREFABRICATED
YELLOW METAL
PANELS ON CLIP
SYSTEM

OVERHANGING
LOUVRE SYSTEM
OR CANOPY

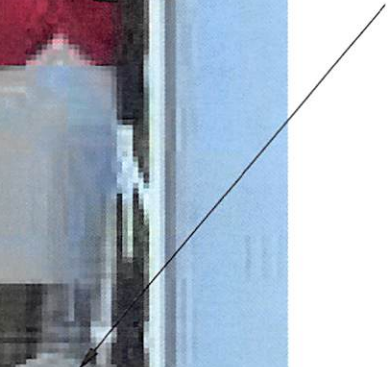
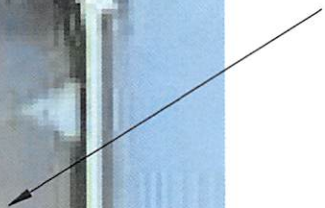





RESOLUTION No. 18-166

A RESOLUTION OF THE MAYOR AND THE CITY COUNCIL OF THE CITY OF DORAL, FLORIDA, APPROVING THE AWARD OF FISCAL YEAR 2018 FAÇADE IMPROVEMENT GRANTS IN THE AMOUNT OF \$10,000.00 TO DORAL HOME DÉCOR CENTER DBA CASA LINDA; \$10,000.00 TO ALFE HOLDINGS LLC DBA KER ART SPACE; AND \$10,000.00 TO THE VILLAS OF AMBERWOOD CONDOMINIUM ASSOCIATION INC., PROVIDING FOR IMPLEMENTATION; AND PROVIDING FOR AN EFFECTIVE DATE

WHEREAS, the City of Doral (the "City") provides financial assistance to businesses and commercial property owners in Doral through the Façade Improvement Grant in order to stimulate private sector investment, economic growth and the beautification of buildings within Doral; and

WHEREAS, the City received ten (10) applications in response to the FY 2018 Cycle of the Façade Improvement Grant; and

WHEREAS, after careful review of the applications, the Façade Improvement Grant Scoring Committee respectfully recommends that the Mayor and City Council approves Façade Improvement Grant awards to each of the following organizations:

1. Doral Home Décor Center LLC dba Casa Linda - \$10,000.00
2. Alfe Holdings LLC dba KER Art Space - \$10,000.00
3. Villas of Amberwood Condominium Association - \$10,000.00

NOW, THEREFORE, BE IT RESOLVED BY THE MAYOR AND CITY COUNCIL OF THE CITY OF DORAL, FLORIDA, AS FOLLOWS:

Section 1. Recitals. The foregoing recitals are confirmed, adopted, and incorporated herein and made a part hereof by this reference.

Section 2. Grant Approval. The award of the Façade Improvement Grant is hereby approved in the following amounts to the following businesses:

\$10,000.00 to Doral Home Décor Center LLC dba Casa Linda;

\$10,000.00 to Alfe Holdings LLC dba KER Art Space; and

\$10,000.00 to The Villas of Amberwood Condominium Association.

Section 3. Implementation. The City Manager, City Attorney, and City Clerk are hereby authorized to take such further action as may be necessary to implement the purpose and provisions of this Resolution.

Section 4. Effective Date. This Resolution shall become effective immediately upon its adoption.

The foregoing Resolution was offered by Vice Mayor Rodriguez who moved its adoption.
The motion was seconded by Councilmember Mariaca and upon being put to a vote, the
vote was as follows:

Mayor Juan Carlos Bermudez	Yes
Vice Mayor Ana Maria Rodriguez	Yes
Councilman Pete Cabrera	Absent/Excused
Councilwoman Christi Fraga	Yes
Councilwoman Claudia Mariaca	Yes

PASSED AND ADOPTED this 12 day of September, 2018.



JUAN CARLOS BERMUDEZ, MAYOR

ATTEST:



CONNIE DIAZ, CMC
CITY CLERK

APPROVED AS TO FORM AND LEGAL SUFFICIENCY
FOR THE USE AND RELIANCE OF THE CITY OF DORAL ONLY:



WEISS, SEROTA, HELFMAN, COLE & BIERSMAN, P.L.
CITY ATTORNEY